

PRELIMINARY - MAGNETIC CANopen ABSOLUTE MULTI TURN MODULAR SENSORS, TCW4 RANGE

- With its modular design, the TCW4 CANopen absolute multi-turn sensor offers maximum flexibility when installing it.
- Application fields : agriculture, construction, forestry vehicles, medical, solar panels...
- Robustness and excellent resistance to shocks / vibrations.
- Standard IP 67 protection (IP69K option).
- Operating temperature range: -20°C to 85°C.
- Magnetic technology.
- Universal supply 5 to 30Vdc – CANopen interface.
- Available resolution up to 12 bits per revolution.
- Turn counting up to 16 bits.
- Also available : analog, PWM and SSI outputs.
- Standard cable output with SUBD9 connector.

CANopen®

CiA®

DS 301 V4.02

DS 406 V3.1

STANDARD TCW4 DIMENSION

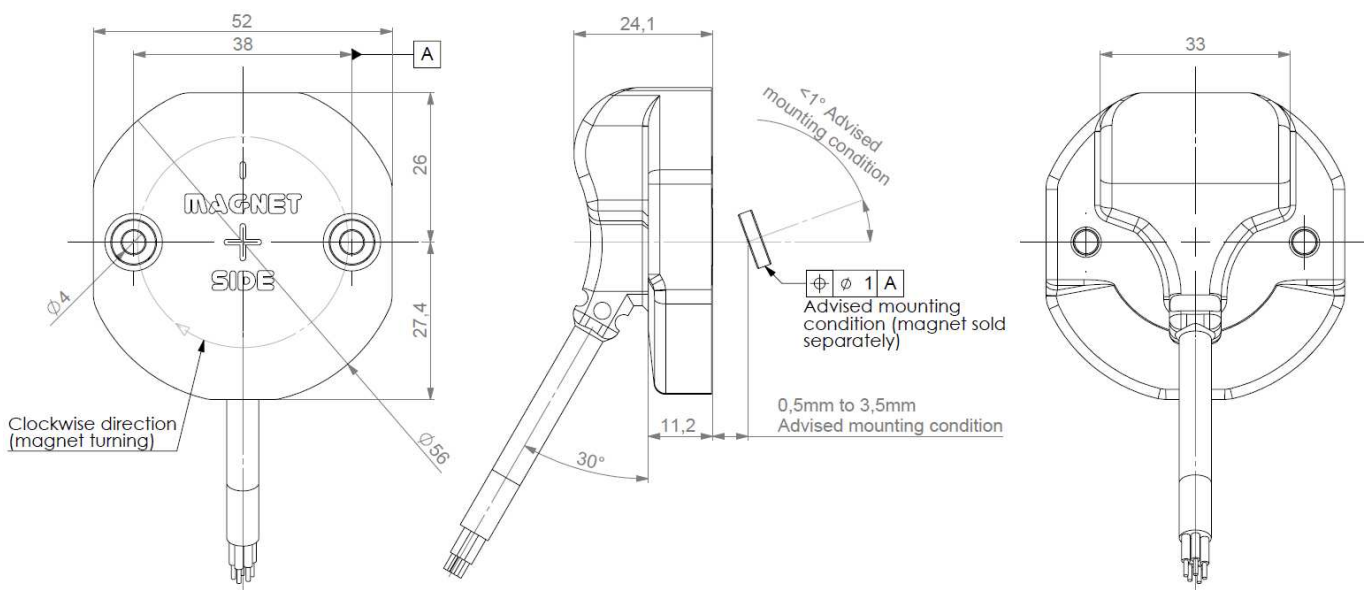

Advised mechanical working conditions (for optimal performances) :

- recommended air gap: 0,5mm to 3mm (between magnet's and sensor's faces),
- recommended parallelism : $\pm 1^\circ$ (between magnet and sensor),
- Misalignment tolerance : $\pm 0,5$ mm (between magnet's and sensor's centers).

Shaft system with magnet to be ordered separately (cf specific data-sheet M9105).

MECHANICAL DATA

Material	Macromelt OM638	Protection	IP 67
Encoder weight (approx.)	0,150 kg	Shocks (EN60068-2-27)	$\leq 2000\text{m.s}^{-2}$ (during 6 ms)
Operating temperature	- 20... + 85 °C (encoder T°)	Vibrations (EN60068-2-6)	$\leq 200\text{m.s}^{-2}$ (55 ... 2 000 Hz)
Storage temperature	- 20... + 85 °C		

ADAPTATION POSSIBILITY

BEI Sensors distinguishes itself by its flexible approach and ability to react to customers needs, with us no limit exists; we shall always try to supply you the product offering the best solution to your specifications.

Modified mechanics: Precision prototypes units, small and medium size. Units that will match themselves exactly to your mechanical configuration or to your dimensional constraints.

Specific shaft system: for example with integrated coupling.

Send us your subset: we can integrate our encoder into your subset and return you the complete assembly with the guarantee of an optimal mounting.

Connection / Cable assemblies: On the whole range of our sensors a wide selection of electrical connections are possible.

ELECTRICAL DATA

Power supply	5-30Vdc	Sampling rate*	1 kHz
Consumption without load	< 40mA (at 24Vdc)	Accuracy	± 0.3 %
Resolution in the turn	12 bits	Repeatability	± 0.1 %
Number of turns	16 bits max.	Introduction	< 1s
Total resolution	Up to 28 bits	Refresh rate	< 400µs

* Nota : Internal data refresh rate

PROGRAMMABLE PARAMETERS

Resolution: defines the resolution per revolution (0 à 4 096).

Transmission speed : programmable from 10kBaud (1 000m) to 1 Mbaud (25 m) ; value per default : 20 Kbaud.

Address : defines the software address of the encoder on the bus (1 à 127, Value per default : id = 1).

Direction : defines the direction of count of the encoder.

RAX : define the value of the current position (stationary shaft).

Comes : high and low limits.

COMMUNICATION MODES

Encoder configuration : Reading/Writing of the encoder objects dictionary (SDO mode).

3 modes are available to interrogate the encoder position/speed :

CYCLIC mode : the encoder transmits its position in an asynchronous manner. The frequency of the transmission is defined by the programmable cyclic timer register from 0 to 65 535 ms,

SYNCHRO mode : the encoder transmits its position on a synchronous demand by the master.

POOLING mode (Answer to a RTR signal) : the encoder only answers to a request.

CANOPEN CONNECTION, CABLE + DB9 CONNECTOR

		N.C.	CAN LOW	CAN GND / 0V	N.C.	N.C.	0V	CAN HIGH	N.C.	5/30Vdc	Ground
BB	PVC Cable + DB9	1	2	3	4	5	6	7	8	9	General shielding

Nota : Refer to the bus standards for the maximal derivation length.

TCW4 ORDERING REFERENCE (Contact the factory for special versions , ex : dimensions, connections...)

	Mechanics	Supply	Output stage	Code	Resolution	Connection	Orientation
TCW4 :	00 :	P :	BB :	B :	12B16 :	BB :	R005 :
Magnetic Absolute multi-turn encoder	modular	5 to 30Vdc	CANopen	Binary	12 x 16 bits	PVC Cable + DB9 CANopen	Radial 0.5m cable with SUBD9
Ex: TCW4_	00 //	P	BB	B //	12B16 //	BB	R005

Made in France