

PARALLEL ABSOLUTE MULTITURN ENCODER - PUSH PULL - PHM5 RANGE

- Solid shaft $\varnothing 6$ and $\varnothing 10$ mm,
- Robustness and excellent resistance to shocks / vibrations,
- High protection level IP65, IP67 option with a sealing flange,
- High performances in temperature -20°C to $+85^{\circ}\text{C}$,
- Parallel output - push pull electronic,
- Universal electronic circuits from 5 to 30Vdc,
- Protection against short-circuits and inversion of polarity,
- High resolutions available: 8192 (13 bits) per turn,
- Turn counting up to 65 536 (16 bits),
- Reset, Select, Latch, Direction functions,
- Option: push-button on the cover for an encoder reset to a value X.

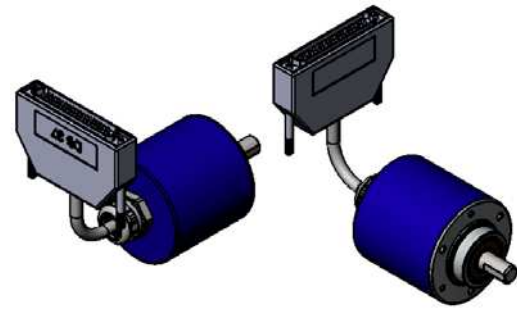

PHM5 PARALLEL DIMENSIONS

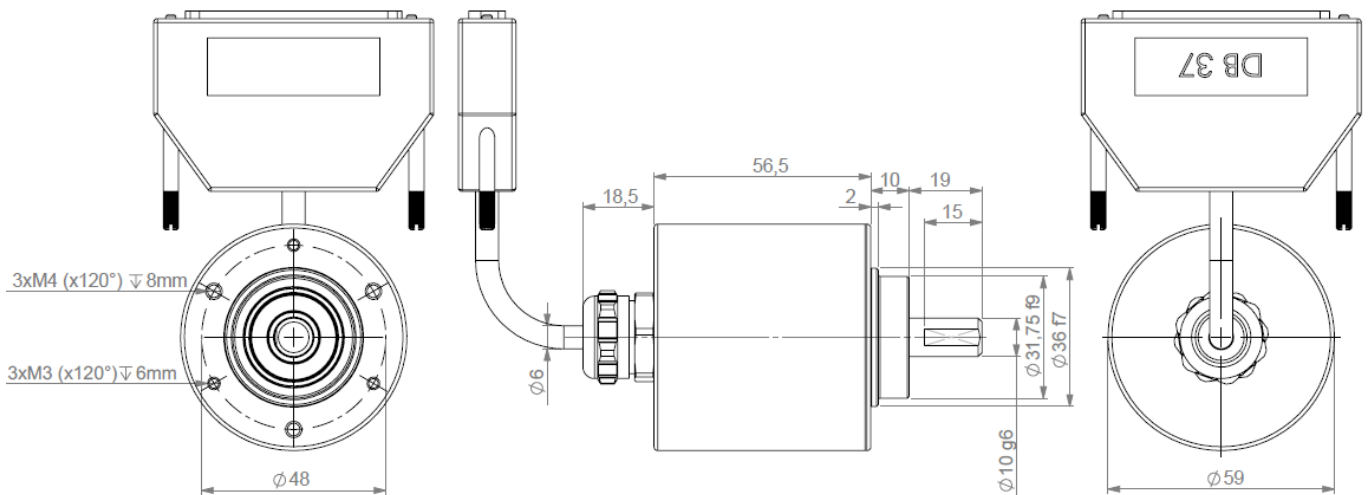

MECHANICAL CHARACTERISTICS

Material	Cover: steel	Shock (EN60068-2-27)	$\leq 500 \text{ m.s}^2$ (during 6 ms)
	Body: aluminium	Vibration (EN60068-2-6)	$\leq 100 \text{ m.s}^2$ (10... 2 000 Hz)
	Shaft: stainless steel	EMC	EN 61000-6-4, EN 61000-6-2
Bearings	6 000 serie	Isolation	100V (1 min.)
Maximum load	Axial: 50 N	Weight (connector)	0,750 kg
	Radial: 100 N	Operating temperature	$-20 \dots +85^{\circ}\text{C}$ (encoder ^T)
Shaft inertia	$\leq 1.10^{-6} \text{ kg.m}^2$	Storage temperature	$-20 \dots +85^{\circ}\text{C}$
Torque	$\leq 4.10^{-3} \text{ N.m}$	Protection (EN 60529)	IP 65 (IP67 with flange option)
Permissible max. speed	$6\,000 \text{ min}^{-1}$	Theoretical mechanical life time 10^9 turns (F_{axial} / F_{radial})	
Continuous max. speed	$6\,000 \text{ min}^{-1}$	25 N / 50 N : 99	50 N / 100 N : 12

SCHEMES

LATCH input

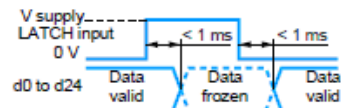

min. max.
Level "0" 0V 0.3 x V supply
Level "1" 0.7 x V supply V supply
I Latch < 5 mA

DIRECTION input

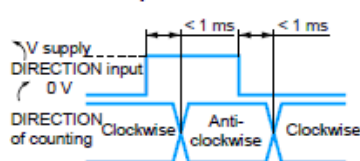

min. max.
Level "0" 0V 0.3 x V supply Increasing Clockwise
Level "1" 0.7 x V supply V supply Increasing Anticlockwise
I DIR < 5 mA

PUSH-PULL

Supply: 5 to 30 V \equiv
Max. ripple: 500 mV
Protection against reverse polarity
Max. no-load consumption: 100 mA (50 mA typical on 24 V)

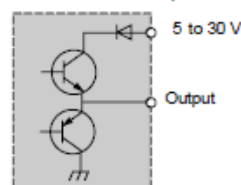

Max. current: 20 mA
Level "0" max.: 0.5 V
Level "1" min.: V supply - 2.5 V
Protection against short-circuits
NPN/PNP compatible

SELECT input

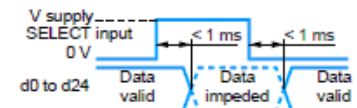

min. max.
Level "0" 0V 0.3 x V supply
Level "1" 0.7 x V supply V supply
I Select < 5 mA

Input stage - Reset to zero

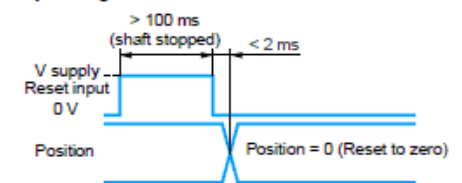

min. max.
Level "0" 0V 0.3 x V supply
Level "1" 0.7 x V supply V supply
I Reset < 5 mA

PARALLEL ABSOLUTE MULTITURN ENCODER - PUSH PULL - PHM5 RANGE

ELECTRONIC

Power supply	5 – 30Vdc
Introduction	< 1 s
Cons. without load	< 100mA (typically 50-60mA at 24Vdc)
Position refresh	< 200µs

PARALLEL CONNECTION

1	GN green	Output Bit 0
2	YE yellow	Output Bit 1
3	GY grey	Output Bit 2
4	PK pink	Output Bit 3
5	BU blue	Output Bit 4
6	RD red	Output Bit 5
7	BK black	Output Bit 6
8	VT violet	Output Bit 7
9	WH/BN white/brown	Output Bit 8
10	WH/GN white/green	Output Bit 9
11	WH/YE white/yellow	Output Bit 10
12	WH/GY white/grey	Output Bit 11
13	WH/PK white/pink	Output Bit 12
14	WH/BU white/blue	Output Bit 13
15	WH/RD white/red	Output Bit 14
16	WH/BK white/black	Output Bit 15
17	BN/GN brown/green	Output Bit 16
18	BN/YE brown/yellow	Output Bit 17
19	BN/GY brown/grey	Output Bit 18

20	BN/PK brown/pink	Output Bit 19
21	BN/BU brown/blue	Output Bit 20
22	BN/RD brown/red	Output Bit 21
23	BN/BK brown/black	Output Bit 22
24	GN/GY green/grey	Output Bit 23
25	GN/PK green/pink	Output Bit 24
26	GN/BU green/blue	Reserved
27	GN/RD green/red	RESET
28	GN/BK green/black	SELECT
29	YE/GY yellow/grey	LATCH
30	YE/PK yellow/pink	DIRECTION
31	YE/BU yellow/blue	Reserved
32	YE/RD yellow/red	Reserved
33	NC	Reserved
34	YE/BK yellow/black	Reserved
35	RD/BK red/black	Reserved
36	BN brown	5 to 30Vdc
37	WH white	0 Vdc

SELECT

Active data output, pin SELECT at 0Vdc
Non active data output: pin select to +Vcc

LATCH

Active data: pin LATCH to 0Vdc
Data frozen: pin LATCH to +Vcc

DIRECTION, LATCH, RAX and SELECT inputs have to be connected to 0Vdc or +Vcc (LATCH, SELECT and RAX at 0V if not used)
Reserved: Do not connect!

Example of pin assignment for configuration 10x7 bits: data available on pin 1 to 17 - Max: 25 bits (Resolution + Number of turns)

DIRECTION

Increasing code clockwise: pin DIRECTION at 0Vdc
Increasing code counterclockwise: Pin DIRECTION at +Vcc

RAX (PRESET to X):

For an electrical RAX (or push-button option): pin RAX to +Vcc during minimum 100ms.

ORDERING REFERENCE (Contact the factory for special versions, ex: special flanges, connections, electronics...)

	Shaft Ø	Supply	Output stage	Code	Resolution	Number of turns	Connection	Orientation
PHM5	10 :	P :	S5 :	G :	13 :	B12	S3	A010 :
	10mm							
	06 :			B	Nota: Available from 0 to 13 bits	Nota: Available from 0 to 16 bits		
	6mm			Binary		Max: 25 bits (Resolution + Number of turns)		
PHM5_	10 //	P	S5	G //	13	B12 //	S3	A010

Made in France