

CANOPEN ABSOLUTE MULTI-TURN ENCODER, MHM510-CANO RANGE

- MHM510-CANO, standard encoder Ø58mm with CANopen interface:
- Robust and compact design
- Solid shaft version Ø 10 mm (Ø6 mm available upon request)
- Precision ball bearings with sealing flange
- High temperatures performances -40°C ... +85°C
- Code disc made of unbreakable and durable plastic
- Mechanical memorisation of the number of turns by gears
- Resolution : 13 bits = 8192 steps/turn (max 16 bits)
- Number of turns : 12 bits = 4096 turns (max 14 bits)
- Polarity inversion and short circuit protection
- Highly integrated circuit in SMD-technology

CANopen



MHM510-CANO (connection cap included)

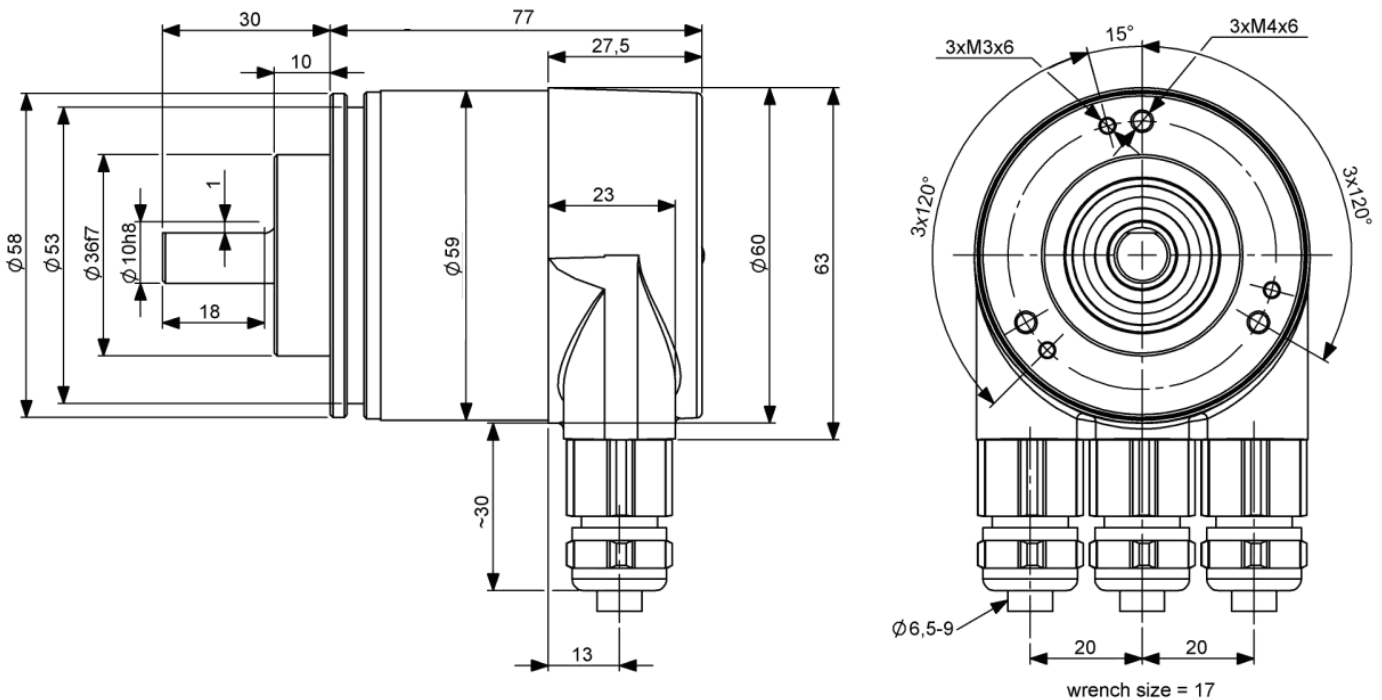

Status indication with two LED's in the connection cap

The LED behaviour was designed in accordance to the CiA normative DR 303-3 CANopen indicator specification

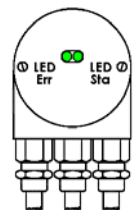

MECHANICAL DATA

Material Stainless steel option	Cover : aluminum	Vibrations (EN 60068-2-6)	≤ 10 g (10Hz... 1 000Hz)		
	Body : aluminum		Weight	600 g	
	Shaft: stainless steel			Operating temperature	- 40 ... + 85°C
Max. shaft loading	Axial : 40 N	Storage temperature			- 40 ... + 85°C
	Radial : 110 N		Humidity		98 % without condensation
Shaft Inertia	≤ 30 g.cm ²			Protection class (EN 60529)	IP 65: body
Torque	≤ 3 N.cm	IP 64: shaft			
RPM (continuous operation))	6 000 rpm	Lifetime in 10 ⁸ revolutions with F _a / F _r (axial / radial)			
Shock (EN 60068-2-27))	≤ 100 g (halfsinus, 6 ms)	40 N / 60 N	40 N / 80 N	40 N / 110 N	
		25	10	4	
Shock (EN 60028-2-29)	≤ 10 g (half-sinus, 16ms)				

CANOPEN ABSOLUTE MULTI-TURN ENCODER, MHM510-CANO RANGE

ELECTRICAL DATA

Interface	ISO 11898	Power consumption	max 2,5W
Transmission rate	Max 1 MBauds	Step Frequency LSB	800 kHz
Device addressing	by rotary switches	Accuracy	+ 1/2 LSB
Power supply	10 – 30Vdc	EMC	EN 61000-6-4 EN 61000-6-2
Current consumption	max 100mA (24Vdc)	Electrical lifetime	> 10 ⁵ h

TRANSMISSION MODES

POLLED Mode	By a remote-transmission-request telegram the connected host calls for the current process value. The absolute rotary encoder reads the current position value, calculates eventually set-parameters and sends back the obtained process value by the same identifier
CYCLIC Mode	The absolute rotary encoder transmits cyclically - without being called by the host - the current process value. The cycle time can be programmed in milliseconds for values between 1 ms and 65536 ms
SYNC Mode	After receiving a sync telegram by the host, the absolute rotary encoder answers with the current process value. If more than one node number (encoder) shall answer after receiving a sync telegram, the answer telegrams of the nodes will be received by the host in order of their node numbers. The programming of an offset-time is not necessary. If a node should not answer after each sync telegram on the CAN network, the parameter sync counter can be programmed to skip a certain number of sync telegrams before answering again

PROGRAMMABLE PARAMETERS

Operating Parameters	This parameter determines the counting direction, in which the output code increases or decreases. As an important operating parameter the code sequence (complement) can be programmed
Resolution per turn	Value between 1 and 8192 can be programmed
Total resolution "Max range"	This parameter is used to program the desired number of measuring units over the total measuring range. This value may not exceed the total resolution of the absolute rotary encoder.
Preset Value	The preset value is the desired position value, which should be reached at a certain physical position of the axis
Limit Switch, Min. and Max	Two position values can be programmed as limit switches. By reaching these values one bit of the 32 bit process value is set to high level
Cam	One free programmable cam can be set in the total measuring range

INSTALLATION

The rotary encoder is connected by two or three cables depending on whether the power supply is integrated into the bus cable or connected separately. If the power supply is integrated into the bus cable, one of the cable glands can be fitted with a plug. The cable glands are suitable for cable diameters from 5.5 up to 9 mm

CONFIGURATION

The setting of the node number is achieved by 2 turn-switches in the connection cap. Possible addresses lie between 0 and 89 whereby every address can only be used once. Inside the encoder the defined address is increased by one. The connection cap can easily be opened for installation by removing the two cap screws

A termination resistor is integrated in the connection cap. The resistor must be switched on if the encoder is connected at the end or at the beginning of the bus

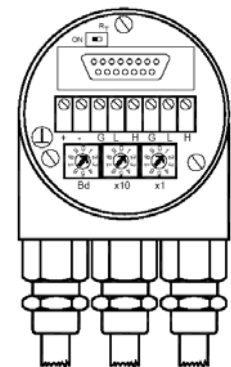

ORDERING REFERENCE (Contact the factory for special versions ex:electronics, special flanges, connections...)

MHM5	CA	A1	B	12	13	C	10	0	HBP
Absolute multi turn encoder	CANopen	Version	Code : Binary	Number of turns 2 ¹² (4 096)	Resolution : 2 ¹³ (8 192)	Clamp flange	Shaft diameter : 10mm	Without mechanical option	Connection Cap

Note: The "H3P" terminal box version is shorter than the "0CC" one.