

H25X Absolute Optical Encoder



The H25X series single turn encoder is designed for those applications that require 14 or 15 bits of resolution in a compact, easy-to-integrate package. Gray Code and Natural Binary outputs are available for installations using a parallel input with the controller. For simplicity of data transmission, ease of cabling and better noise immunity, an SSI (Serial Synchronous Interface) is also offered. This encoder works with the BEI Serial-to-Parallel converter, allowing for system upgrades from parallel output to SSI.



The H25X is built to the exacting mechanical standards used with the H25 design, including: dual preloaded ABEC 7 bearings; matched thermal coefficients on critical components and electronically centered code disks for high accuracy and stability over a range of environments. Specify the H25X when you need high pointing accuracy and ruggedness in a 14 or 15 bit absolute encoder for your telescope, antenna, robotics, material handling or general industrial automation.

The H25 Absolute Encoder is available with the following certification:

EN 55011 and EN 61000-6-2

Mechanical Specifications

- Shaft Diameter:** 3/8"
- Shaft Loading:** Up to 25 pounds axial and radial
- Shaft Runout:** 0.0005 T.I.R. at midpoint regardless of shaft diameter
- Starting Torque at 25°C:** With shaft seal 2.5 in-oz
- Bearings:** Class ABEC 7 standard, ABEC 5 for 1/2" shaft
- Shaft Material:** 416 stainless steel
- Bearing Housing:** Die cast aluminum with iridite finish
- Cover:** Die cast aluminum
- Bearing Life:** 2 X 10⁶ revs (1300 hrs at 2500 RPM) at rated load
1 X 10¹⁰ revs (67,000 hrs at 2500 RPM) at 10% of rated load
- Maximum RPM:** 12,000 RPM mechanical,
- Moment of Inertia:** 4.1 X 10⁻⁴ oz-in-sec²
- Weight:** 13 oz typical
- Connector:** MS3112E14-19P, 19-pin connector on encoder body, mates to MS3116J14-19S (or equivalent)

Electrical Specifications

- Code:** 14 or 15 bits NB or GC
- Counts Per Shaft Turn:** 16,384 or 32,768
- Count Transition Accuracy:** ± 1/2 bit maximum
- Supply Voltage:** 5–28 VDC
- Current Requirements:** 120 mA typical
- Output Formats:**
Parallel: Gray Code, Natural Binary
Serial: Serial Synchronous Interface (SSI) compatible
- Voltage/Output:** (see note 4)
28V/V: Line Driver, 5–28 VDC in, V_{out} = V_{in}
28V/5: Line Driver, 5–28 VDC in, V_{out} = 5 VDC
28V/OC: Open Collector, 5–28 VDC in, OCout
SSI: 5–28 VDC IN/5Vout (see back page)
- Protection Level:** Reverse, overvoltage and output short circuit protection (see note 3)
- Frequency Response:** 500kHz
- Output Termination Pinouts:** see Table 1, back page

Environmental Specifications

- Enclosure Rating:** NEMA 4 & 13 (IP 66) when ordered with shaft seal (on units with an MS connector) or a cable gland (on units with cable termination).
- Temperature:** Operating, 0° to 70° C; extended temperature testing available (see note 7); Storage, -25° to 90° C unless extended temperature option called out.
- Shock:** 50 g's for 11 msec duration
- Vibration:** 5 to 2000 Hz @ 20 g's
- Humidity:** 98% RH without condensation

NOTES & TABLES: All notes and tables referred to in the text can be found on the back of this page.

H25X Absolute Encoder Ordering Options

FOR ASSISTANCE CALL 800-350-2727

Use this diagram, working from left to right to construct your model number (example: H25XD-F4-SS-14GC-28V/V-CW-SM14/19).

All notes and tables referred to can be found on the back of this page.

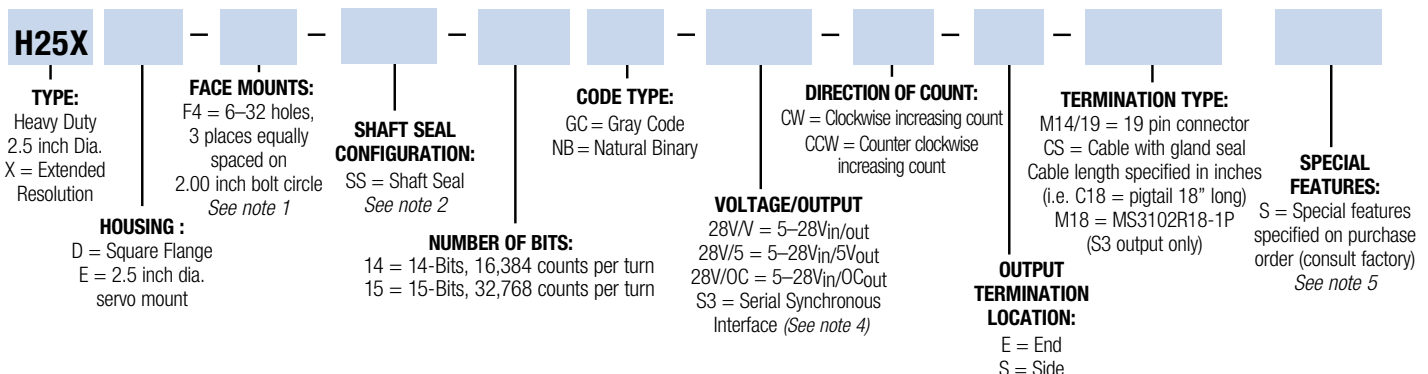

Tel: 805-968-0782 / 800-350-2727 | Fax: 805-968-3154 / 800-960-2726
7230 Hollister Ave., Goleta, CA 93117-2807 | www.beisensors.com

Specification No. 02085-001 Rev.08-11

H25X Absolute Optical Encoder



Serial Synchronous Interface (SSI)

SSI output provides effective synchronization in a closed-loop control system. A clock pulse train from a controller is used to clock out sensor data: one bit of position data is transmitted to the controller per one clock pulse received by the sensor. The use of a differential driver permits reliable transmission of data over long distances in environments that may be electrically noisy. The encoder utilizes a clock signal, provided by the user interface, to time the data transmission. Receiving electronics must include an appropriate receiver as well as line terminating resistors.

Features :

- Synchronous transmission
- Transmission lengths to 1000 feet
- Accepts clock rates from 100 KHz to 1.8 MHz

Data Transmission Sequence

1. Output driver of the encoder is a MAX 491 transceiver in transmit mode. The recommended receiver is a MAX 491 transceiver in receive mode.
2. Controller provides a series of pulses (or differential pulse pairs) on the CLOCK input lines.
3. On the first HIGH-to-LOW CLOCK transition, the encoder latches its data at the current position and prepares to transmit.
4. Controller reads data on the falling edge of the next 15 clock cycles.
5. The first bit is a START bit and is always HIGH.
6. Next comes 13 data bits beginning with the most significant bit (MSB) and ending with the parity bit. On 12 bit encoders, bit 13 is LOW. When parity is not ordered, parity is LOW.
7. After the last CLOCK HIGH-to-LOW transition, a minimum of 40 microseconds must pass before the beginning of the next CLOCK series.

Interfacing Long Data Lines

Cable impedance can create a transmission delay, in effect, shifting the phase relationship between the clock pulse and the data. If this phase shift exceeds 180°, then the wrong bit position will be sampled by the receiver. As a result, the maximum allowable clock frequency is a function of the cable length. For 24 AWG, stranded, 3 pair cable (BEI part number 37048-003 or equivalent) the group delay is 1.36ns/ft. The table below shows the maximum transmission rate allowable as a function of cable length to ensure a phase shift of less than 90°.

CLOCK, Maximum (kHz) =	92,000 / Cable Length (ft)CW					
Cable Length (ft)	50	100	200	300	500	1000
Max Freq (kHz)	1800	900	500	300	200	100

Parallel Code (14 & 15 Bit) ²						
	Gray Code		Natural Binary		M14/19 Connector	Cable
	14 BIT	15 Bit	14 BIT	15 Bit		
MSB	G ₁₃	G ₁₄	2 ¹³	2 ¹⁴	A	WHT/BLK
	G ₁₂	G ₁₃	2 ¹²	2 ¹³	B	WHT/BRN
	G ₁₁	G ₁₂	2 ¹¹	2 ¹²	C	WHT/RED
	G ₁₀	G ₁₁	2 ¹⁰	2 ¹¹	D	WHT/ORN
	G ₉	G ₁₀	2 ⁹	2 ¹⁰	E	WHT/YEL
	G ₈	G ₉	2 ⁸	2 ⁹	F	WHT/GRN
	G ₇	G ₈	2 ⁷	2 ⁸	G	WHT/BLU
	G ₆	G ₇	2 ⁶	2 ⁷	H	WHT/VIO
	G ₅	G ₆	2 ⁵	2 ⁶	J	WHT/GRY
	G ₄	G ₅	2 ⁴	2 ⁵	K	WHT
	G ₃	G ₄	2 ³	2 ⁴	L	GRY/BLK
	G ₂	G ₃	2 ²	2 ³	M	GRY/BRN
	G ₁	G ₂	2 ¹	2 ²	N	GRY/RED
LSB14	G ₀	G ₁	2 ⁰	2 ¹	P	GRY/ORN
LSB15	DIR CONTROL	G ₀	DIR CONTROL	2 ⁰	R	*
	CASE GROUND				S	GRN
OV (CIRCUIT COMMON)				T	BLK	
LATCH	DIR/LATCH	LATCH	DIR/LATCH	U	*	
+V (SUPPLY VOLTAGE)	+V (SUPPLY VOLTAGE)	+V (SUPPLY VOLTAGE)	+V (SUPPLY VOLTAGE)	V	RED	
SHIELD DRAIN				—	BARE	

* DIR Control - ORN, LATCH - YEL, 15 bit LSB-GRY/YEL

² Units Manufactured before April 2007 are LSB Justified

Ordering SSI : HOW TO SPECIFY SSI OUTPUT IN THE ENCODER MODEL NUMBER: Use the designation, S3 between the Code Format designation and the Connector designation. Example: H25D-SS-126C-S3-CW-SM18

Notes

1. Mounting is usually done either using the D-style square flange mount, E- or G-style servo mounts, or one of the standard face mounts, F1 for example. Consult factory for additional face mount options.
2. The shaft seal is recommended in virtually all installations. The most common exceptions are applications requiring a very low starting torque or those requiring operation at both high temperature and high speed.
3. Complementary outputs are recommended for use with line driver type (source/sink) outputs. When used with differential receivers, this combination provides a high degree of noise immunity.
4. Output IC's: Output IC's are available as either Line Driver (LD) or NPN Open Collector (OC) types. Open Collectors require pull-up resistors, resulting in higher output source impedance (sink impedance is similar to that of line drivers). In general, use of a Line Driver style output is recommended. Line Drivers source or sink current and their lower impedance mean better noise immunity and faster switching times. **Warning:** Do not connect any line driver outputs directly to circuit common/OV, which may damage the driver. Unused outputs should be isolated and left floating. Our applications specialists would be pleased to discuss your system requirements

- and the compatibility of your receiving electronics with Line Driver type outputs.
- 28V/V:** Multi-voltage Line Driver (7272*): 100 mA source/sink. Input voltage 5 to 28 VDC +/- 5% standard (Note: V_{out} = V_{in}). This driver is TTL compatible when used with 5 volt supply. Supply lines are protected against overvoltage to 60 volts and reverse voltage. Outputs are short circuit protected for one minute. Supply current is 120 mA typical (plus load current). This is the recommended replacement for 3904R and 7406R open collector outputs with internal pullup resistors. It is also a direct replacement for any 4469, 88C30, 8830 or 26LS31 line driver.
- 28V/5:** Multi-voltage Line Driver (7272*): 100 mA source/sink. Input voltage 5 to 28 VDC +/- 5% standard, internally regulated with 5V (TTL compatible) logic out. Supply lines are protected against overvoltage to 60 volts and reverse voltage. Outputs are short circuit protected for one minute. Supply current is 90 mA typical (plus load current). **Note:** Limit encoder load to 2.5W max at ambient. Example at 12 VDC: 2.5W/(+12VDC minus +5VDC) = 357 mA total allowed current. Consult factory for your specific requirements.
- 28V/OC:** NPN Open Collector (3904*, 7273*). Current

SSI Output Termination Table			
	M18 Conn	M14/19 Conn	Cable Conn
DATA +	A	A	YEL
DATA-	H	B	WHT/YEL
CLOCK+	B	C	BLU
CLOCK-	I	D	WHT/BLU
DIR CONTROL	C	R	ORN
CASE GROUND	G	S	GRN
CIRCUIT COMMON	F	T	BLK
+V SUPPLY VOLTAGE	D	V	RED
SHIELD DRAIN	—	—	BARE

Direction of Count: Standard is CW increasing when viewed from the shaft end. Pin R is normally HI (or N/C) and is pulled up internally to +V. To reverse the count direction, Pin R must be pulled LO (COMMON).

Latch control: Encoder outputs are active and provide continuous parallel position information when Pin U is HI (or N/C). Pin U is pulled up internally to +V. When Pin U is LO (COMMON) the encoder outputs are latched at the logic state that is present when the latch is applied and will stay latched until Pin U is no longer grounded.

Dir/Latch on 15-Bit Encoders: Due to a limited number of connector pins, either direction of count or latch is available on pin U. Direction standard of latch specified as -S special.

M18 Connector is a MS3102R18-1P, 10-pin connector on the encoder body and mates to an MS3106F18-1S connector or can be used with a standard cable/connector assembly, BEI P/N 924-31186-18XX (Where XX = 10, 20 30 or 50 for a 10, 20, 30, or 50 foot length). This is the preferred connector for SSI output.

M14/19 Connector is a MS3112E14-19P, 19-pin connector on the encoder body and mates to an MS3116J14-19S or equivalent.

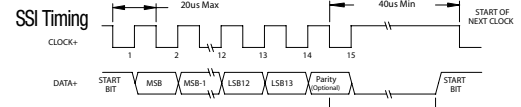

Figures

Figure 1
Gray Code

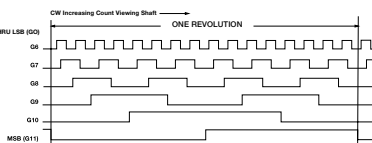
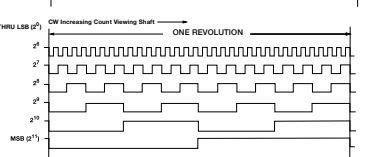
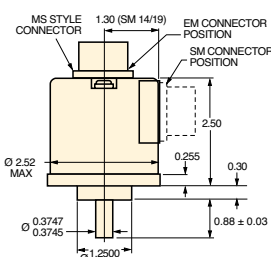

Figure 2
Natural Binary



Dimensions

H25XD - Square Flange



H25XE - 2.50 Servo Mount

