

HS35 Absolute Encoder



Built on the same rugged design as the incremental model, the HS35 Absolute Encoder is available with various output options including Gray Code and Natural Binary. Designed with a cast aluminum housing, a sealed connector and shaft seals, it carries an IP65 environmental rating. With the optional insulating inserts, it can be mounted on smaller diameter shafts. It is designed for either a through shaft mounting or blind shaft mounting with a closed cover to maintain its environmental rating.

The H25 Incremental Encoder is available with the following certification:

EN 55011 and EN 61000-6-2

Electrical Specifications

Code: 12 or 13 bits NB or GC
Counts Per Shaft Turn: 4096 or 8192 (with S3 option only)
Count Transition Accuracy: $\pm 1/2$ bit maximum
Supply Voltage: 5–28 VDC
Current Requirements: 120 mA typical
Output Formats: Parallel: Gray Code, Natural Binary
Voltage/Output: (see note 2)
 28V/V: Line Driver, 5–28 VDC in, $V_{out} = V_{in}$
 28V/5: Line Driver, 5–28 VDC in, $V_{out} = 5$ VDC
 28V/OC: Open Collector, 5–28 VDC in, OC_{out}
 SSI: 5–28 VDC in/ $5V_{out}$ (consult factory for more information)
Protection Level: Reverse, overvoltage and output short circuit protection
Frequency Response: 100kHz (1200 RPM for 12-bits)
Output Termination Pinouts: see tables, back page

Mechanical & Environmental Specs

Shaft Bore: 1.000, 0.875, 0.750, 0.625, 0.500. Diameters under 0.875 are supplied with insulated sleeves.
Allowable Misalignment: 0.005" T.I.R. on mating shaft 0.75" from shaft end
Bore Runout: 0.001 T.I.R. maximum
Starting Torque at 25°C: Through shaft version (SS) = 7 in-oz (max); Blind shaft version (BS) = 4 in-oz max
Bearings: 52100 SAE High carbon steel
Shaft Material: 416 Stainless Steel
Bearing Housing: Die cast aluminum with protective finish
Cover: Die cast aluminum with protective finish
Bearing Life: 7.5 X 10⁹ revs (50,000 hours @ 2500 RPM)
Maximum RPM: 6,000 mechanical (see frequency response, above)
Moment of Inertia: 0.019 oz-in-sec²
Weight: 18oz typical

Connector

MS3112E14-19P, 19-pin connector on encoder body, mates to MS3116J14-19S (or equivalent)

NOTES & TABLES: All notes and tables referred to in the text can be found on the back of this page.

HS35 Absolute Encoder Ordering Options

FOR ASSISTANCE CALL 800-350-2727

Use this diagram, working from left to right to construct your model number (example: HS35F-100-R1-SS-12GC-28V/V-CW-SM14/19).

All notes and tables referred to can be found on the back of this page.

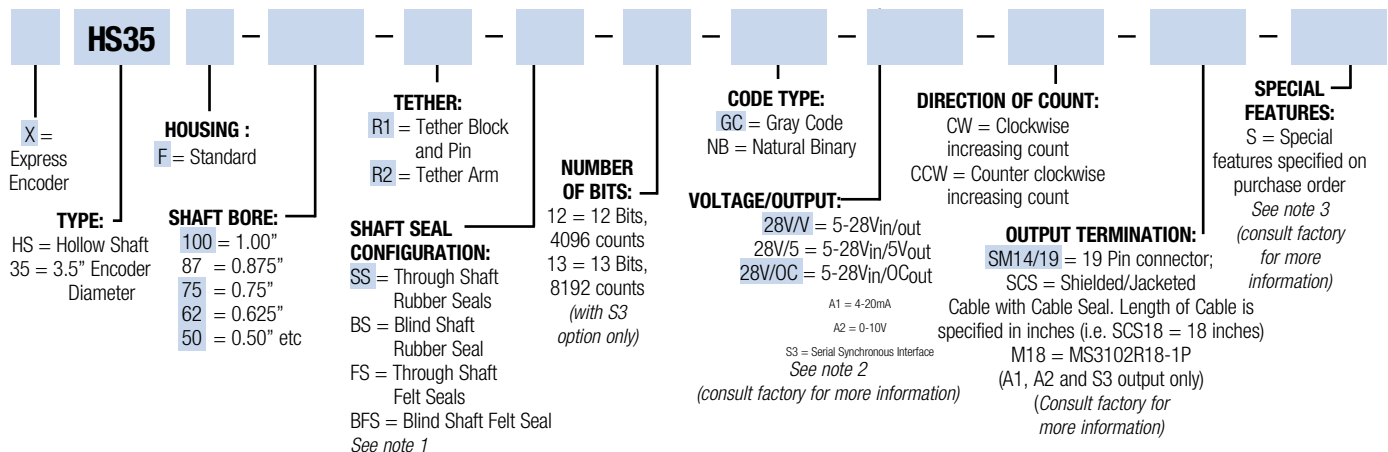

EXPRESS ENCODERS: Items highlighted with are standard Express Encoders and ship in one to three days.



Tel: 805-968-0782 / 800-350-2727 | Fax: 805-968-3154 / 800-960-2726
 7230 Hollister Ave., Goleta, CA 93117-2807 | www.beisensors.com

Specification No. 02070-001 Rev.07-12

Serial Synchronous Interface (SSI)

SSI output provides effective synchronization in a closed-loop control system. A clock pulse train from a controller is used to clock out sensor data: one bit of position data is transmitted to the controller per one clock pulse received by the sensor. The use of a differential driver permits reliable transmission of data over long distances in environments that may be electrically noisy. The encoder utilizes a clock signal, provided by the user interface, to time the data transmission. Receiving electronics must include an appropriate receiver as well as line terminating resistors.

Features :

- Synchronous transmission
- Transmission lengths to 1000 feet
- Accepts clock rates from 100 KHz to 1.8 MHz

Data Transmission Sequence

1. Output driver of the encoder is a MAX 491 transceiver in transmit mode. The recommended receiver is a MAX 491 transceiver in receive mode.
2. Controller provides a series of pulses (or differential pulse pairs) on the CLOCK input lines.
3. On the first HIGH-to-LOW CLOCK transition, the encoder latches its data at the current position and prepares to transmit.
4. Controller reads data on the falling edge of the next 15 clock cycles.
5. The first bit is a START bit and is always HIGH.
6. Next comes 13 data bits beginning with the most significant bit (MSB) and ending with the parity bit. On 12 bit encoders, bit 13 is LOW. When parity is not ordered, parity is LOW.
7. After the last CLOCK HIGH-to-LOW transition, a minimum of 40 microseconds must pass before the beginning of the next CLOCK series.

Interfacing Long Data Lines

Cable impedance can create a transmission delay, in effect, shifting the phase relationship between the clock pulse and the data. If this phase shift exceeds 180°, then the wrong bit position will be sampled by the receiver. As a result, the maximum allowable clock frequency is a function of the cable length. For 24 AWG, stranded, 3 pair cable (BEI part number 37048-003 or equivalent) the group delay is 1.36ns/ft. The table below shows the maximum transmission rate allowable as a function of cable length to ensure a phase shift of less than 90°.

CLOCK, Maximum (kHz) =
92,000 / Cable Length (ft)CW

Cable Length (ft)	50	100	200	300	500	1000
Max Freq (kHz)	1800	900	500	300	200	100

Output Code and Terminations					
	PARALLEL CODE		TERMINATION TYPE		
	Gray Code	Natural Binary	Cable	M14/19 Conn	
	12 Bit	12 Bit			
MSB	G ₁₁	2 ¹¹	WHT/BLK	A	
	G ₁₀	2 ¹⁰	WHT/BRN	B	
	G ₉	2 ⁹	WHT/RED	C	
	G ₈	2 ⁸	WHT/ORN	D	
	G ₇	2 ⁷	WHT/YEL	E	
	G ₆	2 ⁶	WHT/GRN	F	
	G ₅	2 ⁵	WHT/BLU	G	
	G ₄	2 ⁴	WHT/IO	H	
	G ₃	2 ³	WHT/GRY	J	
	G ₂	2 ²	WHT	K	
LSB ₁₂	G ₁	2 ¹	GRY/BLK	L	
	G ₀	2 ⁰	GRY/BRN	M	
LSB ₁₃			GRY/RED	N	
0V (CIRCUIT COMMON)			GRY/ORN	P	
DIRECTION OF COUNT			ORN	R	
CASE GROUND			GRN	S	
0V (CIRCUIT COMMON)			BLK	T	
LATCH CONTROL			YEL	U	
+V (SUPPLY VOLTAGE)			RED	V	
SHIELD DRAIN			BARE	—	

*Pin P is available for a tri-state option

Ordering SSI : HOW TO SPECIFY SSI OUTPUT IN THE ENCODER

MODEL NUMBER: Use the designation, S3 between the Code Format designation and the Connector designation.

Example: H25D-SS-12GC-S3-CW-SM18

Dimensions

MS Connector Termination

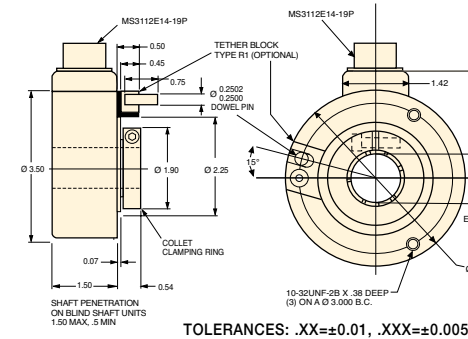

R1 Tether Block and Pin

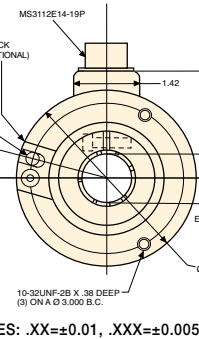

R2 Tether Arm

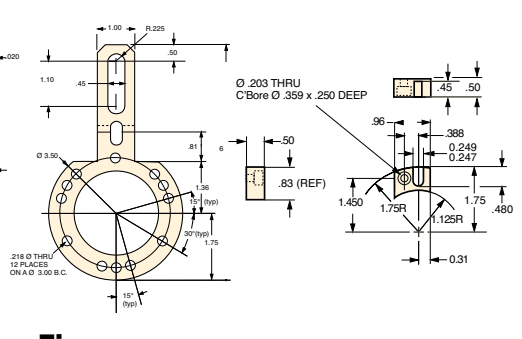

SSI Output Termination Table			
	M18 Conn	M14/19 Conn	Cable Conn
DATA +	A	A	YEL
DATA-	H	B	WHT/YEL
CLOCK+	B	C	BLU
CLOCK-	I	D	WHT/BLU
DIR CONTROL	C	R	ORN
CASE GROUND	G	S	GRN
CIRCUIT COMMON	F	T	BLK
+V SUPPLY VOLTAGE	D	V	RED
SHIELD DRAIN	—	—	BARE

Direction of Count: Standard is CW increasing when viewed from the shaft end. Pin R is normally HI (or N/C) and is pulled up internally to +V. To reverse the count direction, Pin R must be pulled LO (COMMON).

Latch control: Encoder outputs are active and provide continuous parallel position information when Pin U is HI (or N/C). Pin U is pulled up internally to +V. When Pin U is LO (COMMON) the encoder outputs are latched at the logic state that is present when the latch is applied and will stay latched until Pin U is no longer grounded.

M18 Connector is a MS3102R18-1P, 10-pin connector on the encoder body and mates to an MS3106F18-1S connector or can be used with a standard cable/connector assembly, BEI P/N 924-31186-18XX (Where XX = 10, 20, 30 or 50 for a 10, 20, 30, or 50 foot length). This is the preferred connector for SSI output.

M14/19 Connector is a MS3112E14-19P, 19-pin connector on the encoder body and mates to an MS3116J14-19S or equivalent.

SSI Timing

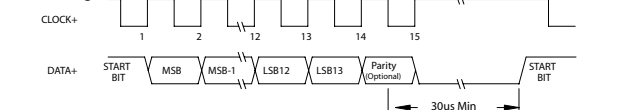

Notes

1. The rubber shaft seal is recommended in virtually all installations. The most common exceptions are applications requiring a very low starting torque or those requiring operation at both high temperature and high speed. For these exceptions, a felt shaft seal is recommended. Felt seals require very low starting torque and can virtually eliminate frictional heat. Encoders ordered with felt shaft seals will have an enclosure rating of IP50 and will have less than 1/10th the Starting Torque specified under Mechanical Configurations.
2. **Output IC's:** Output IC's are available as either Line Driver (LD) or NPN Open Collector (OC) types. Open Collectors require pull-up resistors, resulting in higher output source impedance (sink impedance is similar to that of line drivers). In general, use of a Line Driver style output is recommended. Line Drivers source or sink current and their lower impedance mean better noise immunity and faster switching times. **Warning:** Do not connect any line driver outputs directly to circuit common/OV, which may damage the driver. Unused outputs should be isolated and left floating. Our applications specialists would be pleased to discuss your system requirements and the compatibility of your receiving electronics with Line Driver type outputs.
3. **28V/V:** Multi-voltage Line Driver (7272*): 100 mA source/sink. Input voltage 5 to 28 VDC +/- 5% standard (Note: V_{out} = V_{in}). This driver is TTL compatible when used with 5 volt supply. Supply lines are protected against overvoltage to 60 volts

- and reverse voltage. Outputs are short circuit protected for one minute. Supply current is 120 mA typical (plus load current). This is the recommended replacement for 3904R and 7406R open collector outputs with internal pullup resistors. It is also a direct replacement for any 4469, 88C30, 8830 or 26LS31 line driver
- 28V/5:** Multi-voltage Line Driver (7272*): 100 mA source/sink. Input voltage 5 to 28 VDC +/- 5% standard, internally regulated with 5V (TTL compatible) logic out. Supply lines are protected against overvoltage to 60 volts and reverse voltage. Outputs are short circuit protected for one minute. Supply current is 90 mA typical (plus load current). **Note:** Limit encoder load to 2.5W max at ambient. Example at 12 VDC: 2.5W/(+12VDC minus +5VDC) = 357 mA total allowed current. Consult factory for your specific requirements.
- 28V/OC:** NPN Open Collector (3904*, 7273*). Current limit of 80 mA max. Current sourced by external pull-up resistor. Output can be pulled up to voltage other than supply voltage (30 V max). Input voltage 5 to 28 VDC +/- 5% standard. Supply current is 120 mA typical. This replaces prior IC's with designations of 3904, 7406, 3302, 681 and 689.
3. Special -S at the end of the model number is used to define a variety of non-standard features such as special shaft lengths, voltage options, or special testing. Please consult the factory to discuss your special requirements.

* Products manufactured prior to April 2007 used the line driver IC number instead of voltage output in model number.

Figures

Figure 1
Gray Code

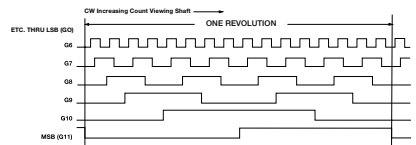

Figure 2
Natural Binary

