

DNV-50 SERIES, 50WATT, 2:1 INPUT RANGE
FEATURES:

- ✓ 3 years warranty
- ✓ 1500Vac isolation voltage
- ✓ Six-side shielded metal case with low ripple and noise
- ✓ Operating temperature range -40°C to +85°C
- ✓ Over voltage, over current, short circuit protection
- ✓ Remote on/off
- ✓ Adjustable output voltage



Model	Input voltage (Vdc)	Output voltage (Vdc)	Output current (A)	Efficiency Typ.
DNV50-1211	12(9~18)	5.1	10	89%
DNV50-1212		12.1	4.2	89%
DNV50-1213		15.1	3.3	89%
DNV50-2411	24(18~36)	5.1	10	88%
DNV50-2412		12.1	4.2	89%
DNV50-2413		15.1	3.3	89%
DNV50-2414		24.2	2	89%
DNV50-2415		48.2	1	87%
DNV50-4811	48(36~72)	5.1	10	88%
DNV50-4812		12.1	4.2	89%
DNV50-4813		15.1	3.3	89%
DNV50-4814		24.2	2	89%
DNV50-4815		48.2	1	89%
DNV50-11011	110(66~160)	5.1	10	89%
DNV50-11012		12.1	4.2	89%
DNV50-11013		15.1	3.3	89%
DNV50-11014		24.2	2	89%

Notes:

1. Other input and output models may available on request;
2. You may request for the models with heatsink, plus "R" in the suffix, e.g. DNV50-1211R.

DNV-50 SERIES, 50WATT, 2:1 INPUT RANGE

ELECTRICAL		
Input voltage range	12V	9-18Vdc
	24V	18-36Vdc
	48V	36-72Vdc
	110V	60-166Vdc
Remote control	REM left open	Output on
	REM connect with -Vin	Output off
Input under voltage protection	When input voltage is lower than the low terminal input voltage	Auto-recovery
Output voltage accuracy	---	≤1%
Output voltage adjustable	---	±10% max.
Line regulation	Nominal Load, full voltage	±0.2% max.
Load regulation	20% ~ 100% rated load	±0.5% max.
Dynamic response (transient/recovery time)	5%-50%-75% load capability	$\Delta V_o/\Delta t$: ±5.0%/400 μ s
Ripple and noise	20MHz BM, full load	1% Vout max.
Isolation voltage (<2mA/min)	Input to output	1500Vac
	Input to case	1500Vac
	Output to case	500Vac
Isolation resistance	500Vdc	100M Ω
Temperature coefficient	---	±0.02%/°C max.
Operating temperature range	Auxiliary heat sink	-40°C to +85°C
Storage temperature range	---	-45°C to +120°C
Cooling method	50W need external heatsink	Cooling by air convection
Over current protection	---	Auto-recovery
Short circuit protection	---	Continuous auto-recovery
Over voltage protection	---	Auto-recovery
Relative humidity	---	10%-90% max.
Weight	---	95g
MTBF	Bellcore TR-332, 25°C	2x10 ⁵ Hrs

Notes: Unless otherwise specified, all the parameters of the test conditions are as follows: ambient temperature 25°C, the nominal input voltage, pure resistive nominal load.

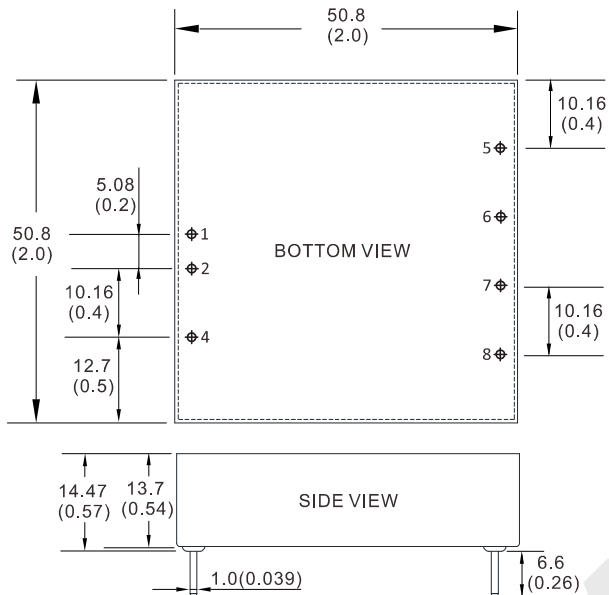
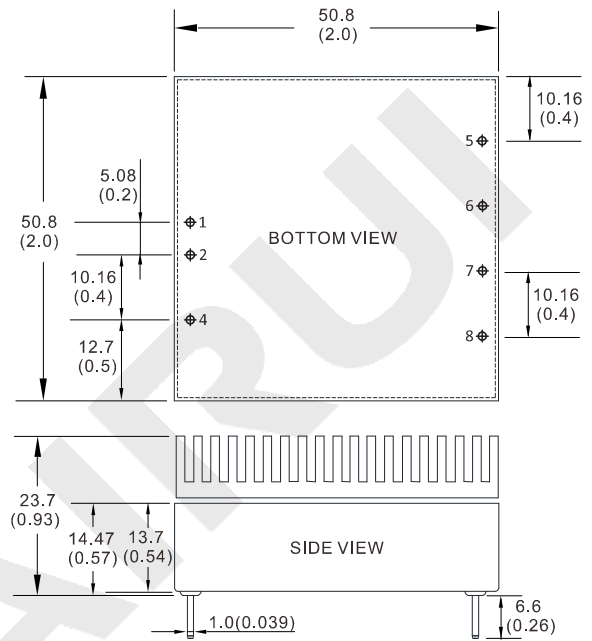
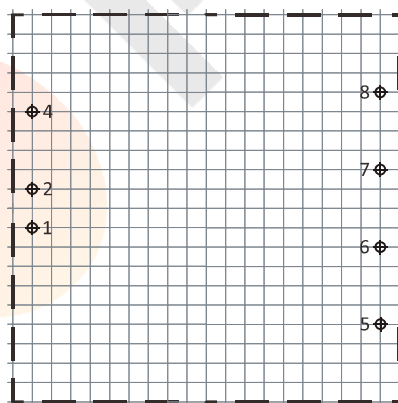
DNV-50 SERIES, 50WATT, 2:1 INPUT RANGE
MECHANICAL
WITHOUT HEATSINK

WITH HEATSINK

PCB LAYOUT

Unit : mm(inch)
PCB vertical view
Grid spacing: 2.54mm(0.1 inch)

CONNECTION

PIN #	SINGLE
1	+Vin
2	-Vin
4	REM
5	No Pin
6	+Vo
7	GND
8	ADJ

Note:

* Unit is mm(inch).

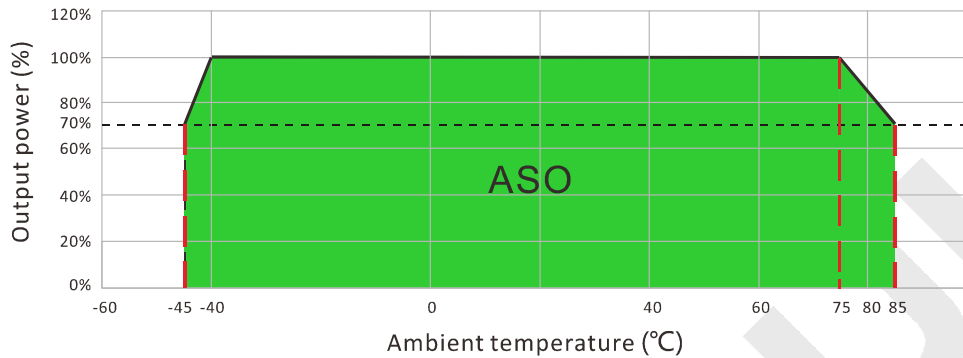
DNV-50 SERIES, 50WATT, 2:1 INPUT RANGE
TEMPERATURE PROFILE

CAPACITIVE LOADS SELECTION

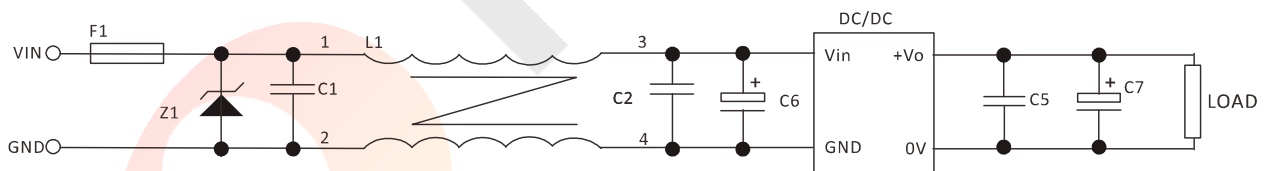
Vout: 3.3V 5V		Vout: 12V 5V		Vout: 24V	
Recommended value	MAX. value	Recommended value	MAX. value	Recommended value	MAX. value
4700 μ F	10000 μ F	1000 μ F	2200 μ F	470 μ F	1000 μ F

NOTES
RECOMMENDED TEST AND APPLICATION CIRCUIT

1. TVS&FUSE be helpful with over voltage protection and inrush limiting. Recommended FUSE better be 1.5~2times of the rated current .
2. The input filter capacitor C6 could select the aluminum electrolytic capacitors or tantalum capacitors, and the withstand voltage should be greater than the highest input voltage. Recommended capacitor should be between 22 μ F~100 μ F.
3. C1,C2 for the input filter capacitor,0.1~1 μ F high-frequency ceramics capacitor or chip capacitor are recommended. The withstand voltage of output filter C5, C7 should be greater than the highest output voltage. Recommended capacitor of C7 better within 100 μ F and C5 connected with the chip to reduce the input voltage peak, recommended 0.1~1 μ F high-frequency ceramics capacitor or chip capacitor.