

DMV-15 SERIES, 15WATT, 2:1 INPUT RANGE

FEATURES:

- ✓ 2 year warranty
- ✓ Six-side shielded metal case
- ✓ Low ripple and noise
- ✓ Over current and short circuit protection
- ✓ Remote on/off
- ✓ Adjustable output voltage



Model	Input voltage (Vdc)	Output voltage (Vdc)	Output current (mA)	Efficiency Typ.
DMV15-1211	12(9~18)	5	3000	80%
DMV15-1212		9	1660	85%
DMV15-1213		12	1250	85%
DMV15-1214		15	1000	85%
DMV15-1215		24	625	85%
DMV15-1216		48	310	85%
DMV15-1221		±5	±1500	80%
DMV15-1222		±9	±830	85%
DMV15-1223		±12	±625	85%
DMV15-1224		±15	±500	85%
DMV15-1225		±24	±310	85%
DMV15-2411		24(18~36)	5	3000
DMV15-2412	9		1660	85%
DMV15-2413	12		1250	85%
DMV15-2414	15		1000	85%
DMV15-2415	24		625	85%
DMV15-2416	48		310	85%
DMV15-2421	±5		±1500	80%
DMV15-2422	±9		±830	85%
DMV15-2423	±12		±625	85%
DMV15-2424	±15		±500	85%
DMV15-2425	±24		±310	85%
DMV15-4811	48(36~72)		5	3000
DMV15-4812		9	1660	85%
DMV15-4813		12	1250	85%
DMV15-4814		15	1000	85%
DMV15-4815		24	625	85%
DMV15-4816		48	310	85%
DMV15-4821		±5	±1500	80%

DMV-15 SERIES, 15WATT, 2:1 INPUT RANGE

Model	Input voltage (Vdc)	Output voltage (Vdc)	Output current (mA)	Efficiency Typ.
DMV15-4822	48(36~72)	±9	±830	85%
DMV15-4823		±12	±625	85%
DMV15-4824		±15	±500	85%
DMV15-4825		±24	±310	85%
DMV15-11011	110(72~144)	5	3000	80%
DMV15-11012		9	1660	85%
DMV15-11013		12	1250	85%
DMV15-11014		15	1000	85%
DMV15-11015		24	625	85%
DMV15-11016		48	310	85%
DMV15-11021		±5	±1500	80%
DMV15-11022		±9	±830	85%
DMV15-11023		±12	±625	85%
DMV15-11024		±15	±500	85%
DMV15-11025		±24	±310	85%

Notes:

1. Other input and output models may available on request;
2. Above models are default to metal case.

ELECTRICAL

Input voltage range	12V	9-18Vdc
	24V	18-36Vdc
	48V	36-72Vdc
	110V	72-144Vdc
Remote control (Low level remote)	High level or vacant Low level or connect ground	Turn on Turn off
Output voltage accuracy	---	Vo1, Vo2: ±1%, ±3%
Output voltage adjustable	---	±10%
Line regulation	Nominal Load, full voltage	Vo1, Vo2: ±0.2%, ±1.5%
Load regulation	20% ~ 100% rated load	Vo1, Vo2: ±0.5%, ±4%
Dynamic response (transient/recovery time)	5%-50%-75% load capability	$\Delta V_{o1}/\Delta t$: ±4.0%/500 μ s
Ripple and noise	20MHz BM, full load	Vo \leq 5.0V, \leq 50mVp-p Vo \geq 48V, \leq 180mVp-p Other, \leq 100mVp-p
Isolation voltage (<2mA/min)	Input to output	1500Vdc
	Input to case	500Vdc

DMV-15 SERIES, 15WATT, 2:1 INPUT RANGE
ELECTRICAL

Switching frequency	300KHz	330KHz max.
Turn-on delay time	---	≤200ms
Operating temperature range	Free air	-25°C to +55°C
Storage temperature range	---	-45°C to +105°C
Input under voltage protection	When input voltage is lower than the low input voltage	Auto-recovery
Over current protection	---	Auto-recovery
Short circuit protection	---	Continuous auto-recovery
Cooling method	---	Cooling by air convection
Relative humidity	---	10%-90% max.
Weight	---	35.7g
MTBF	Bellcore TR-332, 25°C	2x10 ⁵ Hrs

Notes: Unless otherwise specified, all the parameters of the test conditions are as follows: ambient temperature 25°C, the nominal input voltage, pure resistive nominal load.

DMV-15 SERIES, 15WATT, 2:1 INPUT RANGE

MECHANICAL

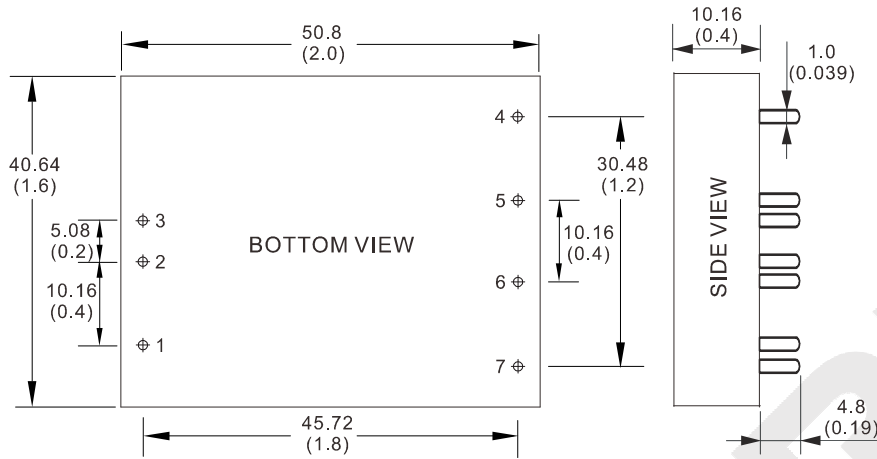

CONNECTION

PIN #	SINGLE	DUAL
1	REM	REM
2	-Vin	-Vin
3	+Vin	+Vin
4	No pin	+Vo1
5	+Vo	COM
6	GND	-Vo2
7	TRIM	TRIM

Note:

* Unit is mm(inch).

LAYOUT

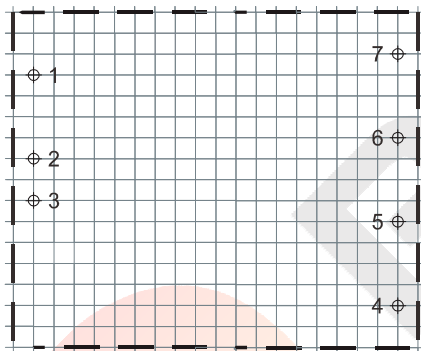

Unit: mm(inch)
PCB vertical view
Grid spacing: 2.54mm(0.1 inch)

TEMPERATURE PROFILE

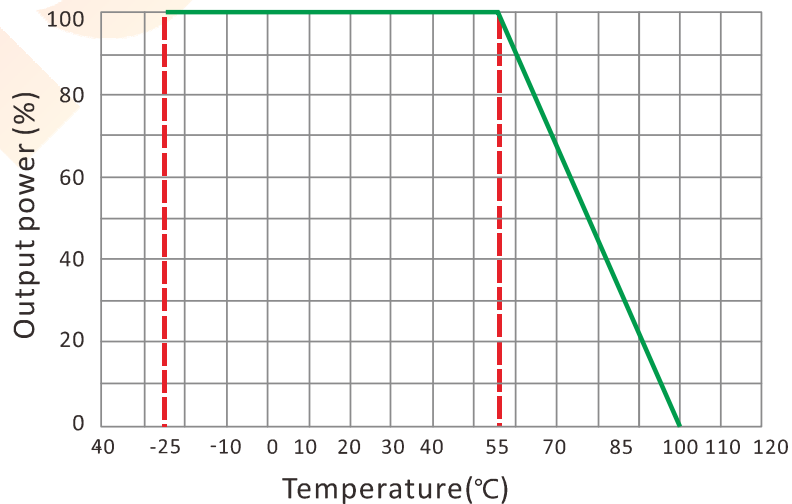

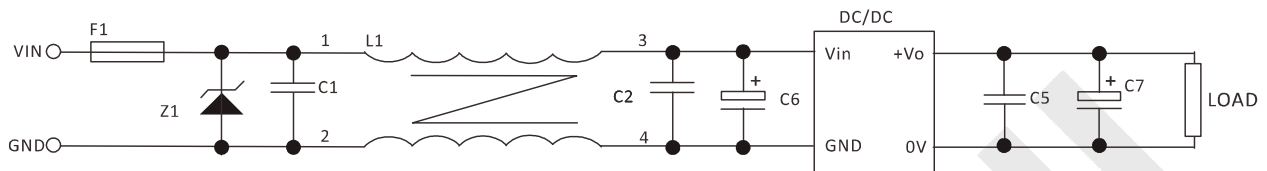
DMV-15 SERIES, 15WATT, 2:1 INPUT RANGE
NOTES
RECOMMENDED TEST AND APPLICATION CIRCUIT

1. TVS&FUSE be helpful with over voltage protection and inrush limiting. Recommended FUSE better be 1.5~2times of the rated current .
2. The input filter capacitor C6 could select the aluminum electrolytic capacitors or tantalum capacitors, and the withstand voltage should be greater than the highest input voltage. Recommended capacitor should be between 22 μ F~100 μ F.
3. C1,C2 for the input filter capacitor,0.1~1 μ F high-frequency ceramics capacitor or chip capacitor are recommended. The withstand voltage of output filter C5, C7 should be greater than the highest output voltage. Recommended capacitor of C7 better within 100 μ F and C5 connected with the chip to reduce the input voltage peak, recommended 0.1~1 μ F high-frequency ceramics capacitor or chip capacitor.