

SN54HCT620, SN54HCT623, SN74HCT620, SN74HCT623

Octal Bus Transceivers with 3-STATE Outputs

These octal bus transceivers are designed for asynchronous two-way communication between data buses. The control function implementation allows for maximum flexibility in timing. These devices allow data transmission from the A bus to the B bus or from the B bus to the A bus depending upon the logic levels at the enable inputs (GBA and GAB). The enable inputs can be used to disable the device so that the buses are effectively isolated.

Rochester Electronics Manufactured Components

Rochester branded components are manufactured using either die/wafers purchased from the original suppliers or Rochester wafers recreated from the original IP. All recreations are done with the approval of the OCM.

Parts are tested using original factory test programs or Rochester developed test solutions to guarantee product meets or exceeds the OCM data sheet.

Quality Overview

- ISO-9001
- AS9120 certification
- Qualified Manufacturers List (QML) MIL-PRF-38535
 - Class Q Military
 - Class V Space Level
- Qualified Suppliers List of Distributors (QSLD)
 - Rochester is a critical supplier to DLA and meets all industry and DLA standards.

Rochester Electronics, LLC is committed to supplying products that satisfy customer expectations for quality and are equal to those originally supplied by industry manufacturers.

The original manufacturer's datasheet accompanying this document reflects the performance and specifications of the Rochester manufactured version of this device. Rochester Electronics guarantees the performance of its semiconductor products to the original OEM specifications. 'Typical' values are for reference purposes only. Certain minimum or maximum ratings may be based on product characterization, design, simulation, or sample testing.

SN54HCT620, SN54HCT623, SN74HCT620, SN74HCT623 OCTAL BUS TRANSCEIVERS WITH 3-STATE OUTPUTS

D2804, MARCH 1984—REVISED SEPTEMBER 1987

- Inputs are TTL-Voltage Compatible
- Lock Bus-Latch Capability
- Choice of True or Inverting Logic
- High-Current 3-State Outputs Can Drive Up to 15 LSTTL Loads
- Package Options Include Plastic "Small Outline" Packages, Ceramic Chip Carriers, and Standard Plastic and Ceramic 300-mil DIPs
- Dependable Texas Instruments Quality and Reliability

DEVICE	LOGIC
'HCT620	Inverting
'HCT623	True

description

These octal bus transceivers are designed for asynchronous two-way communication between data buses. The control function implementation allows for maximum flexibility in timing.

These devices allow data transmission from the A bus to the B bus or from the B bus to the A bus depending upon the logic levels at the enable inputs ($\overline{\text{GBA}}$ and GAB.)

The enable inputs can be used to disable the device so that the buses are effectively isolated.

The dual-enable configuration gives these devices the capability to store data by simultaneous enabling of $\overline{\text{GBA}}$ and GAB. Each output reinforces its input in this transceiver configuration. Thus when both control inputs are enabled and all other data sources to the two sets of bus lines are at high impedance, both sets of bus lines (16 in all) will remain at their last states. The 8-bit codes appearing on the two sets of buses will be identical for the 'HCT623 or complementary for the 'HCT620.

The SN54HCT620 and SN54HCT623 are characterized for operation over the full military temperature range of -55°C to 125°C . The SN74HCT620 and SN74HCT623 are characterized for operation from -40°C to 85°C .

FUNCTION TABLE

ENABLE INPUTS		OPERATION	
$\overline{\text{GBA}}$	GAB	'HCT620	'HCT623
L	L	$\overline{\text{B}}$ data to A bus	B data to A bus
H	H	$\overline{\text{A}}$ data to B bus	A data to B bus
H	L	Isolation	Isolation
L	H	$\overline{\text{B}}$ data to A bus, $\overline{\text{A}}$ data to B bus	B data to A bus, A data to B bus

SN54HCT' . . . J PACKAGE
SN74HCT' . . . DW or N PACKAGE
(TOP VIEW)

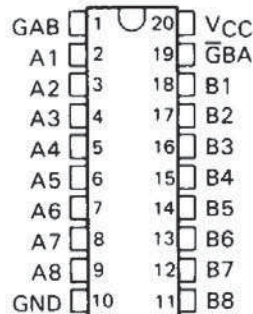

SN54HCT' . . . FK PACKAGE
(TOP VIEW)

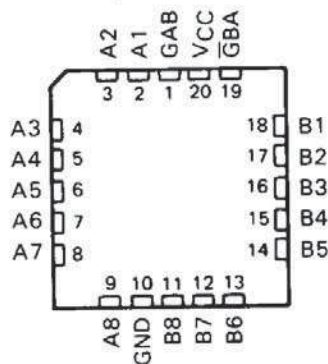

2

HCMOS Devices

SN54HCT620, SN54HCT623, SN74HCT620, SN74HCT620 OCTAL BUS TRANSCEIVERS WITH 3-STATE OUTPUTS

logic symbols†

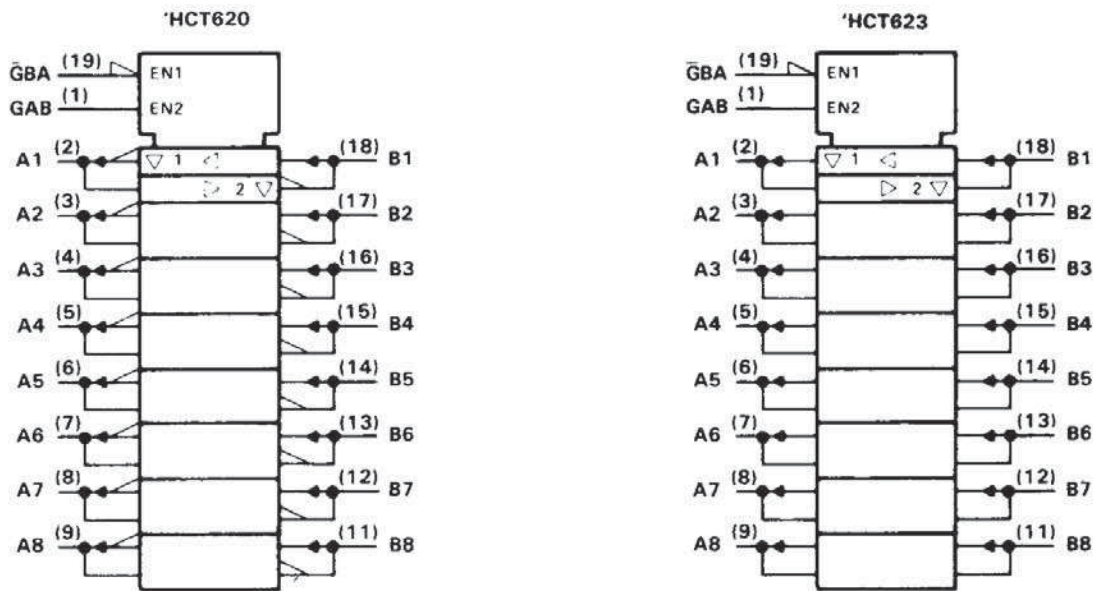

†These symbols are in accordance with ANSI/IEEE Std 91-1984 and IEC Publication 617-12.

logic diagrams (positive logic)

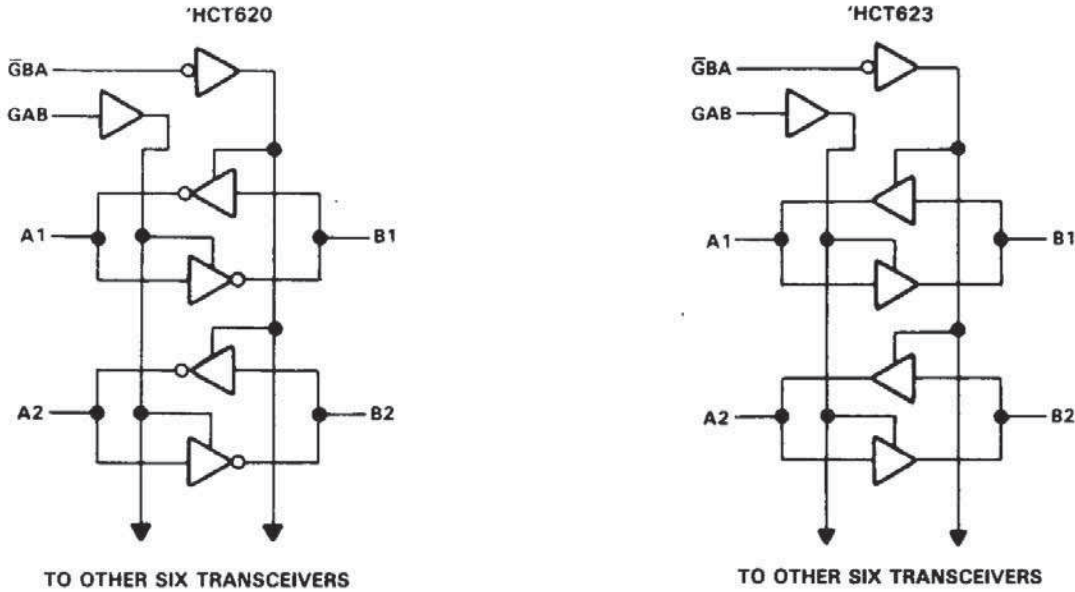

SN54HCT620, SN54HCT623, SN74HCT620, SN74HCT623 OCTAL BUS TRANSCEIVERS WITH 3-STATE OUTPUTS

absolute maximum ratings over operating free-air temperature range†

Supply voltage, V_{CC}	-0.5 V to 7 V
Input clamp current, I_{IK} ($V_I < 0$ or $V_I > V_{CC}$)	± 20 mA
Output clamp current, I_{OK} ($V_O < 0$ or $V_O > V_{CC}$)	± 20 mA
Continuous output current, I_O ($V_O = 0$ to V_{CC})	± 35 mA
Continuous current through V_{CC} or GND pins	± 70 mA
Lead temperature 1,6 mm (1/16 in) from case for 60 s: FK or J package	300°C
Lead temperature 1,6 mm (1/16 in) from case for 10 s: DW or N package	260°C
Storage temperature range	-65°C to 150°C

† Stresses beyond those listed under "absolute maximum ratings" may cause permanent damage to the device. These are stress ratings only, and functional operation of the device at these or any other conditions beyond those indicated under "recommended operating conditions" is not implied. Exposure to absolute-maximum-rated conditions for extended periods may affect device reliability.

recommended operating conditions

		SN54HCT620 SN54HCT623			SN74HCT620 SN74HCT623			UNIT
		MIN	NOM	MAX	MIN	NOM	MAX	
V_{CC}	Supply voltage	4.5	5	5.5	4.5	5	5.5	V
V_{IH}	High-level input voltage	$V_{CC} = 4.5$ V to 5.5 V			2			V
V_{IL}	Low-level input voltage	$V_{CC} = 4.5$ V to 5.5 V			0			V
V_I	Input voltage	0		V_{CC}	0		V_{CC}	V
V_O	Output voltage	0		V_{CC}	0		V_{CC}	V
t_t	Input transition (rise and fall) times	0			500			ns
T_A	Operating free-air temperature	-55			125			°C

electrical characteristics over recommended operating free-air temperature range (unless otherwise noted)

PARAMETER	TEST CONDITIONS	V_{CC}	$T_A = 25^\circ\text{C}$			SN54HCT620 SN54HCT623		SN74HCT620 SN74HCT623		UNIT
			MIN	TYP	MAX	MIN	MAX	MIN	MAX	
V_{OH}	$V_I = V_{IH}$ or V_{IL} , $I_{OH} = -20$ μA	4.5 V	4.4	4.499		4.4		4.4	V	
	$V_I = V_{IH}$ or V_{IL} , $I_{OH} = -6$ mA	4.5 V	3.98	4.30		3.7		3.84		
V_{OL}	$V_I = V_{IH}$ or V_{IL} , $I_{OL} = 20$ μA	4.5 V		0.001	0.1		0.1	0.1	V	
	$V_I = V_{IH}$ or V_{IL} , $I_{OL} = 6$ mA	4.5 V		0.17	0.26		0.4	0.33		
I_I	GAB or $\bar{G}BA$, $V_I = V_{CC}$ or 0	5.5 V		± 0.1	± 100		± 1000	± 1000	nA	
I_{OZ}	A or B, $V_I = V_{CC}$ or GND	5.5 V		± 0.01	± 0.5		± 10	± 5	μA	
I_{CC}	$V_I = V_{CC}$ or 0, $I_O = 0$	5.5 V			8		160	80	μA	
ΔI_{CC}^\ddagger	One input at 0.5 V or 2.4 V Other inputs at 0 V or V_{CC}	5.5 V		1.4	2.4		3.0	2.9	mA	
C_i	GAB or $\bar{G}BA$	4.5 to 5.5 V		3	10		10	10	pF	

‡ This is the increase in supply current for each input that is at one of the specified TTL voltage levels rather than 0 V or V_{CC} .

2

HCMOS Devices

**SN54HCT620, SN54HCT623, SN74HCT620, SN74HCT623
OCTAL BUS TRANSCEIVERS WITH 3-STATE OUTPUTS**

switching characteristics over recommended operating free-air temperature range (unless otherwise noted), $C_L = 50 \text{ pF}$ (see Note 1)

PARAMETER	FROM (INPUT)	TO (OUTPUT)	V _{CC}	T _A = 25°C			SN54HCT620 SN54HCT623		SN74HCT620 SN74HCT623		UNIT
				MIN	TYP	MAX	MIN	MAX	MIN	MAX	
t _{pd}	A or B	B or A	4.5 V	15	22		33		28	ns	
			5.5 V	13	20		30		25		
t _{en}	$\overline{\text{G}}\text{BA}$	A	4.5 V	30	42		63		53	ns	
			5.5 V	23	38		57		48		
t _{dis}	$\overline{\text{G}}\text{BA}$	A	4.5 V	18	30		45		38	ns	
			5.5 V	16	28		42		35		
t _{en}	GAB	B	4.5 V	30	42		63		53	ns	
			5.5 V	23	38		57		48		
t _{dis}	GAB	B	4.5 V	18	30		45		38	ns	
			5.5 V	16	28		42		35		
t _t		A or B	4.5 V	9	12		18		15	ns	
			5.5 V	8	11		16		14		

C _{pd}	Power dissipation capacitance per transceiver	No load, T _A = 25°C	40 pF typ
-----------------	---	--------------------------------	-----------

switching characteristics over recommended operating free-air temperature range (unless otherwise noted), $C_L = 150 \text{ pF}$ (see Note 1)

PARAMETER	FROM (INPUT)	TO (OUTPUT)	V _{CC}	T _A = 25°C			SN54HCT620 SN54HCT623		SN74HCT620 SN74HCT623		UNIT
				MIN	TYP	MAX	MIN	MAX	MIN	MAX	
t _{pd}	A or B	B or A	4.5 V	18	38		58		47	ns	
			5.5 V	11	34		52		42		
t _{en}	$\overline{\text{G}}\text{BA}$	A	4.5 V	36	59		89		74	ns	
			5.5 V	30	53		80		67		
t _{en}	GAB	B	4.5 V	36	59		89		74	ns	
			5.5 V	30	53		80		67		
t _t		A or B	4.5 V	17	42		63		53	ns	
			5.5 V	14	38		57		48		

NOTE 1: Load circuits and voltage waveforms are shown in Section 1.