

## **SN54HC658, SN54HC659, SN74HC658, SN74HC658**

### *Octal Bus Transceivers with Parity*

These octal bus transceivers are designed for asynchronous, bidirectional communication between data buses. The devices transmit data from the A Bus to the B bus or from the B Bus to the A Bus, depending on the level at the direction control inputs, GAB and  $\overline{\text{GBA}}$ . These devices also generate parity outputs, APO and BPO, which reflect the number of high levels at the A Bus and B Bus, respectively, taking into account the parity inputs API and BPI.

The bidirectional I/O ports feature active circuitry on the input stage that, when the output shared by that pin is disabled, will maintain the input in the last state taken by the output. This state will be maintained until changed by activity on the bus. The advantage of this arrangement is that when all outputs on the bus are disabled, the inputs will be prevented from floating, resulting in minimum power dissipation and minimum susceptibility to noise. This eliminates any need for external pull-up or pull-down resistors. The parity inputs API and BPI have similar circuits.

---

### **Rochester Electronics Manufactured Components**

Rochester branded components are manufactured using either die/wafers purchased from the original suppliers or Rochester wafers recreated from the original IP. All recreations are done with the approval of the OCM.

Parts are tested using original factory test programs or Rochester developed test solutions to guarantee product meets or exceeds the OCM data sheet.

### **Quality Overview**

- ISO-9001
- AS9120 certification
- Qualified Manufacturers List (QML) MIL-PRF-38535
  - Class Q Military
  - Class V Space Level
- Qualified Suppliers List of Distributors (QSLD)
  - Rochester is a critical supplier to DLA and meets all industry and DLA standards.

Rochester Electronics, LLC is committed to supplying products that satisfy customer expectations for quality and are equal to those originally supplied by industry manufacturers.

---

*The original manufacturer's datasheet accompanying this document reflects the performance and specifications of the Rochester manufactured version of this device. Rochester Electronics guarantees the performance of its semiconductor products to the original OEM specifications. 'Typical' values are for reference purposes only. Certain minimum or maximum ratings may be based on product characterization, design, simulation, or sample testing.*

# SN54HC658, SN54HC659, SN74HC658, SN74HC659 OCTAL BUS TRANSCEIVERS WITH PARITY

D2839, MARCH 1984—REVISED SEPTEMBER 1987

- Bus Transceivers with Inverting Outputs ('HC658) or True Outputs ('HC659)
- Generates a Parity Bit for A Bus and B Bus
- Easily Cascadable
- Internal Active Pull-Ups and Pull-Downs
- High-Current 3-State Outputs Can Drive Up to 15 LSTTL Loads
- Package Options Include Plastic "Small Outline" Packages, Ceramic Chip Carriers, and Standard Plastic and Ceramic 300-mil DIPs
- Dependable Texas Instruments Quality and Reliability

SN54HC658, SN54HC659 . . . . . 16T PACKAGE  
SN74HC658, SN74HC659 . . . . . DW OR NT PACKAGE  
(TOP VIEW)

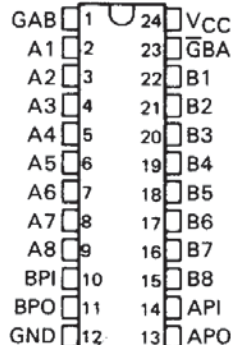

SN54HC658, SN54HC659 . . . . . FK PACKAGE  
(TOP VIEW)

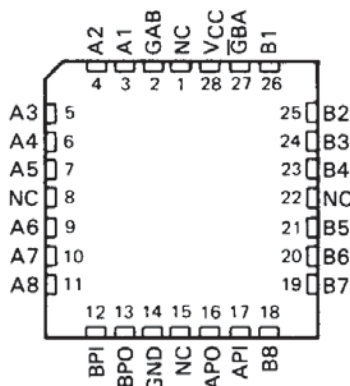

NC—No internal connection

## description

These octal bus transceivers are designed for asynchronous, bidirectional communication between data buses. The devices transmit data from the A Bus to the B Bus or from the B Bus to the A Bus, depending on the level at the direction control inputs, GAB and  $\bar{G}BA$ . These devices also generate parity outputs, APO and BPO, which reflect the number of high levels at the A Bus and B Bus, respectively, taking into account the parity inputs API and BPI.

The bidirectional I/O ports feature active circuitry on the input stage that, when the output shared by that pin is disabled, will maintain the input in the last state taken by the output. This state will be maintained until changed by activity on the bus. The advantage of this arrangement is that when all outputs on the bus are disabled, the inputs will be prevented from floating, resulting in minimum power dissipation and minimum susceptibility to noise. This eliminates any need for external pull-up or pull-down resistors. The parity inputs API and BPI have similar circuits. For further information, see Typical Application Data.

The SN54HC658 and SN54HC659 are characterized for operation over the full military temperature range of  $-55^{\circ}\text{C}$  to  $125^{\circ}\text{C}$ . The SN74HC658 and SN74HC659 are characterized for operation from  $-40^{\circ}\text{C}$  to  $85^{\circ}\text{C}$ .

2

HC MOS Devices

PRODUCTION DATA documents contain information current as of publication date. Products conform to specifications per the terms of Texas Instruments standard warranty. Production processing does not necessarily include testing of all parameters.

TEXAS  
INSTRUMENTS

POST OFFICE BOX 655012 • DALLAS, TEXAS 75265

Copyright © 1984, Texas Instruments Incorporated

2-599

# SN54HC658, SN54HC659, SN74HC658, SN74HC659 OCTAL BUS TRANSCEIVERS WITH PARITY

FUNCTION TABLE

CONTROL INPUTS		NUMBER OF HIGH INPUTS ON A BUS AND API	NUMBER OF HIGH INPUTS ON B BUS AND BPI	OUTPUTS		OPERATION	
$\bar{G}BA$	GAB			APO	BPO	'HC658	'HC659
L	L	X	0, 2, 4, 6, 8	Z	H	$\bar{B}$ Data to A Bus	B Data to A Bus
		X	1, 3, 5, 7, 9	Z	L		
H	H	0, 2, 4, 6, 8	X	H	Z	$\bar{A}$ Data to B Bus	A Data to B Bus
		1, 3, 5, 7, 9	X	L	Z		
H	L	X	X	Z	Z	Isolation	Isolation
L	H	X	0, 2, 4, 6, 8		H	$\bar{B}$ Data to A Bus, $\bar{A}$ Data to B Bus	B Data to A Bus, A Data to B Bus
		X	1, 3, 5, 7, 9		L		
		0, 2, 4, 6, 8	X	H			
		1, 3, 5, 7, 9	X	L			

2

HC MOS Devices

logic symbols†

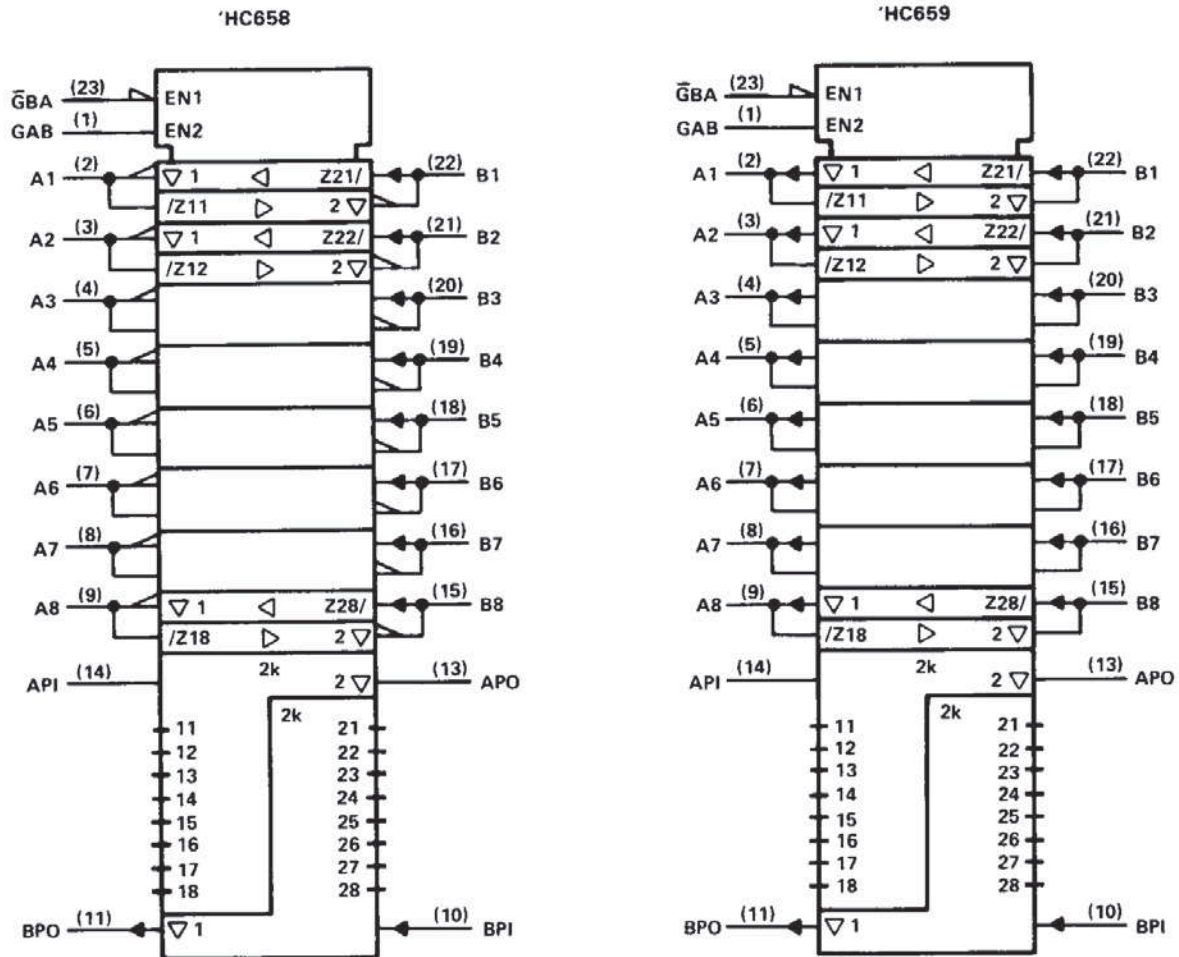

†These symbols are in accordance with ANSI/IEEE Std 91-1984 and IEC Publication 617-12. Pin numbers shown are for DW, JT, and NT packages.

**SN54HC658, SN54HC659, SN74HC658, SN74HC659  
OCTAL BUS TRANSCEIVERS WITH PARITY**

logic diagram (positive logic)

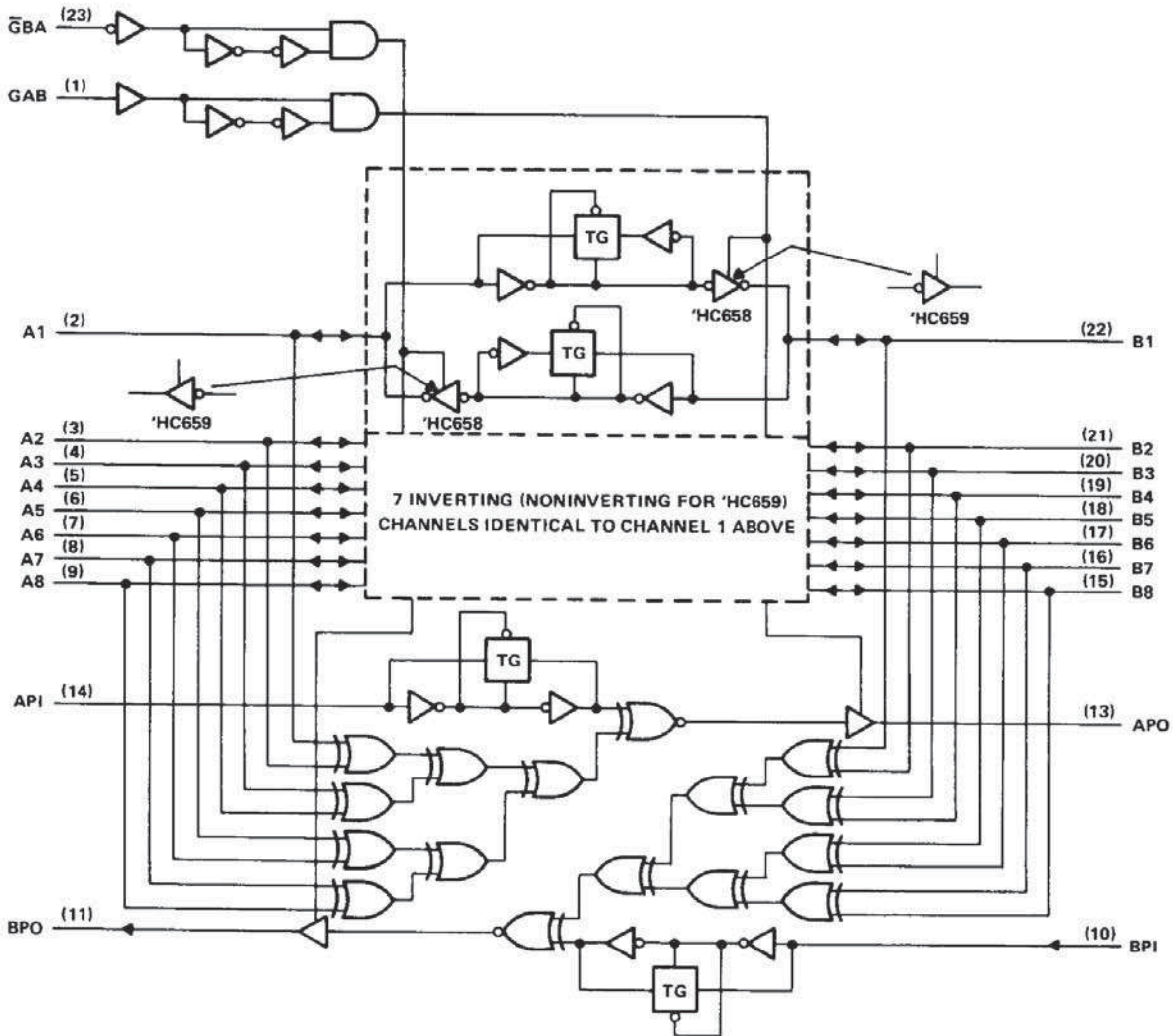

Pin numbers shown are for DW, JT, and NT packages.

**absolute maximum ratings over operating free-air temperature range†**

Supply voltage, $V_{CC}$ .....	-0.5 V to 7 V
Input clamp current, $I_{IK}$ ( $V_I < 0$ or $V_I > V_{CC}$ ) .....	$\pm 20$ mA
Output clamp current, $I_{OK}$ ( $V_O < 0$ or $V_O > V_{CC}$ ) .....	$\pm 20$ mA
Continuous output current, $I_O$ ( $V_O = 0$ to $V_{CC}$ ) .....	$\pm 35$ mA
Continuous current through $V_{CC}$ or GND pins .....	$\pm 70$ mA
Lead temperature 1,6 mm (1/16 in) from case for 60 s: FK or JT package .....	300 °C
Lead temperature 1,6 mm (1/16 in) from case for 10 s: DW or NT package .....	260 °C
Storage temperature range .....	-65 °C to 150 °C

† Stresses beyond those listed under "absolute maximum ratings" may cause permanent damage to the device. These are stress ratings only, and functional operation of the device at these or any other conditions beyond those indicated under "recommended operating conditions" is not implied. Exposure to absolute-maximum-rated conditions for extended periods may affect device reliability.

**SN54HC658, SN54HC659, SN74HC658, SN74HC659**  
**OCTAL BUS TRANSCEIVERS WITH PARITY**

**2**

**HCMOS Devices**

**recommended operating conditions**

		SN54HC658 SN54HC659			SN74HC658 SN74HC659			UNIT
		MIN	NOM	MAX	MIN	NOM	MAX	
V <sub>CC</sub>	Supply voltage	2	5	6	2	5	6	V
V <sub>IH</sub>	High-level input voltage	V <sub>CC</sub> = 2 V V <sub>CC</sub> = 4.5 V V <sub>CC</sub> = 6 V		1.5 3.15 4.2	1.5 3.15 4.2			V
V <sub>IL</sub>	Low-level input voltage	V <sub>CC</sub> = 2 V V <sub>CC</sub> = 4.5 V V <sub>CC</sub> = 6 V		0 0 0	0.3 0.9 1.2		0 0.3 0.9 1.2	V
V <sub>I</sub>	Input voltage			0	V <sub>CC</sub>			V
V <sub>O</sub>	Output voltage			0	V <sub>CC</sub>			V
t <sub>t</sub>	Input transition (rise and fall) times	V <sub>CC</sub> = 2 V V <sub>CC</sub> = 4.5 V V <sub>CC</sub> = 6 V		0 0 0	1000 500 400		0 500 400	ns
T <sub>A</sub>	Operating free-air temperature			-55	125		-40 85	°C

**electrical characteristics over recommended operating free-air temperature range (unless otherwise noted)**

PARAMETER	TEST CONDITIONS	V <sub>CC</sub>	T <sub>A</sub> = 25 °C			SN54HC658 SN54HC659		SN74HC658 SN74HC659		UNIT	
			MIN	TYP	MAX	MIN	MAX	MIN	MAX		
V <sub>OH</sub>	V <sub>I</sub> = V <sub>IH</sub> or V <sub>IL</sub> . I <sub>OH</sub> = -20 μA	2 V	1.9	1.998		1.9		1.9	V		
		4.5 V	4.4	4.499		4.4		4.4			
		6 V	5.9	5.999		5.9		5.9			
V <sub>OH</sub>	All outputs except APO & BPO	V <sub>I</sub> = V <sub>IH</sub> or V <sub>IL</sub> . I <sub>OH</sub> = -6 mA	4.5 V	3.98	4.30		3.7		3.84		
		V <sub>I</sub> = V <sub>IH</sub> or V <sub>IL</sub> . I <sub>OH</sub> = -7.8 mA	6 V	5.48	5.80		5.2		5.34		
	APO or BPO	V <sub>I</sub> = V <sub>IH</sub> or V <sub>IL</sub> . I <sub>OH</sub> = -4 mA	4.5 V	3.98	4.30		3.7		3.84		
		V <sub>I</sub> = V <sub>IH</sub> or V <sub>IL</sub> . I <sub>OH</sub> = -5.2 mA	6 V	5.48	5.80		5.2		5.34		
V <sub>OL</sub>	V <sub>I</sub> = V <sub>IH</sub> or V <sub>IL</sub> . I <sub>OL</sub> = 20 μA	2 V		0.002	0.1		0.1		0.1		
		4.5 V		0.001	0.1		0.1		0.1		
		6 V		0.001	0.1		0.1		0.1		
V <sub>OL</sub>	All outputs except APO & BPO	V <sub>I</sub> = V <sub>IH</sub> or V <sub>IL</sub> . I <sub>OL</sub> = 6 mA	4.5 V		0.17	0.26		0.4		0.33	
		V <sub>I</sub> = V <sub>IH</sub> or V <sub>IL</sub> . I <sub>OL</sub> = 7.8 mA	6 V		0.15	0.26		0.4		0.33	
	APO or BPO	V <sub>I</sub> = V <sub>IH</sub> or V <sub>IL</sub> . I <sub>OL</sub> = 4 mA	4.5 V		0.17	0.26		0.4		0.33	
		V <sub>I</sub> = V <sub>IH</sub> or V <sub>IL</sub> . I <sub>OL</sub> = 5.2 mA	6 V		0.15	0.26		0.4		0.33	
I <sub>I</sub>	GAB, $\overline{\text{G}}\text{BA}$ , API or BPI	V <sub>I</sub> = V <sub>CC</sub> or 0	6 V		±0.1	±100		±1000		±1000	nA
I <sub>OZ</sub>	A or B	V <sub>O</sub> = V <sub>CC</sub> or 0	6 V		±0.01	±0.5		±10		±5	μA
I <sub>CC</sub>		V <sub>I</sub> = V <sub>CC</sub> or 0, I <sub>O</sub> = 0	6 V			8		160		80	μA
C <sub>i</sub> <sup>†</sup>		2 to 6 V			3	10		10		10	pF

<sup>†</sup>This parameter, C<sub>i</sub>, does not apply to transceiver I/O ports.

**SN54HC658, SN74HC658**  
**OCTAL BUS TRANSCEIVERS WITH PARITY**

switching characteristics over recommended operating free-air temperature range (unless otherwise noted),  $C_L = 50$  pF (see Note 1)

PARAMETER	FROM (INPUT)	TO (OUTPUT)	V <sub>CC</sub>	T <sub>A</sub> = 25°C			SN54HC658		SN74HC658		UNIT
				MIN	TYP	MAX	MIN	MAX	MIN	MAX	
t <sub>pd</sub>	A or B	B or A	2 V		75	150		225		190	ns
			4.5 V		15	30		45		38	
			6 V		13	26		38		32	
t <sub>pd</sub>	A or B	APO or BPO	2 V		115	230		345		290	ns
			4.5 V		23	46		69		58	
			6 V		20	39		59		49	
t <sub>pd</sub>	API or BPI	APO or BPO	2 V		77	155		235		195	ns
			4.5 V		15	31		47		39	
			6 V		13	26		40		33	
t <sub>en</sub>	GAB or $\overline{\text{G}}\text{BA}$	APO or BPO	2 V		117	235		355		295	ns
			4.5 V		23	47		71		59	
			6 V		20	40		60		50	
t <sub>dis</sub>	GAB or $\overline{\text{G}}\text{BA}$	APO or BPO	2 V		117	235		355		295	ns
			4.5 V		23	47		71		59	
			6 V		20	40		60		50	
t <sub>t</sub>		Any	2 V		28	60		90		75	ns
			4.5 V		8	12		18		15	
			6 V		6	10		15		13	

C <sub>pd</sub>	Power dissipation capacitance	No load, T <sub>A</sub> = 25°C	56 pF typ
-----------------	-------------------------------	--------------------------------	-----------

switching characteristics over recommended operating free-air temperature range (unless otherwise noted),  $C_L = 150$  pF (see Note 1)

PARAMETER	FROM (INPUT)	TO (OUTPUT)	V <sub>CC</sub>	T <sub>A</sub> = 25°C			SN54HC658		SN74HC658		UNIT
				MIN	TYP	MAX	MIN	MAX	MIN	MAX	
t <sub>pd</sub>	A or B	B or A	2 V		117	235		355		295	ns
			4.5 V		23	47		71		59	
			6 V		20	41		60		51	
t <sub>pd</sub>	A or B	APO or BPO	2 V		157	315		475		395	ns
			4.5 V		31	63		95		79	
			6 V		27	54		81		68	
t <sub>pd</sub>	API or BPI	APO or BPO	2 V		120	240		365		300	ns
			4.5 V		24	48		73		60	
			6 V		20	41		62		52	
t <sub>en</sub>	GAB or $\overline{\text{G}}\text{BA}$	APO or BPO	2 V		160	320		485		400	ns
			4.5 V		32	64		97		80	
			6 V		27	55		82		69	
t <sub>t</sub>		Any	2 V		37	210		315		265	ns
			4.5 V		12	42		63		53	
			6 V		10	36		53		45	

NOTE 1: Load circuits and voltage waveforms are shown in Section 1.

**SN54HC659, SN74HC659**  
**OCTAL BUS TRANSCEIVERS WITH PARITY**

**2** HCMOS Devices

switching characteristics over recommended operating free-air temperature range (unless otherwise noted),  $C_L = 50$  pF (see Note 1)

PARAMETER	FROM (INPUT)	TO (OUTPUT)	V <sub>CC</sub>	T <sub>A</sub> = 25°C			SN54HC659		SN74HC659		UNIT
				MIN	TYP	MAX	MIN	MAX	MIN	MAX	
t <sub>pd</sub>	A or B	B or A	2 V		70	140		210		175	ns
			4.5 V		14	28		42		35	
			6 V		12	24		36		30	
t <sub>pd</sub>	A or B	APO or BPO	2 V		115	230		345		290	ns
			4.5 V		23	46		69		58	
			6 V		20	39		59		49	
t <sub>pd</sub>	API or BPI	APO or BPO	2 V		77	155		235		195	ns
			4.5 V		15	31		47		39	
			6 V		13	26		40		33	
t <sub>en</sub>	GAB or $\overline{\text{GBA}}$	APO or BPO	2 V		117	235		355		295	ns
			4.5 V		23	47		71		59	
			6 V		20	40		60		50	
t <sub>dis</sub>	GAB or $\overline{\text{GBA}}$	APO or BPO	2 V		117	235		355		295	ns
			4.5 V		23	47		71		59	
			6 V		20	40		60		50	
t <sub>t</sub>		Any	2 V		28	60		90		75	ns
			4.5 V		8	12		18		15	
			6 V		6	10		15		13	

C <sub>pd</sub>	Power dissipation capacitance	No load, T <sub>A</sub> = 25°C	56 pF typ
-----------------	-------------------------------	--------------------------------	-----------

switching characteristics over recommended operating free-air temperature range (unless otherwise noted),  $C_L = 150$  pF (see Note 1)

PARAMETER	FROM (INPUT)	TO (OUTPUT)	V <sub>CC</sub>	T <sub>A</sub> = 25°C			SN54HC659		SN74HC659		UNIT
				MIN	TYP	MAX	MIN	MAX	MIN	MAX	
t <sub>pd</sub>	A or B	B or A	2 V		117	225		340		280	ns
			4.5 V		23	45		68		56	
			6 V		20	39		58		49	
t <sub>pd</sub>	A or B	APO or BPO	2 V		157	315		475		395	ns
			4.5 V		31	63		95		79	
			6 V		27	54		81		68	
t <sub>pd</sub>	API or BPI	APO or BPO	2 V		120	240		365		300	ns
			4.5 V		24	48		73		60	
			6 V		20	41		62		52	
t <sub>en</sub>	GAB or $\overline{\text{GBA}}$	APO or BPO	2 V		160	320		485		400	ns
			4.5 V		32	64		97		80	
			6 V		27	55		82		69	
t <sub>t</sub>		Any	2 V		37	210		315		265	ns
			4.5 V		12	42		63		53	
			6 V		10	36		53		45	

NOTE 1: Load circuits and voltage waveforms are shown in Section 1.

TYPICAL APPLICATION DATA

The unique structure used on the I/O ports and the parity inputs of these devices deserves some special consideration (see Figure 1). Only the input structure is shown. The conventional 3-state output structure associated with each I/O port has been omitted to facilitate understanding.

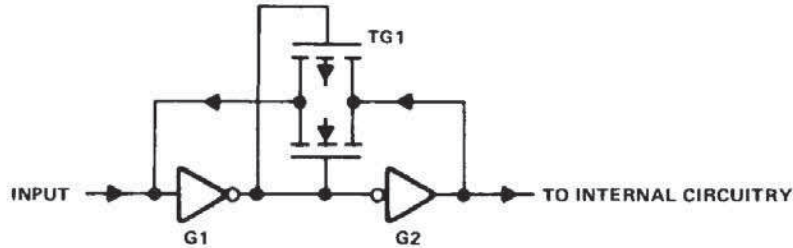

FIGURE 1: INPUT STRUCTURE

The two inverters (G1 and G2) have a transmission gate (TG1) connected in a feedback loop around them. This transmission gate is connected in an unusual fashion, that is, with the gates of both transistors connected to the output of G1. Thus, with the output of G1 at either a high or a low level, one or the other of the transistors will be turned on allowing feedback of the output of G2 to the input of G1. The effect of TG1 is that the input level will be maintained at whatever level existed prior to the bus being disabled or the level currently existing on the bus will be reinforced.

To understand the operation of this input, assume that initially the input is at a low logic level. As the input voltage is raised, TG1 sinks current to attempt to maintain the low level. However, TG1 consists of small geometry transistors and appears resistive as current flows thus allowing the input voltage to rise toward the threshold voltage of G1. When the threshold voltage is reached, G1 changes state causing G2 to change state. G2 then attempts to maintain a high level on the input through TG1. A similar operation occurs when the input voltage is decreased toward the threshold voltage of G1. G2 sources current through TG1 until the threshold is reached.

This characteristic of the input stage has some implications for the input current levels. With the input held at either  $V_{CC}$  or GND, there is no voltage across TG1 and negligible input current. However, as the input voltage is raised from GND or lowered from  $V_{CC}$ , the input current rises as the voltage across TG1 increases. The input current continues to rise until it reaches a maximum just as the threshold voltage of G1 is reached.

This configuration provides for minimum power dissipation when the bus is inactive (all outputs on the bus in the high-impedance state) and minimum susceptibility to noise on the bus during this time. The increase in input current may go unnoticed as it only occurs during transitions on the bus. Care must be taken when measuring input currents (e.g., at incoming inspection) to ensure that the input voltage is set to the correct value.

The use of these devices for interfacing to 8-, 16-, and 24-bit-wide memory arrays with parity is illustrated in Figures 2, 3 and 4.

**SN54HC658, SN54HC659, SN74HC658, SN74HC659**  
**OCTAL BUS TRANSCEIVERS WITH PARITY**

**TYPICAL APPLICATION DATA**

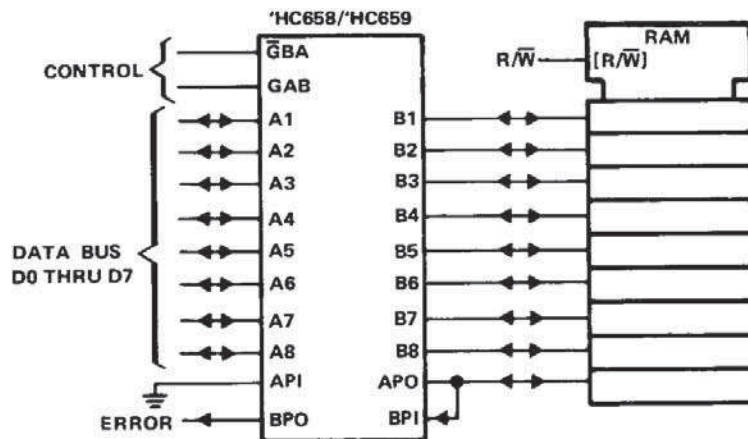

**FIGURE 2. 8-BIT-WIDE MEMORY ARRAY WITH PARITY**

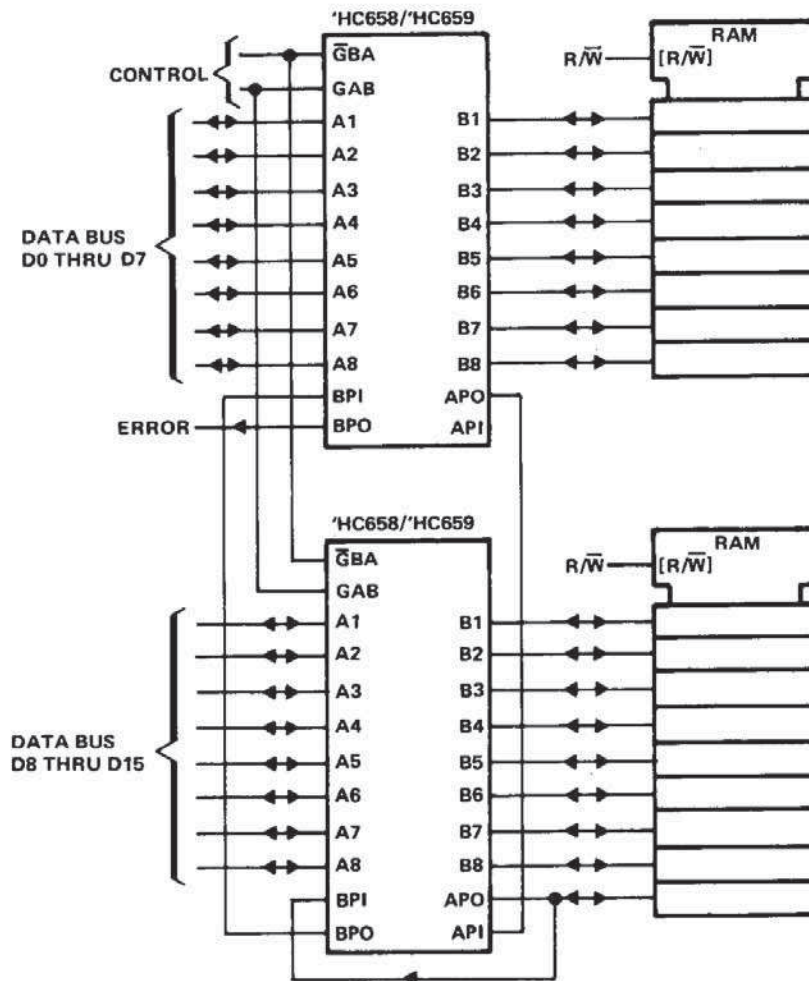

**FIGURE 3. 16-BIT-WIDE MEMORY ARRAY WITH PARITY**

TYPICAL APPLICATION DATA

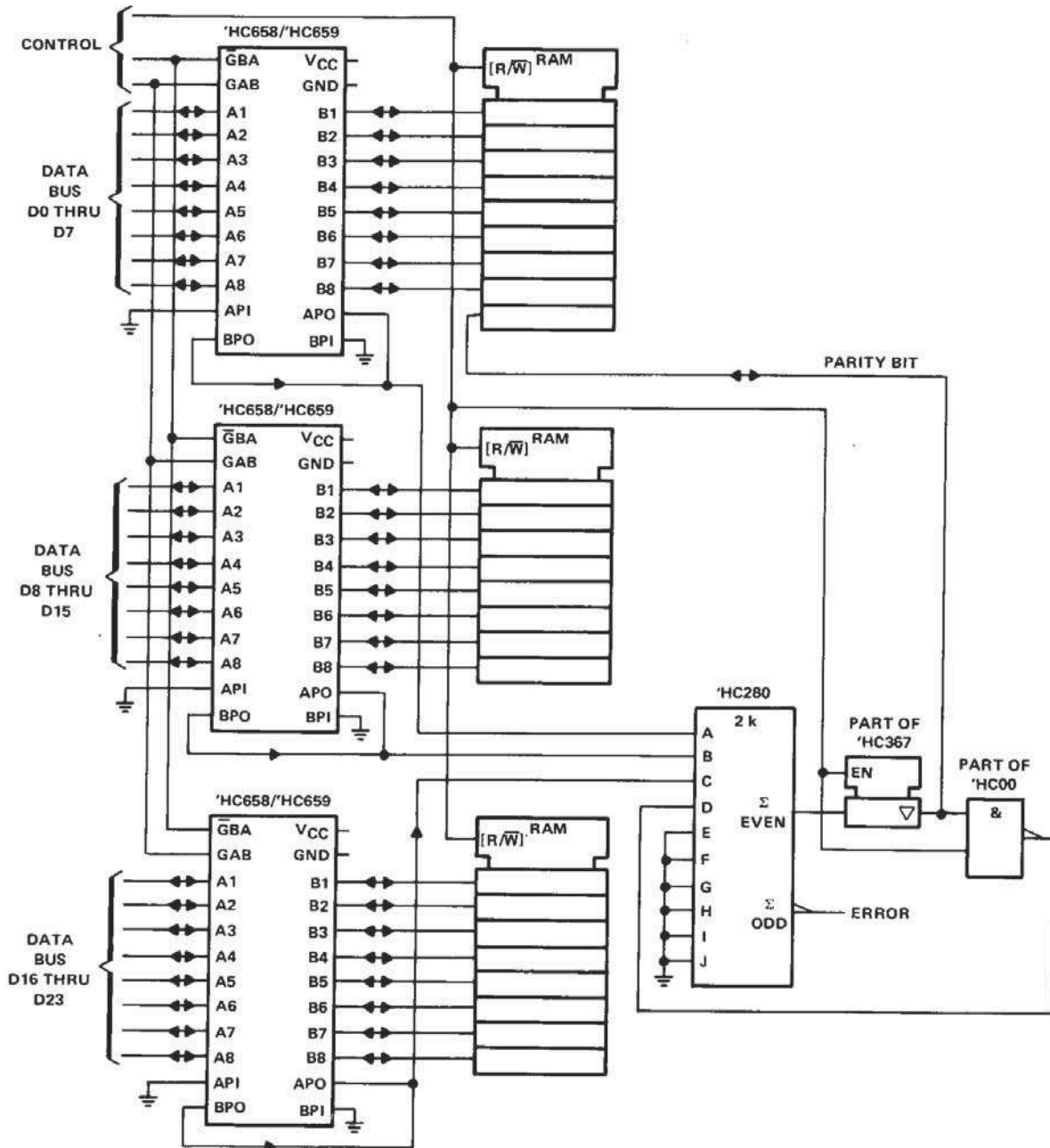

FIGURE 4. 24-BIT-WIDE MEMORY ARRAY WITH PARITY

NOTE: The 'HC280 eliminates ripple carry delays associated with Figures 2 and 3. However, in those two cases the delays are probably too small to be of concern.