

SN54ALS242B, SN54ALS243A, SN54AS242, SN54AS243 SN74ALS242B, SN74ALS243A, SN74AS242, SN74AS243

Quadruple Bus Transceivers with 3-State Outputs

These quadruple bus transceivers are designed for asynchronous two-way communications between data buses. The control function implementation allows for maximum flexibility in timing. These devices allow data transmission from the A bus to the B bus or from the B bus to the A bus depending upon the logic levels at the enable inputs (GBA and GAB). The enable inputs can be used to disable the device so that the buses are effectively isolated.

The dual-enable configuration gives the quadruple bus transceivers the capability to store data by simultaneous enabling of GBA and GAB. Each output reinforces its input in this transceiver configuration. Thus, when both control inputs are enabled and all other data sources to the two sets of bus lines are at high impedance, both sets of bus lines (8 in all) will retain their states. The 4-bit codes appearing on the two sets of buses will be complimentary for the 'ALS242 and 'AS242 or identical for the 'ALS243 and 'AS243.

Rochester Electronics Manufactured Components

Rochester branded components are manufactured using either die/wafers purchased from the original suppliers or Rochester wafers recreated from the original IP. All recreations are done with the approval of the OCM.

Parts are tested using original factory test programs or Rochester developed test solutions to guarantee product meets or exceeds the OCM data sheet.

Quality Overview

- ISO-9001
- AS9120 certification
- Qualified Manufacturers List (QML) MIL-PRF-38535
 - Class Q Military
 - Class V Space Level
- Qualified Suppliers List of Distributors (QSLD)
 - Rochester is a critical supplier to DLA and meets all industry and DLA standards.

Rochester Electronics, LLC is committed to supplying products that satisfy customer expectations for quality and are equal to those originally supplied by industry manufacturers.

The original manufacturer's datasheet accompanying this document reflects the performance and specifications of the Rochester manufactured version of this device. Rochester Electronics guarantees the performance of its semiconductor products to the original OEM specifications. 'Typical' values are for reference purposes only. Certain minimum or maximum ratings may be based on product characterization, design, simulation, or sample testing.

SN54ALS242B, SN54ALS243A, SN54AS242, SN54AS243 SN74ALS242B, SN74ALS243A, SN74AS242, SN74AS243 QUADRUPLE BUS TRANSCEIVERS WITH 3-STATE OUTPUTS

D2661, DECEMBER 1982—REVISED MAY 1986

- 2-Way Asynchronous Communication Between Data Buses
- P-N-P Inputs Reduce Loading
- Package Options Include Plastic "Small Outline" Packages, Ceramic Chip Carriers, and Standard Plastic and Ceramic 300-mil DIPs
- Dependable Texas Instruments Quality and Reliability

description

These quadruple bus transceivers are designed for asynchronous two-way communications between data buses. The control function implementation allows for maximum flexibility in timing. These devices allow data transmission from the A bus to the B bus or from the B bus to the A bus depending upon the logic levels at the enable inputs (GBA and $\bar{G}AB$). The enable inputs can be used to disable the device so that the buses are effectively isolated.

The dual-enable configuration gives the quadruple bus transceivers the capability to store data by simultaneous enabling of GBA and $\bar{G}AB$. Each output reinforces its input in this transceiver configuration. Thus, when both control inputs are enabled and all other data sources to the two sets of bus lines are at high impedance, both sets of bus lines (8 in all) will retain their states. The 4-bit codes appearing on the two sets of buses will be complimentary for the 'ALS242 and 'AS242 or identical for the 'ALS243 and 'AS243.

The -1 versions of the SN74ALS' parts are identical to the standard versions except that the recommended maximum I_{OL} is increased to 48 milliamperes. There are no -1 versions of the SN54ALS' parts.

The SN54' family is characterized for operation over the full military temperature range of -55°C to 125°C . The SN74' family is characterized for operation from 0°C to 70°C .

SN54' . . . J PACKAGE
SN74' . . . D OR N PACKAGE
(TOP VIEW)

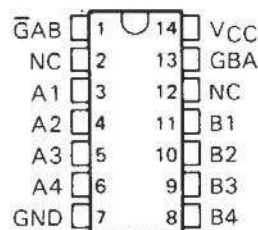

SN54' . . . FK PACKAGE
(TOP VIEW)

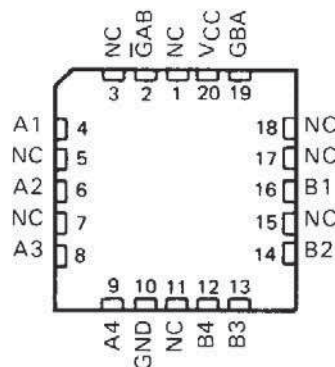

NC—No internal connection

FUNCTION TABLE

INPUTS		'ALS242B	'ALS243A
$\bar{G}AB$	GBA	'AS242	'AS243
L	L	\bar{A} to B	A to B
H	H	\bar{B} to A	B to A
H	L	Isolation	Isolation
L	H	Latch A and B ($A = \bar{B}$)	Latch A and B ($A = B$)

PRODUCTION DATA documents contain information current as of publication date. Products conform to specifications per the terms of Texas Instruments standard warranty. Production processing does not necessarily include testing of all parameters.

TEXAS
INSTRUMENTS

POST OFFICE BOX 655012 • DALLAS, TEXAS 75265

Copyright © 1982, Texas Instruments Incorporated

SN54ALS242B, SN54ALS243A
SN74ALS242B, SN74ALS243A
QUADRUPLE BUS TRANSCEIVERS WITH 3-STATE OUTPUTS

recommended operating conditions

		SN54ALS242B SN54ALS243A			SN74ALS242B SN74ALS243A			UNIT
		MIN	NOM	MAX	MIN	NOM	MAX	
V _{CC}	Supply voltage	4.5	5	5.5	4.5	5	5.5	V
V _{IH}	High-level input voltage	2			2			V
V _{IL}	Low-level input voltage	0.7			0.8			V
I _{OH}	High-level output current	-12			-15			mA
I _{OL}	Low-level output current	12			24			mA
					48 [†]			
T _A	Operating free-air temperature	-55			125			°C

[†] The 48-mA limit applies only to the -1 versions, and only if V_{CC} is maintained between 4.75 V and 5.25 V.

electrical characteristics over recommended operating free-air temperature range (unless otherwise noted)

PARAMETER	TEST CONDITIONS	SN54ALS242B SN54ALS243A		SN74ALS242B SN74ALS243A		UNIT		
		MIN	TYP [†]	MAX	MIN		TYP [†]	MAX
V _{IK}	V _{CC} = 4.5 V, I _I = -18 mA	-1.2		-1.2		V		
V _{OH}	V _{CC} = 4.5 V to 5.5 V, I _{OH} = -0.4 mA	V _{CC} - 2		V _{CC} - 2		V		
	V _{CC} = 4.5 V, I _{OH} = -3 mA	2.4	3.2	2.4	3.2			
	V _{CC} = 4.5 V, I _{OH} = -12 mA	2						
	V _{CC} = 4.5 V, I _{OH} = -15 mA			2				
V _{OL}	V _{CC} = 4.5 V, I _{OL} = 12 mA	0.25	0.4	0.25	0.4	V		
	V _{CC} = 4.5 V, I _{OL} = 24 mA			0.35	0.5			
	V _{CC} = 4.75 V, I _{OL} = 48 mA (-1 versions)			0.35	0.5			
I _I	Control inputs	V _{CC} = 5.5 V, V _I = 7 V		0.1		mA		
	A or B ports	V _{CC} = 5.5 V, V _I = 5.5 V		0.1				
I _{IH}	Control inputs	V _{CC} = 5.5 V, V _I = 2.7 V		20		μA		
	A or B ports [‡]			20				
I _{IL}	Control inputs	V _{CC} = 5.5 V, V _I = 0.4 V		-0.1		mA		
	A or B ports [‡]			-0.1				
I _O [§]	V _{CC} = 5.5 V, V _O = 2.25 V	-30	-112	-30	-112	mA		
I _{CC}	'ALS242B	V _{CC} = 5.5 V	Outputs high	10	20	10	16	mA
			Outputs low	14	26	14	21	
			Outputs disabled	12	24	12	19	
	'ALS243A		Outputs high	15	30	15	25	
			Outputs low	20	35	20	30	
			Outputs disabled	21	37	21	32	

[†] All typical values are at V_{CC} = 5 V, T_A = 25°C.

[‡] For I/O ports, the parameters I_{IH} and I_{IL} include the off-state output current.

[§] The output conditions have been chosen to produce a current that closely approximates one half of the true short-circuit output current, I_{OS}.

SN54ALS242B, SN54ALS243A
SN54ALS242B, SN54ALS243A
QUADRUPLE BUS TRANSCEIVERS WITH 3-STATE OUTPUTS

'ALS242B switching characteristics (see Note 1)

PARAMETER	FROM (INPUT)	TO (OUTPUT)	V _{CC} = 5 V, C _L = 50 pF, R1 = 500 Ω, R2 = 500 Ω, T _A = 25°C		V _{CC} = 4.5 V to 5.5 V, C _L = 50 pF, R1 = 500 Ω, R2 = 500 Ω, T _A = MIN to MAX		UNIT	
			'ALS242B		SN54ALS242B			
			TYP	MIN	MAX	MIN		MAX
t _{PLH}	A or B	B or A	5	2	15	2	11	ns
t _{PHL}			5	2	14	2	10	
t _{PZH}	GAB	B	10	4	22	4	18	ns
t _{PZL}			11	7	25	7	21	
t _{PHZ}	GAB	B	6	2	16	2	14	ns
t _{PLZ}			5	2	18	2	12	
t _{PZH}	GBA	A	10	4	22	4	18	ns
t _{PZL}			11	7	25	7	21	
t _{PHZ}	GBA	A	6	2	16	2	14	ns
t _{PLZ}			5	2	18	2	12	

'ALS243A switching characteristics (see Note 1)

PARAMETER	FROM (INPUT)	TO (OUTPUT)	V _{CC} = 4.5 V to 5.5 V, C _L = 50 pF, R1 = 500 Ω, R2 = 500 Ω, T _A = MIN to MAX				UNIT
			SN54ALS243A		SN74ALS243A		
			MIN	MAX	MIN	MAX	
t _{PLH}	A or B	B or A	4	15	4	11	ns
t _{PHL}			4	15	4	11	
t _{PZH}	$\bar{G}AB$	B	7	25	7	20	ns
t _{PZL}			7	25	7	20	
t _{PHZ}	$\bar{G}AB$	B	2	16	2	14	ns
t _{PLZ}			3	27	3	22	
t _{PZH}	GBA	A	7	25	7	20	ns
t _{PZL}			7	25	7	20	
t _{PHZ}	GBA	A	2	16	2	14	ns
t _{PLZ}			3	27	3	22	

NOTE 1: Load circuit and voltage waveforms are shown in Section 1.

2

ALS and AS Circuits

**SN54AS242, SN54AS243
SN74AS242, SN74AS243
QUADRUPLE BUS TRANSCEIVERS WITH 3-STATE OUTPUTS**

'AS242 switching characteristics (see Note 1)

PARAMETER	FROM (INPUT)	TO (OUTPUT)	$V_{CC} = 4.5 \text{ V to } 5.5 \text{ V,}$ $C_L = 50 \text{ pF,}$ $R_1 = 500 \Omega,$ $R_2 = 500 \Omega,$ $T_A = \text{MIN to MAX}$				UNIT
			SN54AS242		SN74AS242		
			MIN	MAX	MIN	MAX	
t_{PLH}	A or B	B or A	2	7	2	6.5	ns
t_{PHL}			2	6	2	5.7	
t_{PZH}	$\bar{G}AB$	B	2	9	2	5.5	ns
t_{PZL}			2	8.5	2	7.5	
t_{PHZ}	$\bar{G}AB$	B	2	7	2	6.5	ns
t_{PLZ}			2	12.5	2	9.5	
t_{PZH}	GBA	A	3	7	3	6	ns
t_{PZL}			3	9	3	8	
t_{PHZ}	GBA	A	3	8.5	3	6	ns
t_{PLZ}			3	13.5	3	10.5	

'AS243 switching characteristics (see Note 1)

PARAMETER	FROM (INPUT)	TO (OUTPUT)	$V_{CC} = 4.5 \text{ V to } 5.5 \text{ V,}$ $C_L = 50 \text{ pF,}$ $R_1 = 500 \Omega,$ $R_2 = 500 \Omega,$ $T_A = \text{MIN to MAX}$				UNIT
			SN54AS243		SN74AS243		
			MIN	MAX	MIN	MAX	
t_{PLH}	A or B	B or A	3	9	3	7.5	ns
t_{PHL}			3	8	3	6.5	
t_{PZH}	$\bar{G}AB$	B	2	10	2	9	ns
t_{PZL}			2	9	2	7.5	
t_{PHZ}	$\bar{G}AB$	B	2	7	2	6.5	ns
t_{PLZ}			2	11	2	9	
t_{PZH}	GBA	A	3	11	3	10.5	ns
t_{PZL}			3	9.5	3	8.5	
t_{PHZ}	GBA	A	3	7.5	3	7	ns
t_{PLZ}			3	14	3	11	

NOTE 1: Load circuit and voltage waveforms are shown in Section 1.