

## AM26LS32, AM26LS33

### Quad Differential Line Receivers

The AM26LS32 is a quad line receiver designed to meet the requirements of RS-422 and RS-423, and Federal Standards 1020 and 1030 for balanced and unbalanced digital data transmission.

The AM26LS32 features an input sensitivity of 200 mV over the input voltage range of  $\pm 7V$ . The AM26LS33 features an input sensitivity of 500 mV over the input voltage range of  $\pm 15 V$ .

#### Rochester Electronics Manufactured Components

Rochester branded components are manufactured using either die/wafers purchased from the original suppliers or Rochester wafers recreated from the original IP. All recreations are done with the approval of the OCM.

Parts are tested using original factory test programs or Rochester developed test solutions to guarantee product meets or exceeds the OCM data sheet.

#### Quality Overview

- ISO-9001
- AS9120 certification
- Qualified Manufacturers List (QML) MIL-PRF-38535
  - Class Q Military
  - Class V Space Level
- Qualified Suppliers List of Distributors (QSLD)
  - Rochester is a critical supplier to DLA and meets all industry and DLA standards.

Rochester Electronics, LLC is committed to supplying products that satisfy customer expectations for quality and are equal to those originally supplied by industry manufacturers.

*The original manufacturer's datasheet accompanying this document reflects the performance and specifications of the Rochester manufactured version of this device. Rochester Electronics guarantees the performance of its semiconductor products to the original OEM specifications. 'Typical' values are for reference purposes only. Certain minimum or maximum ratings may be based on product characterization, design, simulation, or sample testing.*



# Am26LS32/Am26LS33

## Quad Differential Line Receivers

### DISTINCTIVE CHARACTERISTICS

- Input voltage range of 15 V (differential or common mode) on Am26LS33; 7 V (differential or common mode) on Am26LS32
  - 200 mV sensitivity over the input voltage range on Am26LS32;
  - 500 mV sensitivity on Am26LS33
- 6k minimum input impedance with 30 mV input hysteresis
- The Am26LS32 meets all the requirements of RS-422 and RS-423
- Operation from single +5 V supply
- Fail safe input-output relationship. Output always high when inputs are open
- Three-state drive, with choice of complementary output enables, for receiving directly onto a data bus

### GENERAL DESCRIPTION

The Am26LS32 is a quad line receiver designed to meet the requirements of RS-422 and RS-423, and Federal Standards 1020 and 1030 for balanced and unbalanced digital data transmission.

The Am26LS32 features an input sensitivity of 200 mV over the input voltage range of  $\pm 7$  V.

The Am26LS33 features an input sensitivity of 500 mV over the input voltage range of  $\pm 15$  V.

The Am26LS32 and Am26LS33 provide an enable and disable function common to all four receivers. Both parts feature 3-state outputs with 8 mA sink capability and incorporate a fail safe input-output relationship which keeps the outputs high when the inputs are open.

The Am26LS32 and Am26LS33 are constructed using Advanced Low-Power Schottky processing.

### BLOCK DIAGRAM

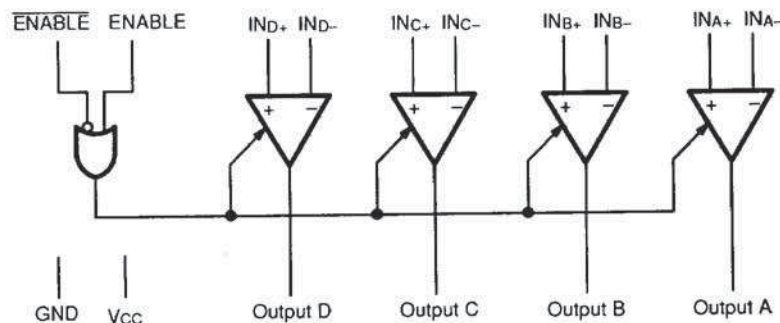

05393-001B

### RELATED AMD PRODUCTS

Part No.	Description
26LS29	Quad Three-State Single Ended RS-423 Line Driver
26LS30	Dual Differential RS-422 Party Line/Quad Single Ended RS-423 Line Driver
26LS31	Quad High Speed Differential Line Driver

**CONNECTION DIAGRAMS**  
Top View

**DIP**

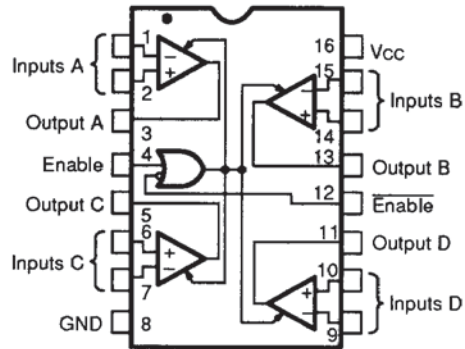

05393-002B

**LCC**

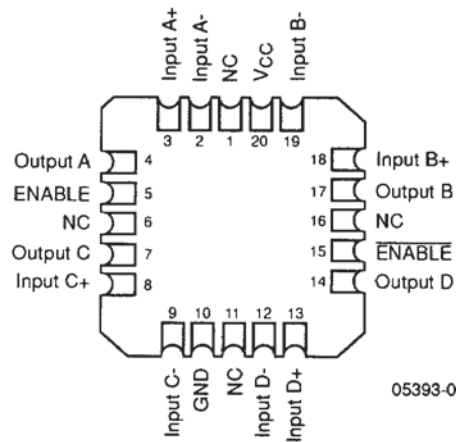

05393-003B

**Note:**  
Pin 1 is marked for orientation.

**ORDERING INFORMATION**  
**Standard Products**

AMD standard products are available in several packages and operating ranges. The order number (Valid Combination) is formed by a combination of:

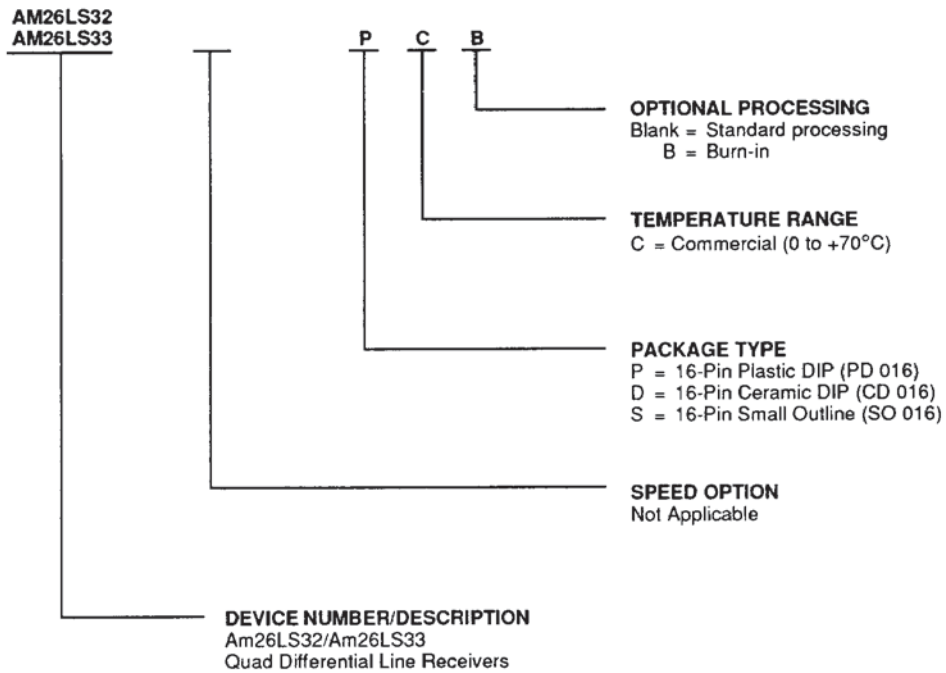

Valid Combinations	
AM26LS32	PC, PCB, DC,
AM26LS33	DCB, SC

**Valid Combinations**

Valid Combinations list configurations planned to be supported in volume for this device. Consult the local AMD sales office to confirm availability of specific valid combinations or to check on newly released combinations, and to obtain additional data on AMD's standard military grade products.

**MILITARY ORDERING INFORMATION**  
**Standard Military Drawing (SMD)/DESC Products**

AMD products for Aerospace and Defense applications are available in several packages and operating ranges. Standard Military Drawing (SMD)/DESC products are fully compliant with MIL-STD-883C requirements. The order number (Valid Combination) for SMD/DESC products is formed by a combination of:

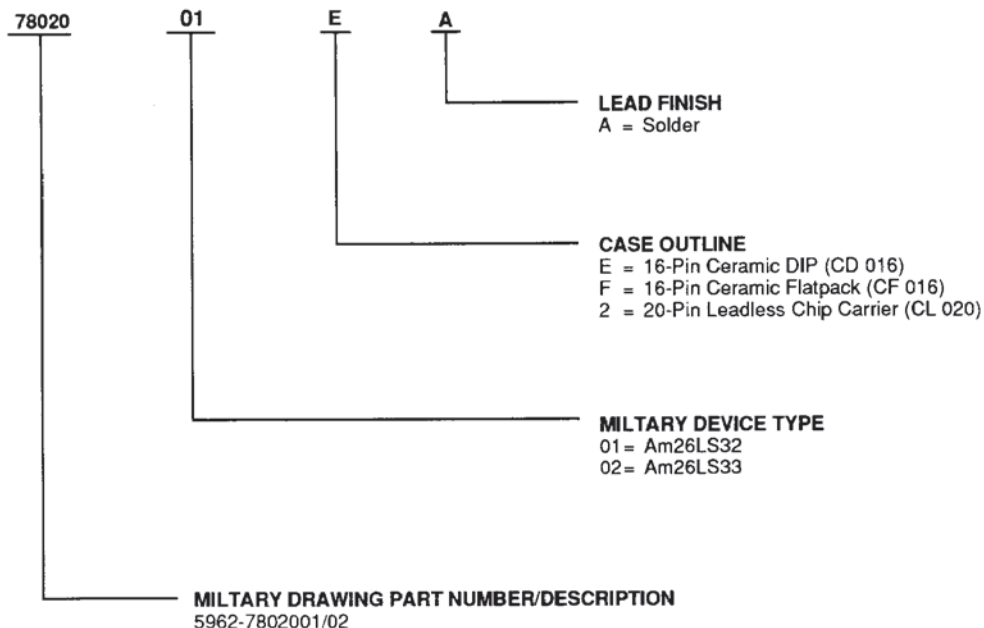

Valid Combinations	
5962-7802001	MEA, MFA, M2A
5962-7802002	

**Valid Combinations**

Valid Combinations list configurations planned to be supported in volume for this device. Consult the local AMD sales office to confirm availability of specific valid combinations, or to check on newly released combinations.

**Group A Tests**

Group A tests consist of Subgroups 1, 2, 3, 7, 8, 9, 10, 11.





### ABSOLUTE MAXIMUM RATINGS

Supply Voltage	7.0 V
Common Mode Range	±25 V
Differential Input Voltage	±25 V
Enable Voltage	7.0 V
Output Sink Current	50 mA
Storage Temperature Range	-65 to +165°C

### OPERATING RANGES

<b>Commercial (C) Devices</b>	
Temperature	0 to +70°C
Supply Voltage	+4.75 V to +5.25 V
<b>Military (M) Devices</b>	
Temperature	-55 to +125°C
Supply Voltage	+4.5 V to +5.5 V

Stresses above those listed under Absolute Maximum Ratings may cause permanent device failure. Functionality at or above these limits is not implied. Exposure to absolute maximum ratings for extended periods may affect device reliability.

Operating ranges define those limits between which the functionality of the device is guaranteed.

### DC CHARACTERISTICS over operating ranges unless otherwise specified

Parameter Symbol	Parameter Description	Test Conditions	Min.	Typ. (Note 1)	Max.	Unit
V <sub>TH</sub>	Differential Input Voltage	V <sub>OUT</sub> = V <sub>OL</sub> or V <sub>OH</sub> (Note 5) Am26LS32, -7 V ≤ V <sub>CM</sub> ≤ +7 V	-0.2	±0.06	+0.2	V
		Am26LS33, -15 V ≤ V <sub>CM</sub> ≤ +15 V	-0.5	±0.12	+0.5	
R <sub>IN</sub>	Input Resistance	-15 V ≤ V <sub>CM</sub> ≤ +15 V (One input AC ground) (Note 4)	6.0	9.8		kΩ
I <sub>IN</sub>	Input Current (Under Test)	V <sub>IN</sub> = +15 V, Other Input -15 V ≤ V <sub>IN</sub> ≤ +15 V			2.3	mA
I <sub>IN</sub>	Input Current (Under Test)	V <sub>IN</sub> = -15 V, Other Input -15 V ≤ V <sub>IN</sub> ≤ +15 V			-2.8	mA
V <sub>OH</sub>	Output HIGH Voltage	V <sub>CC</sub> = Min., ΔV <sub>IN</sub> = +1.0 V V <sub>ENABLE</sub> = 0.8 V, I <sub>OH</sub> = -440 μA	COM'L	2.7	3.4	V
		MIL	2.5	3.4		
V <sub>OL</sub>	Output LOW Voltage	V <sub>CC</sub> = Min., ΔV <sub>IN</sub> = -1.0 V V <sub>ENABLE</sub> = 0.8 V	I <sub>OL</sub> = 4.0 mA		0.4	V
		I <sub>OL</sub> = 8.0 mA		0.45		
V <sub>IL</sub>	Enable LOW Voltage	(Note 2)			0.8	V
V <sub>IH</sub>	Enable HIGH Voltage	(Note 2)	2.0			V
V <sub>IC</sub>	Enable Clamp Voltage	V <sub>CC</sub> = Min., I <sub>IN</sub> = -18 mA			-1.5	V
I <sub>O</sub>	Off-state (High Impedance) Output Current	V <sub>CC</sub> = Max.	V <sub>O</sub> = 2.4 V		20	μA
			V <sub>O</sub> = 0.4 V		-20	
I <sub>IL</sub>	Enable LOW Current	V <sub>IN</sub> = 0.4 V, V <sub>CC</sub> = Max.		-0.2	-0.36	mA
I <sub>IH</sub>	Enable HIGH Current	V <sub>IN</sub> = 2.7 V, V <sub>CC</sub> = Max.			20	μA
I <sub>I</sub>	Enable Input High Current	V <sub>IN</sub> = 5.5 V, V <sub>CC</sub> = Max.			100	μA
I <sub>SC</sub>	Output Short Circuit Current	V <sub>O</sub> = 0 V, V <sub>CC</sub> = Max., ΔV <sub>IN</sub> = +1.0 V (Note 3)	-15	-50	-85	mA
I <sub>CC</sub>	Power Supply Current	V <sub>CC</sub> = Max., All V <sub>IN</sub> = GND, Outputs Disabled		52	70	mA
V <sub>HYST</sub>	Input Hysteresis	T <sub>A</sub> = 25°C, V <sub>CC</sub> = 5.0 V, V <sub>CM</sub> = 0 V		30		mV

#### Notes:

- All typical values are V<sub>CC</sub> = 5.0 V, T<sub>A</sub> = 25°C.
- Input thresholds are tested during DC tests and may be done in combination with testing of other DC parameters.
- Not more than one output should be shorted at a time. Duration of short circuit test should not exceed one second.
- R<sub>IN</sub> is not directly tested but is correlated. (See Attachment I)
- Input voltage is not tested directly due to tester accuracy limitation but is threshold correlated. (See Attachment II)

**SWITCHING CHARACTERISTICS**





Parameter Symbol	Parameter Description	Test Conditions	Min.	Typ. (Note 1)	Max.	Unit
<b>AC Parameters (T<sub>A</sub> = +25°C)</b>						
t <sub>PLH</sub>	Propagation Delay From Input to Output	C <sub>L</sub> 15 pF, R <sub>L1</sub> = 5 kΩ, R <sub>L2</sub> = 2 kΩ, V <sub>CC</sub> = 5.0		17	25	ns
t <sub>PHL</sub>	Propagation Delay From Input to Output	C <sub>L</sub> 15 pF, R <sub>L1</sub> = 5 kΩ, R <sub>L2</sub> = 2 kΩ, V <sub>CC</sub> = 5.0		17	25	ns
t <sub>LZ</sub>	Enable to Output	V <sub>CC</sub> = 5.0, C <sub>L</sub> 5 pF, R <sub>L1</sub> = 5 kΩ, R <sub>L2</sub> = 2 kΩ		20	30	ns
t <sub>HZ</sub>	Enable to Output	V <sub>CC</sub> = 5.0, C <sub>L</sub> 5 pF, R <sub>L1</sub> = 5 kΩ, R <sub>L2</sub> = 2 kΩ		15	22	ns
t <sub>ZL</sub>	Enable to Output	V <sub>CC</sub> = 5.0, C <sub>L</sub> 15 pF, R <sub>L1</sub> = 5 kΩ, R <sub>L2</sub> = 2 kΩ		15	22	ns
t <sub>ZH</sub>	Enable to Output	V <sub>CC</sub> = 5.0, C <sub>L</sub> 15 pF, R <sub>L1</sub> = 5 kΩ, R <sub>L2</sub> = 2 kΩ		15	22	ns
<b>AC Parameters (-55°C to +125°C)</b>						
t <sub>PLH</sub>	Propagation Delay From Input to Output	C <sub>L</sub> 15 pF, R <sub>L1</sub> = 5 kΩ, R <sub>L2</sub> = 2 kΩ,		23	38	ns
t <sub>PHL</sub>	Propagation Delay From Input to Output	C <sub>L</sub> 15 pF, R <sub>L1</sub> = 5 kΩ, R <sub>L2</sub> = 2 kΩ		22	38	ns
t <sub>PZH</sub>	Propagation Delay From Enable to Output	C <sub>L</sub> 15 pF, R <sub>L1</sub> = 5 kΩ, R <sub>L2</sub> = 2 kΩ		17	33	ns
t <sub>PZL</sub>	Propagation Delay From Enable to Output	C <sub>L</sub> 15 pF, R <sub>L1</sub> = 5 kΩ, R <sub>L2</sub> = 2 kΩ		25	33	ns
t <sub>PHZ</sub>	Propagation Delay From Enable to Output	C <sub>L</sub> 5 pF, R <sub>L1</sub> = 5 kΩ, R <sub>L2</sub> = 2 kΩ		18	33	ns
t <sub>PLZ</sub>	Propagation Delay From Enable to Output	C <sub>L</sub> 5 pF, R <sub>L1</sub> = 5 kΩ, R <sub>L2</sub> = 2 kΩ		24	45	ns
<b>Tristate Delays for Enable (T<sub>A</sub> = +25°C)</b>						
t <sub>PZH</sub>	Propagation Delay From Enable to Output	C <sub>L</sub> 15 pF, R <sub>L1</sub> = 5 kΩ, R <sub>L2</sub> = 2 kΩ		16	32	ns
t <sub>PZL</sub>	Propagation Delay From Enable to Output	C <sub>L</sub> 15 pF, R <sub>L1</sub> = 5 kΩ, R <sub>L2</sub> = 2 kΩ		23	33	ns
t <sub>PHZ</sub>	Propagation Delay From Enable to Output	C <sub>L</sub> 5 pF, R <sub>L1</sub> = 5 kΩ, R <sub>L2</sub> = 2 kΩ		14	24	ns
t <sub>PLZ</sub>	Propagation Delay From Enable to Output	C <sub>L</sub> 5 pF, R <sub>L1</sub> = 5 kΩ, R <sub>L2</sub> = 2 kΩ		14	32	ns
<b>Tristate Delays for Enable (-55°C to +125°C)</b>						
t <sub>PZH</sub>	Propagation Delay From Enable to Output	C <sub>L</sub> 15 pF, R <sub>L1</sub> = 5 kΩ, R <sub>L2</sub> = 2 kΩ		23	48	ns
t <sub>PZL</sub>	Propagation Delay From Enable to Output	C <sub>L</sub> 15 pF, R <sub>L1</sub> = 5 kΩ, R <sub>L2</sub> = 2 kΩ		35	50	ns
t <sub>PHZ</sub>	Propagation Delay From Enable to Output	C <sub>L</sub> 5 pF, R <sub>L1</sub> = 5 kΩ, R <sub>L2</sub> = 2 kΩ		20	36	ns
t <sub>PLZ</sub>	Propagation Delay From Enable to Output	C <sub>L</sub> 5 pF, R <sub>L1</sub> = 5 kΩ, R <sub>L2</sub> = 2 kΩ		22	48	ns

**Note:**

1. All typical values are V<sub>CC</sub> = 5.0 V, T<sub>A</sub> = 25°C.



**KEY TO SWITCHING WAVEFORMS**

WAVEFORM	INPUTS	OUTPUTS
	Must Be Steady	Will Be Steady
	May Change from H to L	Will Be Changing from H to L
	May Change from L to H	Will Be Changing from L to H
	Don't Care, Any Change Permitted	Changing, State Unknown
	Does Not Apply	Center Line is High Impedance "Off" State

KS000010

**SWITCHING WAVEFORMS**

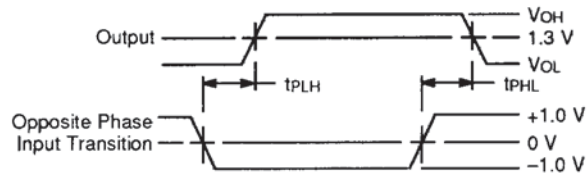

**Propagation Delay (Notes 1 and 3)**

05393-004B

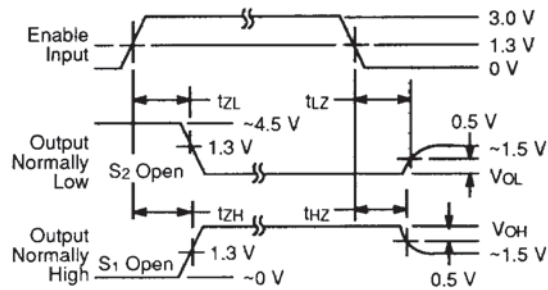

**Enable and Disable Times (Notes 2 and 3)**

05393-005B

**Notes:**

1. Diagram shown for  $\overline{\text{ENABLE}}$  LOW.
2. S<sub>1</sub> and S<sub>2</sub> of Load Circuit are closed except where shown.
3. Pulse Generator for All Pulses: Rate ≤ 1.0 MHz; Z<sub>0</sub> = 50 Ω; t<sub>r</sub> ≤ 15 ns; t<sub>f</sub> ≤ 6.0 ns.

**SWITCHING TEST CIRCUIT FOR THREE-STATE OUTPUTS**

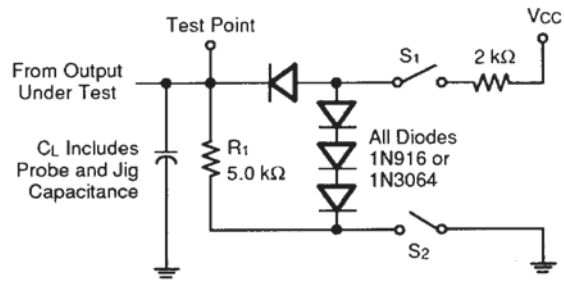

05393-006B

## Am26LS32/32B/33/34 Input Resistance and Input Current (Attachment I)

Input resistance measurement for differential inputs on line receivers are generally not measured directly. Instead they are correlated to an input current measurement and to the process resistor temperature coefficient. The assumptions made include 1) Process resistor temperature coefficient is known and 2) The open input bias voltage for the input is known or measured within the same test sequence.

Under the above assumptions  $R_{IN}$  can be correlated to the input current measured. The expression

$$R_{IN} = \frac{(V_{ICM} - V_{IN}) (R_T)}{(I_{IN}) (R_{25})}$$

where  $V_{ICM}$  is the open input bias voltage of the Line Receiver. When applying this correlation to the 26LS32 die, the following criteria have been set.

- 1)  $V_{ICM}$  and  $I_{IN}$  are the values screened at wafer sort.
- 2) Temperature coefficients are for 800 ohm/square which gives 0.96 at 0°C and 0.93 at -55°C.

When setting limits, characterized values for  $V_{ICM}$  have been used instead of the test programmed limit value.  $R_{IN} (dif)$  is  $R_{IN} (dif) = 2 R_{IN}$ .

For the Am26LS32/32B/33/34

$$R_{IN} \text{ Min.} = \frac{(2.56 - -15) 0.96}{I_{IN} (\text{Max.})} = 16.8/I_{IN} (\text{Max.}) \text{ Comm.},$$

and

$$R_{IN} \text{ Min.} = 16.3/I_{IN} (\text{Max.}) \text{ Mil.}$$

### Worst Case Measurement for Input Current

Two considerations have been used to determine the test condition for input current of the data path for the Am26LS32 Line Receiver.

- 1) Input current is tested on the 26LS32 with the pin under test at one end of the range (+15 V for example) and the untested pin at the opposite extreme of the input range under test. If both pins were at the same test voltage the internal bias generator would have a lower output voltage for tests at -15 V  $V_{IN}$  and a higher output voltage at +15 V  $V_{IN}$ . This would produce test currents less than maximum.
- 2) For the 26LS32, breakdown of the differential inputs is the primary failure to the data sheet specification. Hence, both breakdown voltage and input current are tested during the input current tests.

## Test Documentation For Am26LS32/32B/34 $V_{TH}$ (Attachment II)

Input threshold ( $V_{TH}$ ) for the Am26LS32/32B/34 is described by the equation,

$$V_{TH} = (N+1) (1+R1/R) K^*T/Q ((1+Rh/(m (Rc+Rh))) / (1-Rh/ (M(Rc+Rh))))$$

Where  $N+1$  is the attenuator ratio,  $R1/R$  is the attenuator ratio mismatch,  $M$  is the ratio of the input stage current to hysteresis stage current, and  $Rh$  and  $Rc$  are input stage loads. For Am26LS32 – 34 devices which pass function tests,  $V_{OH}$  and  $V_{OL}$  tests, thresholds for all inputs within the operating range of the circuit.

The Test system is unable to force input thresholds within the accuracy required for the Am26LS32 – 34 specifications. Figure 1 plots the expected values for  $V_{TH}$ , the worst case values at 25°C and 155°C. Also shown are the test values for  $V_{TH}$  at the –1.5 V input ( $V_{IN}$ ). In addition, the test voltage at –7 V  $V_{IN}$  is shown. For the figure it is seen that the worst case value for the test limit shown would be +/-165 mV, where +/- 102 mV

is expected for process parameters and the equation for  $V_{TH}$ . Further the 25 mV negative guardband used for –7 V testing is less than half the machine uncertainty of 60 mV.

When QA testing for Am26LS32/32B/34 is done, thresholds are screened for  $V_{CM}$  other than –1.5 V. These additional tests are considered functional tests only, and the precision threshold tests which insure compliance with data sheet limits are those tests performed where the inputs are tested near –1.5 V.

The actual threshold tests are done as a sequence where a setup is performed which preconditions the DUT to a logic one state, then the threshold correlation for a logic zero is tested followed by a threshold correlation for logic one to complete the sequence. The limit values for the setup ( $V_t$  SET), logic zero test ( $V_t$  “–”), and logic one test ( $V_t$  “+”) are listed under  $V_{TH}$  for supply value of 5.0 V.

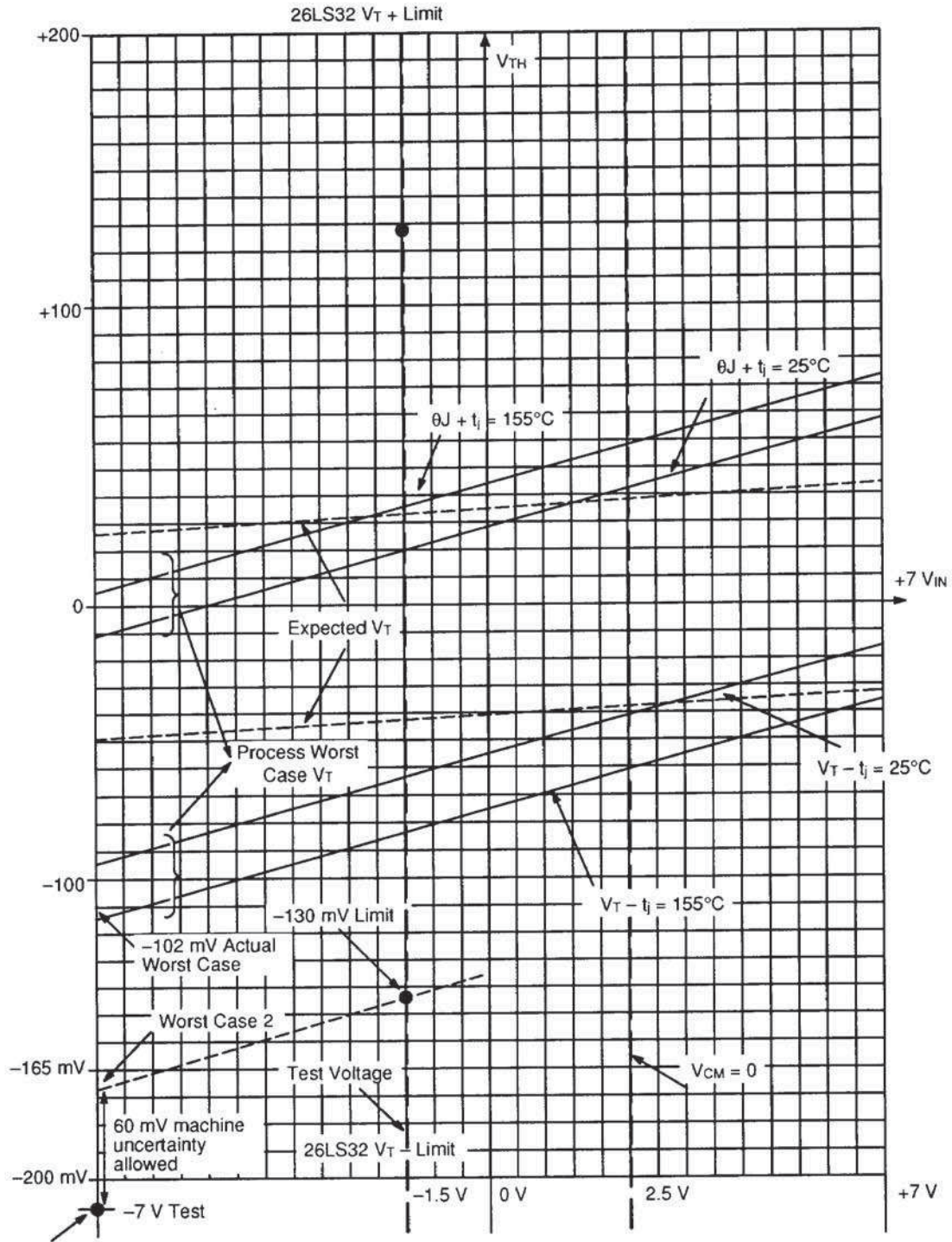

Figure 1. 26LS32 Input Threshold  $V_T$  vs. Input Voltage  $V_{IN}$