

MOX-VTIL-3838 SERIES

VERTICAL MOUNT TOROID INDUCTORS

MoxiE
INDUCTOR CORPORATION



Features:

- Low cost.
- Vertical mounting.
- Reinforced L-pin base to prevent lead shearing.
- Low core loss.
- Horizontal mounting available.
- Encapsulation available.
- MoxiE custom designs available.



DIMENSIONS (mm)

A	B	D	H	W
15.24 ±0.5	22.86 ±0.5	40.65 MAX.	38.10 MAX.	22.86 ±0.5



MECHANICAL

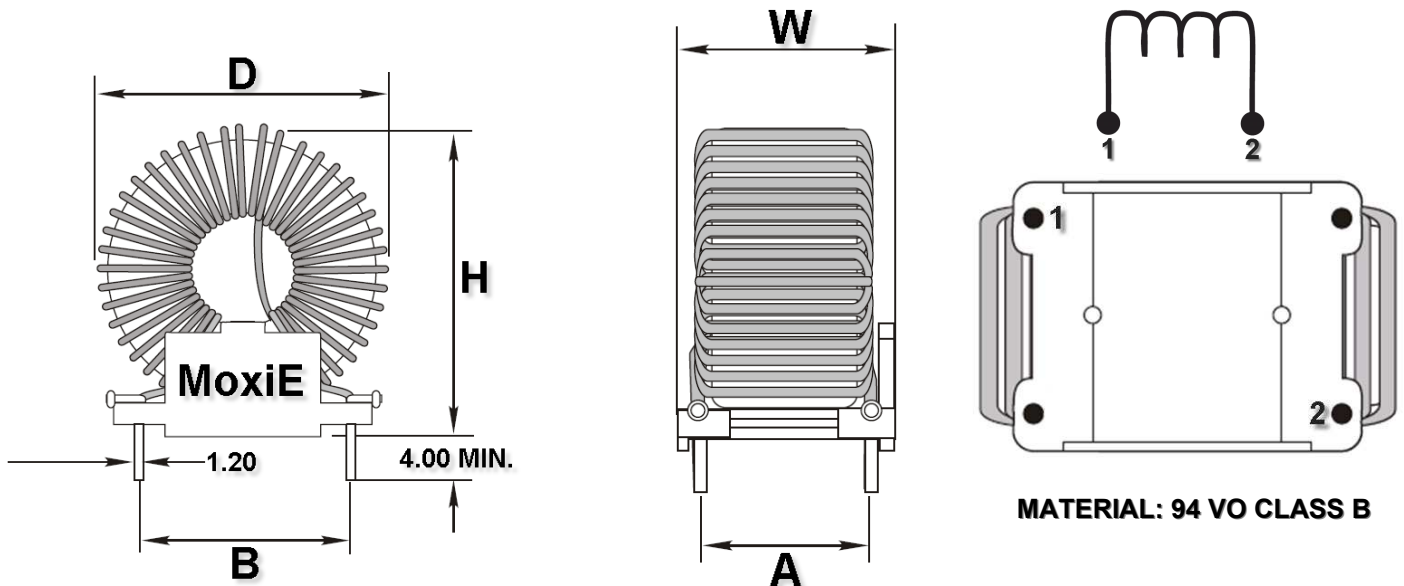

MOX-VTIL-3838 SERIES

VERTICAL MOUNT TOROID INDUCTORS



ELECTRICAL SPECIFICATIONS

MoxiE Part Number	L @ 0 Amps D.C. (μH) ±20%	Max RDC. (Ω)	Suggested Rated Current (Amps)	0% L Drop (DC Amps)	10% L Drop (DC Amps)	20% L Drop (DC Amps)	30% L Drop (DC Amps)	40% L Drop (DC Amps)	50% L Drop (DC Amps)
MOX-VTIL-3838-1R2M	1.2	.004	6.0	7.8	21.7	32.7	45.0	59.1	77.7
MOX-VTIL-3838-2R0M	2.0	.005	5.5	8.8	15.4	24.5	33.8	44.3	58.2
MOX-VTIL-3838-3R3M	3.3	.006	5.5	4.7	13.1	19.8	27.0	35.5	46.6
MOX-VTIL-3838-47RM	4.7	.007	5.5	3.9	10.9	16.4	22.5	29.5	38.8
MOX-VTIL-3838-6R8M	6.8	.008	5.5	3.5	9.3	14.0	19.3	25.3	33.3
MOX-VTIL-3838-8R2M	8.2	.010	5.5	2.9	8.1	12.3	16.9	22.1	29.1
MOX-VTIL-3838-100M	10	.012	5.5	2.6	7.3	10.9	15.0	20.0	25.8
MOX-VTIL-3838-120M	12	.013	5	2.4	6.8	9.8	13.5	17.7	23.3
MOX-VTIL-3838-150M	15	.014	5	2.1	5.9	8.9	12.3	16.1	21.2
MOX-VTIL-3838-180M	18	.016	5	1.9	5.5	8.2	11.3	14.8	18.9
MOX-VTIL-3838-220M	22	.016	5	1.8	5.0	7.5	10.4	13.6	17.4
MOX-VTIL-3838-270M	27	.018	5	1.6	4.4	6.5	9.0	11.8	15.5
MOX-VTIL-3838-330M	33	.020	5	1.4	3.8	5.8	7.9	10.4	13.7
MOX-VTIL-3838-390M	39	.021	5	1.2	3.4	5.2	7.1	9.3	12.2
MOX-VTIL-3838-470M	47	.023	5	1.2	3.3	4.9	6.8	8.8	11.6
MOX-VTIL-3838-560M	56	.025	5	1.0	2.8	4.7	5.9	7.7	10.1
MOX-VTIL-3838-680M	68	.030	5	.93	2.6	3.9	5.1	7.0	9.3
MOX-VTIL-3838-820M	82	.032	5	.83	2.3	3.5	4.8	6.3	8.3
MOX-VTIL-3838-101M	100	.034	5	.75	2.1	3.2	4.4	5.7	7.5
MOX-VTIL-3838-121M	120	.037	5	.70	1.9	3.0	4.1	5.3	7.0
MOX-VTIL-3838-151M	150	.043	5	.64	1.8	2.7	3.7	4.9	6.4
MOX-VTIL-3838-181M	180	.048	5	.57	1.5	2.4	3.3	4.3	5.7
MOX-VTIL-3838-221M	220	.054	5	.51	1.5	2.2	3.0	3.9	5.1
MOX-VTIL-3838-271M	270	.060	5	.48	1.3	2.0	2.8	3.6	4.8
MOX-VTIL-3838-331M	330	.065	5	.43	1.2	1.8	2.5	3.3	4.3
MOX-VTIL-3838-391M	390	.070	5	.39	1.1	1.7	2.3	3.0	3.9
MOX-VTIL-3838-471M	470	.078	5	.36	1.0	1.5	2.1	2.7	3.6
MOX-VTIL-3838-561M	560	.088	5	.32	.90	1.4	1.9	2.5	3.2
MOX-VTIL-3838-681M	680	.135	4.5	.29	.81	1.2	1.7	2.2	2.9
MOX-VTIL-3838-821M	820	.145	4.5	.26	.74	1.1	1.5	2.0	2.6
MOX-VTIL-3838-102M	1000	.165	4.5	.24	.67	1.0	1.4	1.8	2.4
MOX-VTIL-3838-121M	1200	.190	3.5	.21	.59	.89	1.2	1.6	2.1
MOX-VTIL-3838-151M	1500	.350	2.0	.19	.52	.78	1.1	1.4	1.9
MOX-VTIL-3838-181M	1800	.380	2.0	.17	.48	.72	.99	1.3	1.7
MOX-VTIL-3838-221M	2200	.450	2.0	.15	.43	.65	.90	1.2	1.6
MOX-VTIL-3838-271M	2700	.550	2.0	.12	.38	.58	.78	1.1	1.4

MOXIE ENGINEERING NOTES:

- Leads for PC mounting are tinned to within 16mm (1/16") of body
- RDC is measured at 20°C.
- Saturation currents shown are for maximum drop of L indicated.
- RoHS compliant.
- MoxiE Inductor Corporation specifications are subject to change without notice.
- MoxiE Inductor Corporation custom designed products are subject to United States copyright and or United States patent protection(s).