

# MOX-CMF-5864 SERIES

## SMD EMC COMMON MODE FILTER

### Features:

- Low cost.
- RoHS compliant.
- Dual common mode choke coils.
- Low profile 8-pin half pitch surface mount design.
- Suitable for reflow soldering.
- Preventive measure against USB & IEEE 1394 radiation.
- Suppresses radiated emissions from peripheral devices.
- High performance ferrite material for excellent frequency characteristics.
- MoxiE Inductor Corporation custom designs available.



## NOTES

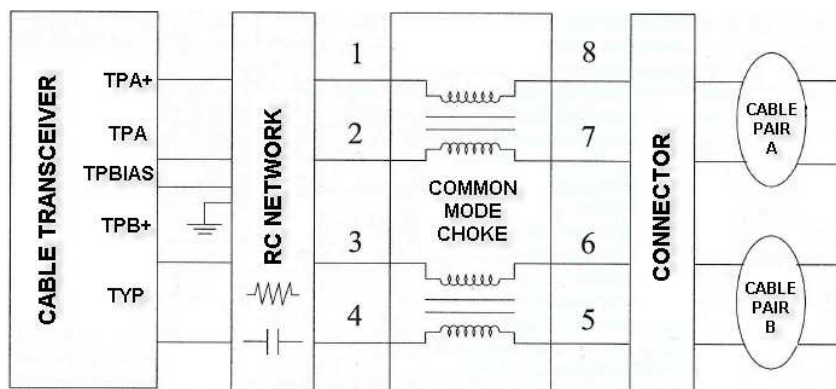

## MECHANICAL DIMENSIONS (mm)

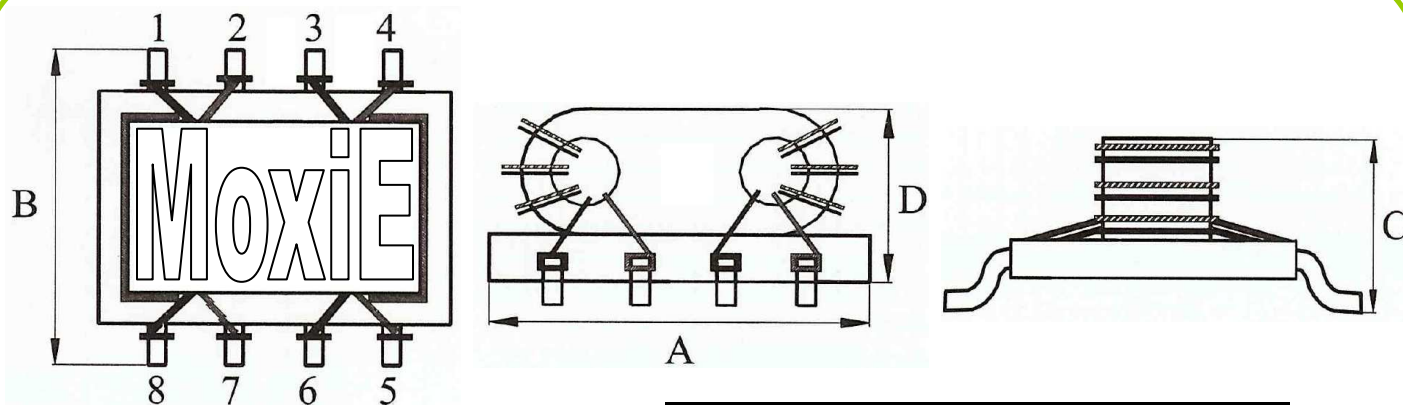

A	B	C	D
5.85±0.5	6.40±0.5	3.10±0.5	3.00±0.5



## SCHEMATICS

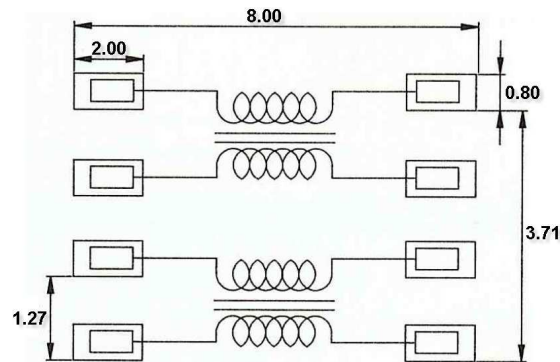

MoxiE note:  
All dimensions in mm



## ELECTRICAL SPECIFICATIONS

MoxiE Part Number	Insertion Loss(dB)				Impedance ( Ω )				RDC (Max.) ( Ω /line)	IDC (Max.) (mA)	Withstand (Voltage) V
	50MHz	100MHz	300MHz	500 MHz	50 MHz	100 MHz	300 MHz	500 MHz			
MOX-CMF-5864-1	2.8 + 2.0	4.3 + 2.5	6.1 + 3.0	6.7 + 3.0	75	75	120	170	0.12	500	80
MOX-CMF-5864-2	6.0 + 2.0	8.2 + 2.5	10.6 + 2.5	11.1 + 3.0	120	120	260	230	0.12	500	80
MOX-CMF-5864-3	9.5 + 2.0	12 + 2.5	14.5 + 2.5	14.8 + 3.0	300	300	460	220	0.12	500	80
MOX-CMF-5864-4	12.5 + 2.0	15.3 + 2.5	17.8 + 2.5	17.1 + 3.0	530	530	680	200	0.12	500	80
MOX-CMF-5864-5	15.3 + 2.0	18.2 + 2.5	20 + 2.5	17.8 + 3.0	800	800	770	200	0.12	500	80
MOX-CMF-5864-6	17.5 + 2.0	20.6 + 2.5	21.2 + 2.5	17.7 + 3.0	1200	1200	760	190	0.12	500	80
MOX-CMF-5864-7	20.0 + 2.0	23.0 + 2.5	22.3 + 2.5	17.8 + 3.0	1600	1600	730	180	0.12	500	80
MOX-CMF-5864-8	22.5 + 2.0	25.6 + 2.5	20.8 + 2.5	15.6 + 3.0	1800	1800	680	170	0.12	500	80



## ENGINEERING NOTES

- Packaging: Tape & reel (1,000 pieces per reel)
- Operating temperature range  $-10^{\circ}$  TO  $+70^{\circ}$ C.
- MoxiE Inductor Corporation specifications are subject to change without notice.
- MoxiE Inductor Corporation custom products are subject to United States Copyright and or Patent protection(s).



## CURVES

MOXIE MOX-CMF-5864-1

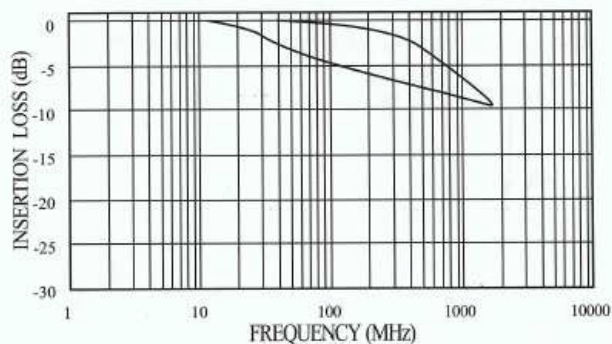
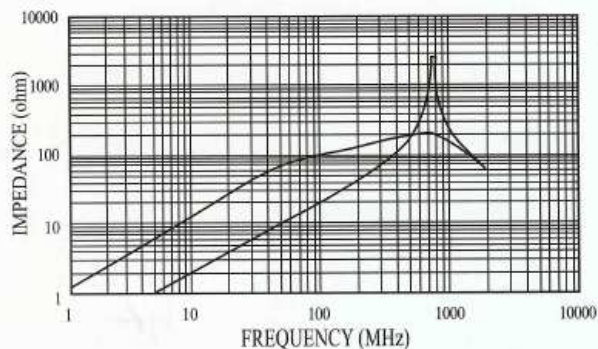

MOXIE MOX-CMF-5864-2

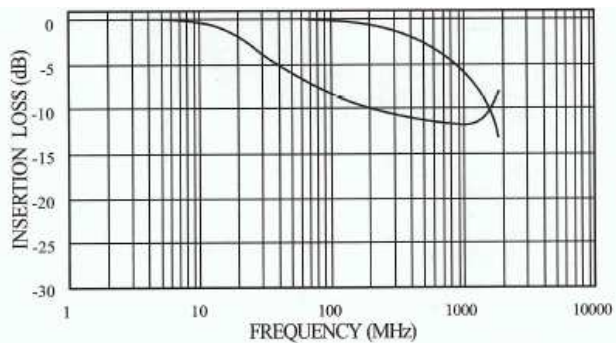
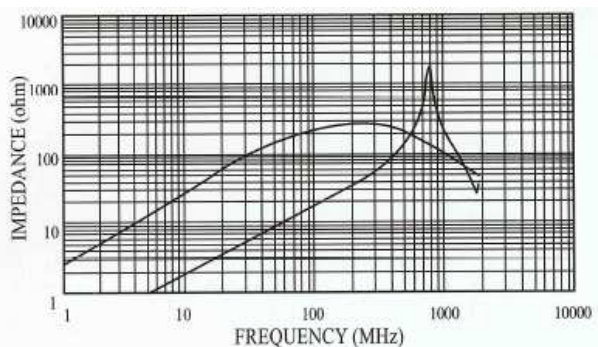

MOXIE MOX-CMF-5864-3

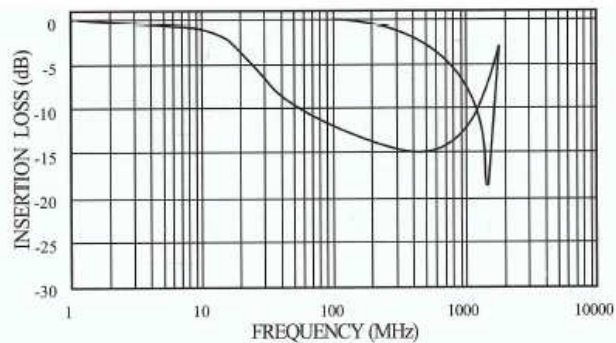
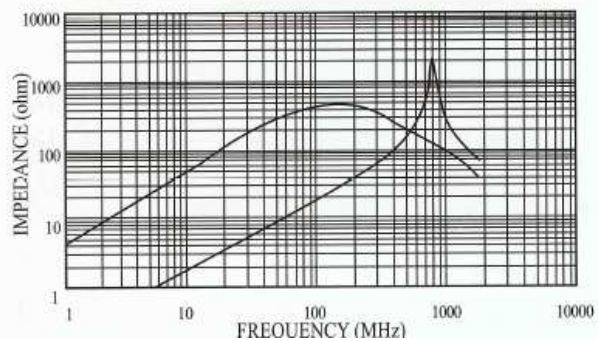

MOXIE MOX-CMF-5864-4

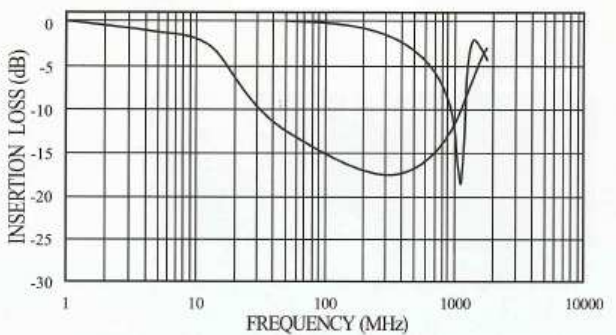
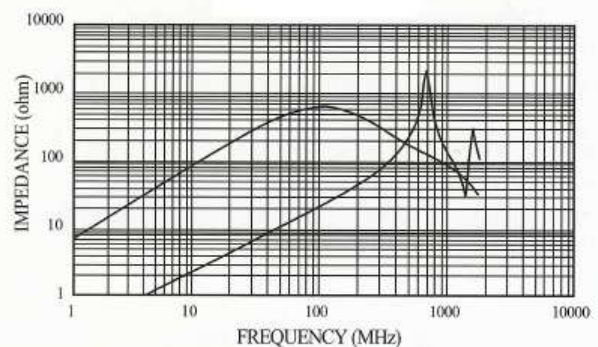



## CURVES

MOXIE MOX-CMF-5864-5

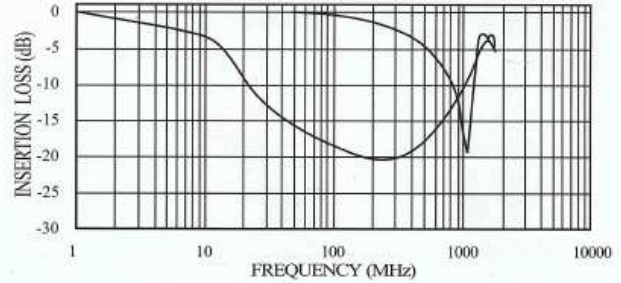
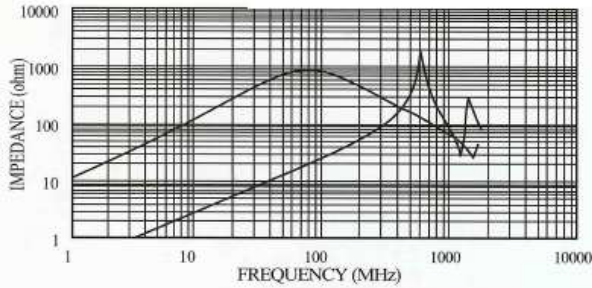

MOXIE MOX-CMF-5864-6

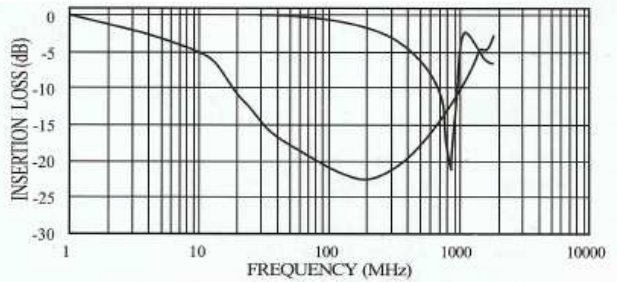
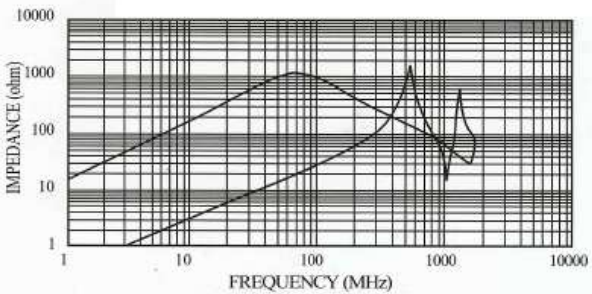

MOXIE MOX-CMF-5864-7

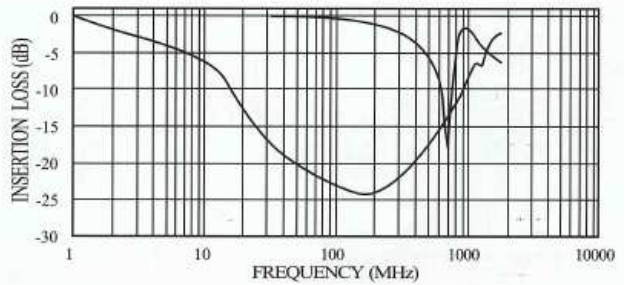
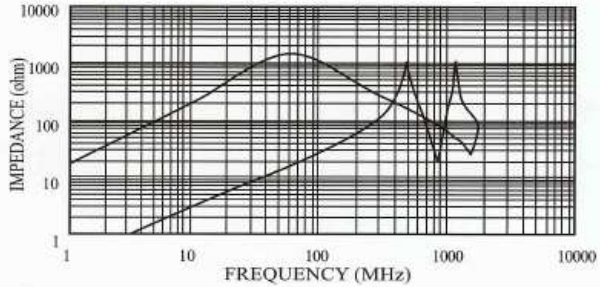

MOXIE MOX-CMF-5864-8

