

MOX-TRFH-EP7 SERIES



MoxiE[®]
INDUCTOR CORPORATION

High Frequency Wire Wound PoE Flyback Transformers (3W PoE)

- 8-pin (13.30mm X 10.70mm X 9.30mm) surface mount EP7 package.
- MoxiE custom designs available.
- Industrial operating temperature: -40°C to +85°C standard.
- Excellent solderability & resistance to soldering heat.
- Designed for power over ethernet (PoE).
- RoHS compliant.



NOTES

Blank lined area for notes.



MECHANICAL DIMENSIONS (mm)

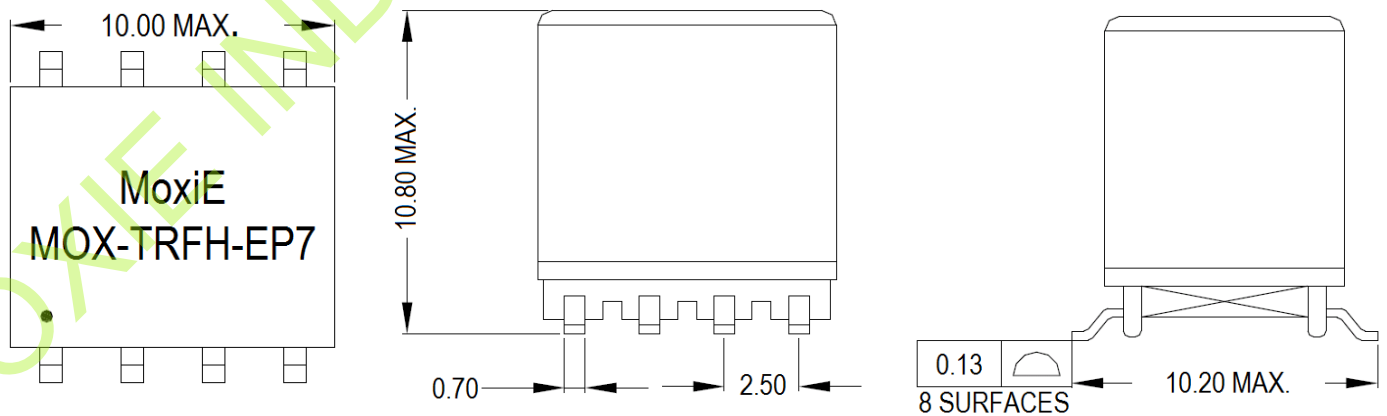



ELECTRICAL SPECIFICATIONS

MOXIE PART NUMBER	SPECIFICATIONS	TURNS RATIO			PRIMARY SECONDARY ISOLATION	PRIMARY INDUCTANCE ($\mu\text{H} \pm 10\%$)	LEAKAGE INDUCTANCE ($\mu\text{H MAX.}$)	DCR (m Ω MAXIMUM)			
		Pri.	Sec.	Pri-Aux.				Pri.	Pri. Aux.	Sec.A	Sec.B
MOX-TRFH-EP71	Vin=33-57v, Freq.=200kHz Vout=3.3v/3W, 8v/20mA	1	0.083	0.208	1500VRMS OPERATIONAL	500	7.50	1750	215	15	N/A
MOX-TRFH-EP72	Vin=33-57v, Freq.=200kHz Vout=3.3v/3W, 12v/20mA	1	0.128	0.682		310	5.00	1600	2600	45	N/A
MOX-TRFH-EP73	Vin=33-57v, Freq.=200kHz Vout=5.0v/3W, 8v/20mA	1	0.125	0.208		500	7.50	1750	215	35	N/A
MOX-TRFH-EP74	Vin=33-57v, Freq.=200kHz Vout=5.0v/3W, 12v/20mA	1	0.273	0.682		310	5.00	1600	2650	87	N/A
MOX-TRFH-EP75	Vin=33-57v, Freq.=200kHz Vout=12v/3W, 8v/20mA	1	0.286	0.204		521	7.50	1750	220	100	N/A
MOX-TRFH-EP76	Vin=33-57v, Freq.=200kHz Vout=12v/3W, 12v/20mA	1	0.682	0.682		310	5.00	1600	2600	550	N/A



LANDING PATTERN & SCHEMATIC

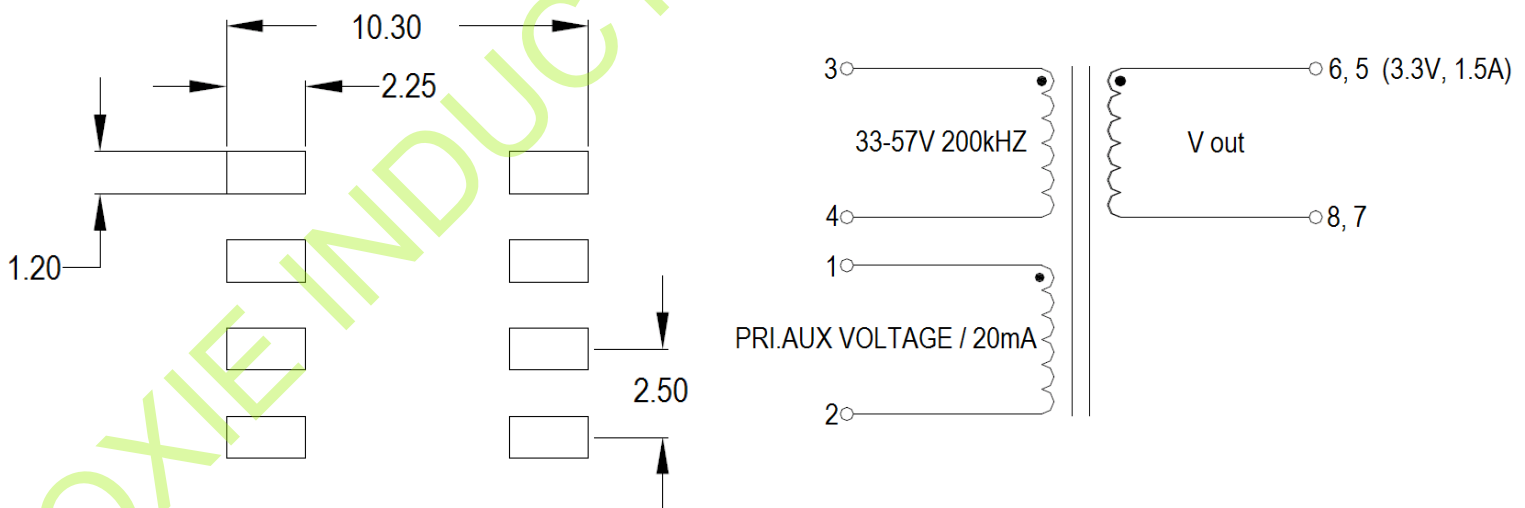

- MOXIE INDUCTOR CORPORATION SPECIFICATIONS ARE SUBJECT TO CHANGE WITHOUT NOTICE.
- MOXIE INDUCTOR CORPORATION CUSTOM DESIGNED PRODUCTS ARE SUBJECT TO UNITED STATES COPYRIGHT AND OR PATENT PROTECTION (S).
- CUSTOM DESIGNS AVAILABLE—PLEASE CONTACT YOUR MOXIE REPRESENTATIVE FOR DETAILS.