

# MOX-UPI-1511 SERIES

## Surface Mount High Current Unshielded Power Inductors

MoxiE's MOX-UPI-1511 series of surface mount high current power inductors are specially engineered for high current, low voltage DC-DC converter & LED driver applications. The industrial grade rugged design provides current ranges normally only available with larger packages.

### Features:

- Low cost.
- High current & low voltage.
- RoHS compliant.
- MoxiE Inductor corporation custom designs available.



## PART NUMBERS

MOXIE PART NUMBER	A (±)	B (±)	C (MAX.)	D (±)	E (±)	F (±)	G (REF.)	H (REF.)	I (REF.)
MOX-UPI-1511	15.00 ± 0.3	18.40 ± 0.3	11.50	2.40 ± 0.2	2.20 ± 0.2	13.30 ± 0.3	12.70	2.80	3.00



## MECHANICAL DIMENSIONS

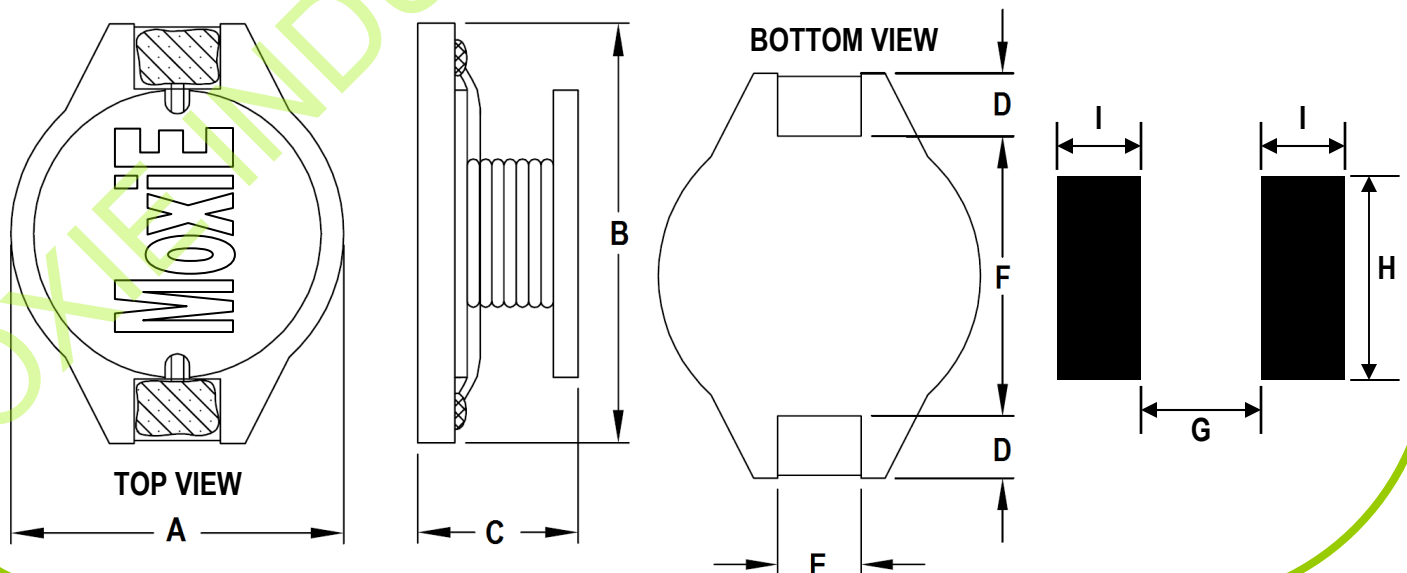

# MOX-UPI-1511 SERIES



## ELECTRICAL SPECIFICATIONS @ 25°C

MoxiE Part Number	Inductance (μH)	Tolerance (±)	Test Frequency	RDC (mΩ) Max.	IsAT (Amps)	Irms (Amps)
MOX-UPI-1511-470M	47.00	20%	1V/100KHz	54.00	5.40	3.80
MOX-UPI-1511-680M	68.00	20%	1V/100KHz	74.00	4.50	3.20
MOX-UPI-1511-101M	100.00	20%	1V/100KHz	123.00	6.80	2.60
MOX-UPI-1511-151M	150.00	20%	1V/100KHz	188.00	3.10	2.10
MOX-UPI-1511-221M	220.00	20%	1V/100KHz	278.00	2.60	1.70
MOX-UPI-1511-331M	330.00	20%	1V/100KHz	368.00	2.10	1.50
MOX-UPI-1511-471M	470.00	20%	1V/100KHz	505.00	1.70	1.25
MOX-UPI-1511-681M	680.00	20%	1V/100KHz	795.00	1.50	1.05
MOX-UPI-1511-102M	1000.00	20%	1V/100KHz	1100.00	1.20	0.85
MOX-UPI-1511-152M	1500.00	20%	1V/100KHz	1590.00	1.00	0.65
MOX-UPI-1511-222M	2200.00	20%	1V/100KHz	2250.00	0.85	0.55
MOX-UPI-1511-332M	3300.00	20%	1V/100KHz	3580.00	0.70	0.45
MOX-UPI-1511-472M	4700.00	20%	1V/100KHz	5190.00	0.60	0.40
MOX-UPI-1511-682M	6800.00	20%	1V/100KHz	7680.00	0.50	0.35
MOX-UPI-1511-103M	10000.00	20%	1V/100KHz	10900.00	0.40	0.30



## PACKAGING

MOXIE PART NUMBER	Packaging	Reel Size	Quantity Per Reel
MOX-UPI-1511	Tape & Reel	330 x 38.4	200

### MOXIE NOTES:

- Inductance instrument testing : HP4286A/CH1062A LCR meter.
- Inductance test condition: 100KHz @ 1KHz.
- DCR instrument testing: TH2512B or MoxiE equivalent DCR testing equipment.
- Rated current testing: VR7210 & VR113H.
- Rated current definition: Inductance drop by 25% or when temperature rises by 40°C (the lesser of the minimum as the rated current.)
- Operating temperature: -55°C to +125°C.
- Storage temperature: -55°C to +125°C.
- Resistance to solder heat: +260°C for 10 (ten) seconds.
- Moxie Inductor Corporation specifications are subject to change without notice.