

MOX-SPI-2D18H



High Current Surface Mount Shielded Inductors

MoxiE's SPI-2D18H series of surface mount shielded power inductors are widely used in PDA's, notebooks, LCD televisions and digital cameras. MoxiE offers a ultra low profile magnetically shielded package that offer high inductance & high power.

Features:

- High Current.
- Operating Temperature: -40°C to +85°C.
- Available Tolerances: $\pm 30\%$.
- RoHS Compliant.
- Magnetically Shielded Applications.



NOTES



MECHANICAL DIMENSIONS

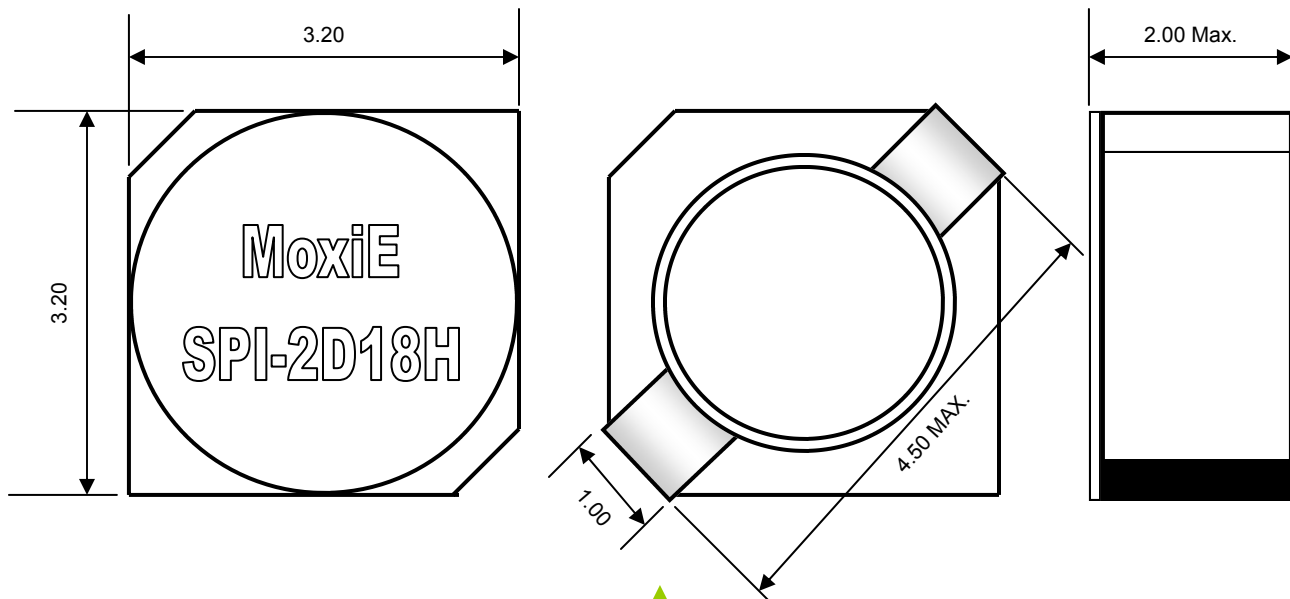



LANDING PATTERN & SCHEMATIC

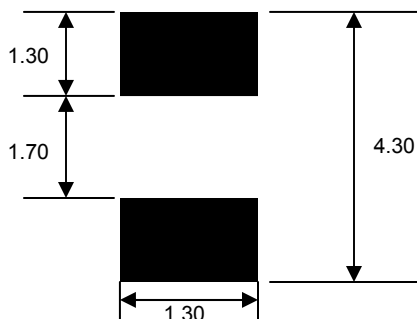
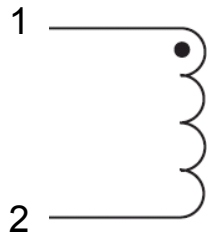

ELECTRICAL SPECIFICATIONS

Part Number	Inductance (μH)	Tolerance (%)	RDC (m Ω) Maximum	Rated Current (A)	L Test Frequency
MOX-SPI-2D18H-2R2T	1.70	30% (T)	44	1.88	100 kHz
MOX-SPI-2D18H-3R3T	2.20	30% (T)	60	1.62	100 kHz
MOX-SPI-2D18H-6R8T	3.30	30% (T)	86	1.47	100 kHz
MOX-SPI-2D18H-100T	4.70	30% (T)	140	1.22	100 kHz
MOX-SPI-2D18H-150T	6.30	30% (T)	160	1.08	100 kHz
MOX-SPI-2D18H-220T	10.00	30% (T)	245	0.89	100 kHz
MOX-SPI-2D18H-330T	15.00	30% (T)	345	0.72	100 kHz



ENGINEERING NOTES

- Rated current: The rated current indicates the current when the inductance decreases to 65% over its nominal value or D.C. current when the temperature rises $\Delta t=40^{\circ}\text{C}$.
- MoxiE test instruments: HP4192A LF impedance analyzer. RDC: CH502BC Rated current: HP4284+HP42841A or CH1061+CH301A
- Magnetically shielded to prevent noise radiation.
- MoxiE Inductor Corporation specifications are subject to change without notice.