

# MOX-SPI-0304

**MoxiE**  
INDUCTOR CORPORATION

## Surface Mount Shielded Power Inductors

MoxiE's SPI-0304 series of surface mount shielded inductors are engineered for portable DC-DC converter lines & industrial electronics. MoxiE offers an industry leading ultra low profile magnetically shielded package that offer high inductance & high power.

### Features:

- Miniature size, Mounting area: 3.2 x 3.2 Height: 2.0mm max.
- Low Cost.
- Operating Temperature: -40°C to +105°C. (including self temperature rise)
- Available Tolerances:  $\pm 20\%$  &  $\pm 30\%$ .
- RoHS Compliant.

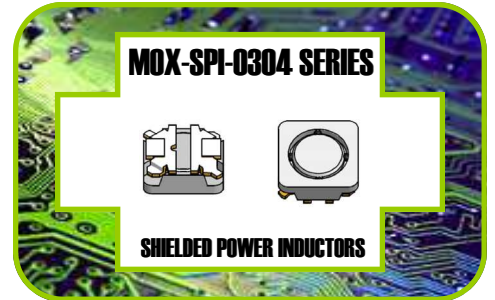

## NOTES

---

---

---

---

---

---

---

---

---

---



## MECHANICAL DIMENSIONS

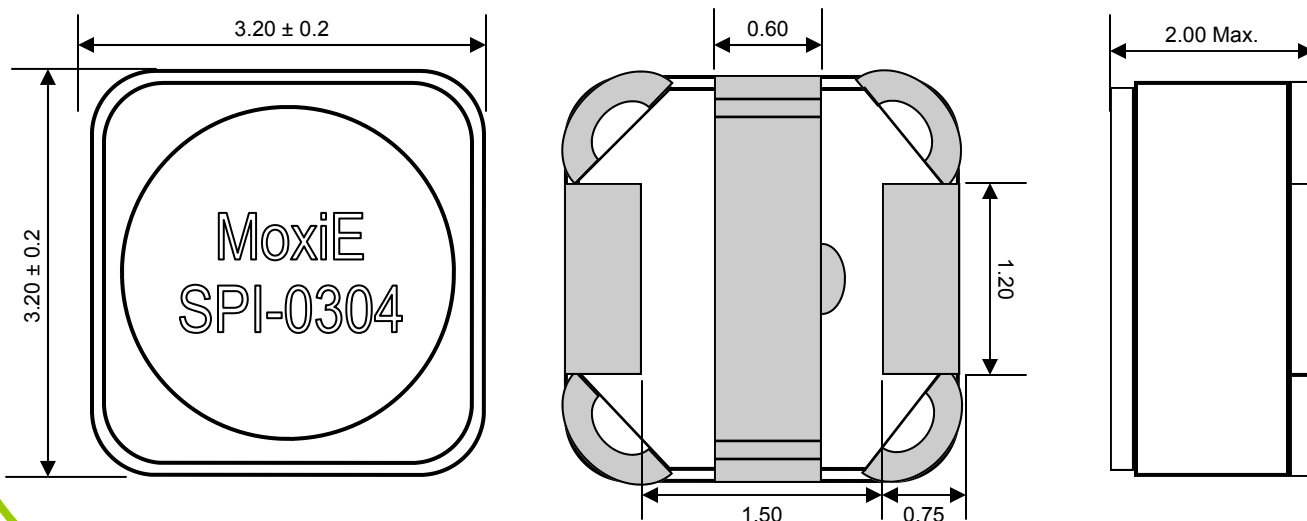

1



## LANDING PATTERN

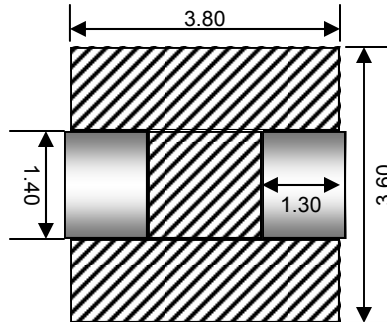

## ELECTRICAL SPECIFICATIONS

MoxiE Part Number	Inductance (µH)	Tolerance (%)	DCR (mΩ) Maximum	DCR (mΩ) Typical	IDC1 (A)	IDC2 (A)
MOX-SPI-0304-1R5N	1.50	30% (N)	95	76	1.80	1.45
MOX-SPI-0304-2R2N	2.20	30% (N)	106	84	1.50	1.33
MOX-SPI-0304-3R3N	3.30	30% (N)	125	100	1.30	1.24
MOX-SPI-0304-4R7N	4.70	30% (N)	157	126	1.00	1.10
MOX-SPI-0304-5R6N	5.60	30% (N)	180	144	0.92	1.00
MOX-SPI-0304-6R8N	6.80	30% (N)	193	154	0.88	0.94
MOX-SPI-0304-100M	10.00	20% (M)	241	193	0.78	0.77
MOX-SPI-0304-120M	12.00	20% (M)	322	258	0.63	0.68
MOX-SPI-0304-150M	15.00	20% (M)	344	275	0.60	0.66
MOX-SPI-0304-220M	22.00	20% (M)	445	356	0.48	0.57
MOX-SPI-0304-330M	33.00	20% (M)	649	519	0.40	0.52
MOX-SPI-0304-470M	47.00	20% (M)	924	739	0.32	0.41

### Rated Current:

IDC1: The value obtained DC current flows and the nominal value of inductance has fallen by 35%.

IDC2: The value obtained when current flows and the temperature has risen to 40°C.



## MOX-SPI-0304 ENGINEERING NOTES

- Available Tolerances: N= ±30%, M= ±20%,
- RoHS compliant
- Packaging: Tape & Reel.
- MoxiE Inductor Corporation specifications are subject to change without notice.