

MOX-SPL-SERIES

MoxiE[®]
INDUCTOR CORPORATION

Surface Mount Shielded Power Line Inductors

MoxiE's MOX-SPL series of surface mount shielded inductors are engineered for high current power line applications.

- Low cost.
- Magnetically shielded construction.
- Available in five different package types.
- Operating temperature: -40°C to +105°C.
- Excellent solderability & resistance to soldering heat.
- RoHS compliant.



PART NUMBERS

MOXIE PART NUMBER	A (MAX.)	B (MAX.)	H (HEIGHT)	D (REF.)	E (REF.)	F (REF.)
MOX-SPL-3310	3.30	2.80	0.90	2.20	0.25	0.80
MOX-SPL-4020	4.80	4.30	2.00	2.70	0.50	1.60
MOX-SPL-5018	5.80	5.30	1.80	4.20	0.60	1.60
MOX-SPL-5022	5.80	5.30	2.00	4.20	0.60	1.60
MOX-SPL-5030	5.80	5.30	3.00	4.20	0.60	1.60



MECHANICAL DIMENSIONS

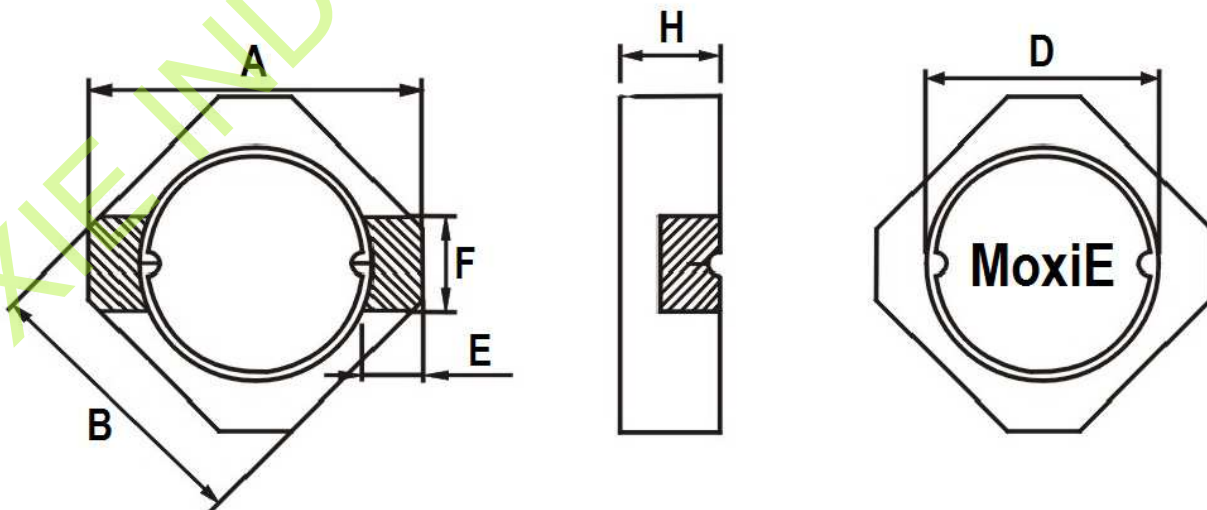



ELECTRICAL SPECIFICATIONS

MoxiE Part Number	Inductance (μH)	Tolerance (%)	DC Resistance (Ω) Max.	Rated Current (A) Max.	Test Condition
MOX-SPL-3310-1R0N	1.0	±30	0.125	1.68	100KHz/0.1V
MOX-SPL-3310-1R5N	1.5	±30	0.122	1.65	100KHz/0.1V
MOX-SPL-3310-2R2N	2.2	±30	0.282	1.15	100KHz/0.1V
MOX-SPL-3310-3R3N	3.3	±30	0.325	0.98	100KHz/0.1V
MOX-SPL-3310-4R7N	4.7	±30	0.525	0.85	100KHz/0.1V
MOX-SPL-3310-5R6N	5.6	±30	0.552	0.77	100KHz/0.1V
MOX-SPL-3310-6R8N	6.8	±30	0.602	0.58	100KHz/0.1V
MOX-SPL-3310-8R2N	8.2	±30	0.725	0.53	100KHz/0.1V
MOX-SPL-3310-100N	10.0	±30	0.824	0.47	100KHz/0.1V
MOX-SPL-3310-120N	12.0	±30	1.252	0.44	100KHz/0.1V
MOX-SPL-3310-150N	15.0	±30	2.184	0.40	100KHz/0.1V
MOX-SPL-3310-220N	22.0	±30	2.801	0.35	100KHz/0.1V
MOX-SPL-3310-330N	33.0	±30	4.224	0.30	100KHz/0.1V
MOX-SPL-3310-470N	47.0	±30	5.544	0.27	100KHz/0.1V

MoxiE Part Number	Inductance (μH)	Tolerance (%)	DC Resistance (Ω) Max.	Rated Current (A) Max.	Test Condition
MOX-SPL-4020-150M	15.0	±20	0.480	0.65	100KHz/0.1V
MOX-SPL-4020-220M	22.0	±20	0.710	0.54	100KHz/0.1V
MOX-SPL-4020-330M	33.0	±20	1.010	0.47	100KHz/0.1V
MOX-SPL-4020-470M	47.0	±20	1.750	0.38	100KHz/0.1V
MOX-SPL-4020-680M	68.0	±20	2.750	0.28	100KHz/0.1V
MOX-SPL-4020-101M	100.0	±20	3.420	0.21	100KHz/0.1V

MoxiE Part Number	Inductance (μH)	Tolerance (%)	DC Resistance (Ω) Max.	Rated Current (A) Max.	Test Condition
MOX-SPL-5018-1R2M	1.2	±20	0.051	1.90	100KHz/0.1V
MOX-SPL-5018-1R8M	1.8	±20	0.062	1.70	100KHz/0.1V
MOX-SPL-5018-2R3M	2.3	±20	0.074	1.60	100KHz/0.1V
MOX-SPL-5018-3R6M	3.6	±20	0.092	1.30	100KHz/0.1V
MOX-SPL-5018-4R3M	4.3	±20	0.110	1.20	100KHz/0.1V
MOX-SPL-5018-5R1M	5.1	±20	0.120	1.10	100KHz/0.1V
MOX-SPL-5018-6R8M	6.8	±20	0.140	0.98	100KHz/0.1V
MOX-SPL-5018-100M	10.0	±20	0.210	0.88	100KHz/0.1V
MOX-SPL-5018-150M	15.0	±20	0.310	0.67	100KHz/0.1V
MOX-SPL-5018-180M	18.0	±20	0.350	0.68	100KHz/0.1V
MOX-SPL-5018-220M	22.0	±20	0.510	0.51	100KHz/0.1V
MOX-SPL-5018-330M	33.0	±20	0.740	0.45	100KHz/0.1V
MOX-SPL-5018-470M	47.0	±20	1.100	0.37	100KHz/0.1V



ELECTRICAL SPECIFICATIONS

MoxiE Part Number	Inductance (μ H)	Tolerance (%)	DC Resistance (Ω) Max.	Rated Current (A) Max.	Test Condition
MOX-SPL-5022-1R2M	1.2	± 20	0.027	4.20	100KHz/0.1V
MOX-SPL-5022-1R8M	1.8	± 20	0.032	3.60	100KHz/0.1V
MOX-SPL-5022-2R2M	2.2	± 20	0.038	3.20	100KHz/0.1V
MOX-SPL-5022-3R3M	3.3	± 20	0.050	2.50	100KHz/0.1V
MOX-SPL-5022-3R5M	3.5	± 20	0.060	2.30	100KHz/0.1V
MOX-SPL-5022-4R7M	4.7	± 20	0.081	2.00	100KHz/0.1V
MOX-SPL-5022-6R8M	6.8	± 20	0.102	1.60	100KHz/0.1V
MOX-SPL-5022-100M	10.0	± 20	0.150	1.40	100KHz/0.1V
MOX-SPL-5022-150M	15.0	± 20	0.200	1.10	100KHz/0.1V
MOX-SPL-5022-220M	22.0	± 20	0.320	0.90	100KHz/0.1V
MOX-SPL-5022-330M	33.0	± 20	0.445	0.65	100KHz/0.1V
MOX-SPL-5022-470M	47.0	± 20	0.720	0.42	100KHz/0.1V
MOX-SPL-5022-680M	68.0	± 20	0.910	0.36	100KHz/0.1V
MOX-SPL-5022-101M	100.0	± 20	1.400	0.27	100KHz/0.1V

MoxiE Part Number	Inductance (μ H)	Tolerance (%)	DC Resistance (Ω) Max.	Rated Current (A) Max.	Test Condition
MOX-SPL-5030-1R1M	1.1	± 20	0.020	4.60	100KHz/0.1V
MOX-SPL-5030-2R0M	2.0	± 20	0.075	3.40	100KHz/0.1V
MOX-SPL-5030-3R3M	3.3	± 20	0.032	2.60	100KHz/0.1V
MOX-SPL-5030-4R7M	4.7	± 20	0.044	2.20	100KHz/0.1V
MOX-SPL-5030-6R8M	6.8	± 20	0.065	1.92	100KHz/0.1V
MOX-SPL-5030-100M	10.0	± 20	0.089	1.65	100KHz/0.1V
MOX-SPL-5030-150M	15.0	± 20	0.135	1.47	100KHz/0.1V
MOX-SPL-5030-220M	22.0	± 20	0.205	1.16	100KHz/0.1V
MOX-SPL-5030-330M	33.0	± 20	0.245	0.94	100KHz/0.1V
MOX-SPL-5030-470M	47.0	± 20	0.334	0.74	100KHz/0.1V
MOX-SPL-5030-680M	68.0	± 20	0.514	0.58	100KHz/0.1V
MOX-SPL-5030-101M	100.0	± 20	0.793	0.53	100KHz/0.1V

MOXIE ENGINEERING NOTES:

- MOXIE INDUCTOR CORPORATION CUSTOM INDUCTANCE VALUES AVAILABLE.—CONTACT MOXIE FOR SPECIAL REQUESTS.
- OPERATING TEMPERATURE: -40°C TO $+105^{\circ}\text{C}$. (INCLUDING SELF TEMPERATURE RISE.)
- RATED CURRENT: VALUE OBTAINED WHEN CURRENT FLOWS AND THE TEMPERATURE HAS RISEN TO $+40^{\circ}\text{C}$ OR WHEN THE DC CURRENT FLOWS AND THE NOMINAL VALUE OF INDUCTANCE HAS FALLEN BY 30% WHICHEVER IS LESS.
- RoHS COMPLIANT.
- MOXIE INDUCTOR CORPORATION SPECIFICATIONS ARE SUBJECT TO CHANGE WITHOUT NOTICE.
- MOXIE INDUCTOR CORPORATION CUSTOM DESIGNED PRODUCT(S) ARE SUBJECT TO UNITED STATES PATENT AND OR COPYRIGHT PROTECTION(S).



LANDING PATTERN

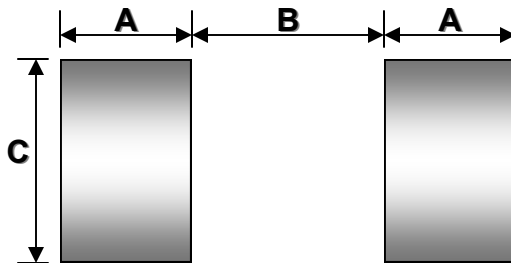

MOXIE PART NUMBER	A	B	C
MOX-SPL-3310	0.40	2.30	1.00
MOX-SPL-4020	0.70	2.50	1.80
MOX-SPL-5018	0.80	4.00	1.80
MOX-SPL-5022	0.80	4.00	1.80
MOX-SPL-5030	0.80	4.00	1.80



PACKAGING

MOXIE PART NUMBER	REEL SIZE	QUANTITY
MOX-SPL-3310	330mm	3000
MOX-SPL-4020	330mm	3000
MOX-SPL-5018	330mm	3000
MOX-SPL-5022	330mm	3000
MOX-SPL-5030	330mm	2500

MOXIE ENGINEERING NOTES:

- MOXIE INDUCTOR CORPORATION CUSTOM INDUCTANCE VALUES AVAILABLE.—CONTACT MOXIE FOR SPECIAL REQUESTS.
- OPERATING TEMPERATURE: -40°C TO +105°C. (INCLUDING SELF TEMPERATURE RISE.)
- RATED CURRENT: VALUE OBTAINED WHEN CURRENT FLOWS AND THE TEMPERATURE HAS RISEN TO +40°C OR WHEN THE DC CURRENT FLOWS AND THE NOMINAL VALUE OF INDUCTANCE HAS FALLEN BY 30% WHICHEVER IS LESS.
- RoHS COMPLIANT.
- MOXIE INDUCTOR CORPORATION SPECIFICATIONS ARE SUBJECT TO CHANGE WITHOUT NOTICE.
- MOXIE INDUCTOR CORPORATION CUSTOM DESIGNED PRODUCT(S) ARE SUBJECT TO UNITED STATES PATENT AND OR COPYRIGHT PROTECTION(S).