



TAI-SAW TECHNOLOGY CO., LTD.

No. 3, Industrial 2nd Rd., Ping-Chen Industrial District,
Taoyuan, 324, Taiwan, R.O.C.

TEL: 886-3-4690038 FAX: 886-3-4697532

E-mail: tstsales@mail.taisaw.com Web: www.taisaw.com

Approval Sheet For Product Specification

Issued Date:

Product Name: SAW Resonator 804.931 MHz SMD 3.8X3.8 mm

TST Parts No.: TC0178A

Customer Parts No.: _____

Company: _____
Division: _____
Approved by : _____
Date: _____

Checked by: Vincent Liu

Approval by: Francis Chen

Date: 2002/11/12



TAI-SAW TECHNOLOGY CO., LTD.

No. 3, Industrial 2nd Rd., Ping-Chen Industrial District,
Taoyuan, 324, Taiwan, R.O.C.

TEL: 886-3-4690038 FAX: 886-3-4697532

E-mail: tstsales@mail.taisaw.com Web: www.taisaw.com

SAW Resonator 804.931 MHz

MODEL NO.: TC0178A

REV. NO.:3

A. FEATURES:

1. 1-Port Resonator.

B. MAXIMUM RATING:

1. Input Power Level: 0 dBm

2. DC voltage: 12 V

3. Operating Temperature: -40°C to +85°C

4. Storage Temperature: -40°C to +85°C

C. ELECTRICAL CHARACTERISTICS:

Characteristic	Units	Minimum	Typical	Maximum
Center frequency Fr	MHz	804.806	804.931	805.056
Insertion Loss IL	dB	-	1.5	2.5
Equivalent Elements				
Motional capacitance C1	fF	-	1.74	-
Motional inductance L1	μH	-	22.4	-
Motional resistance R1	Ohm	-	13.9	33
Parallel capacitance Co	pF	-	2.88	-
Temp.coeff.	ppm/c*2	-	0.032	-
Turnover To	deg.C	20	-	50
Package size		SMD 3.8X3.8X1.4mm		

RoHS Compliant
Lead free
Lead-free soldering

D. OUTLINE DRAWING:

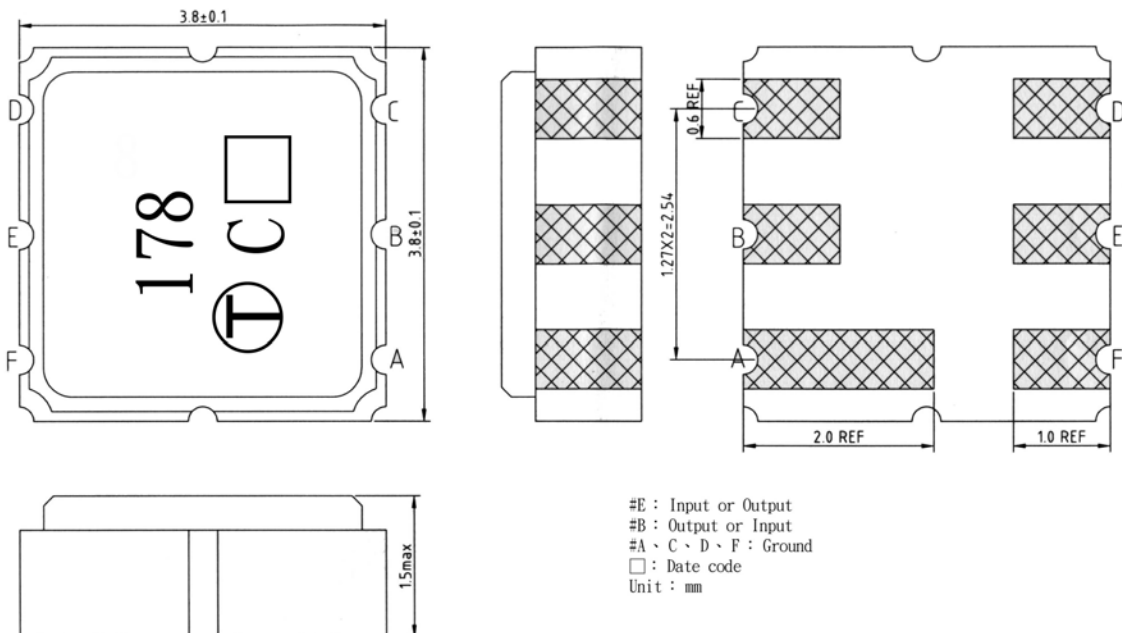

E. EQUIVARENT CIRCUIT:

One-Port Resonator:

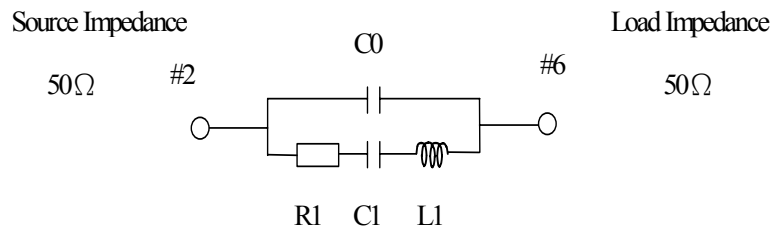

F. FREQUENCY CHARACTERISTICS:

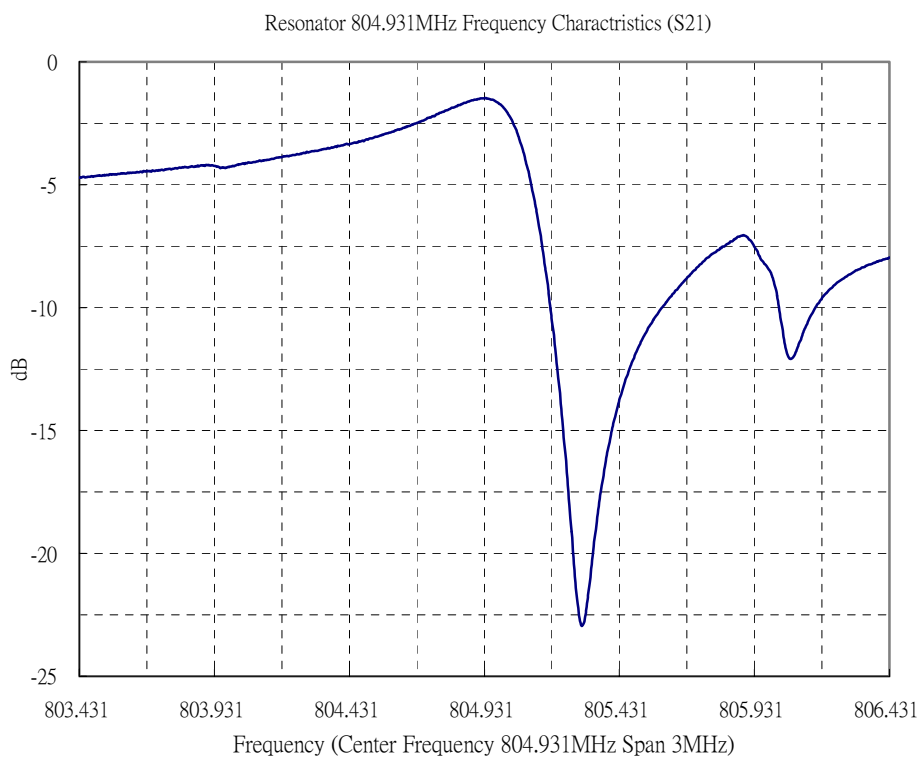

G. TEST CIRCUIT:

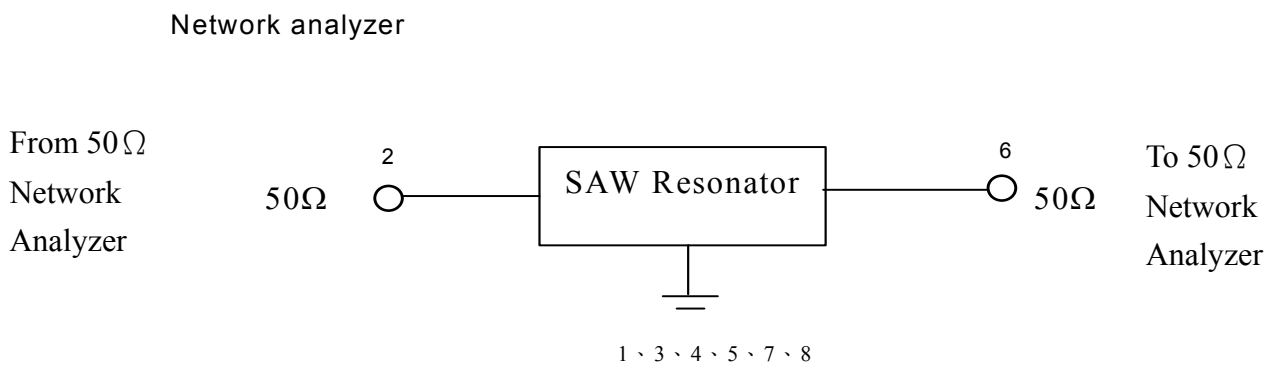

H. PACKING:

1. REEL DIMENSION

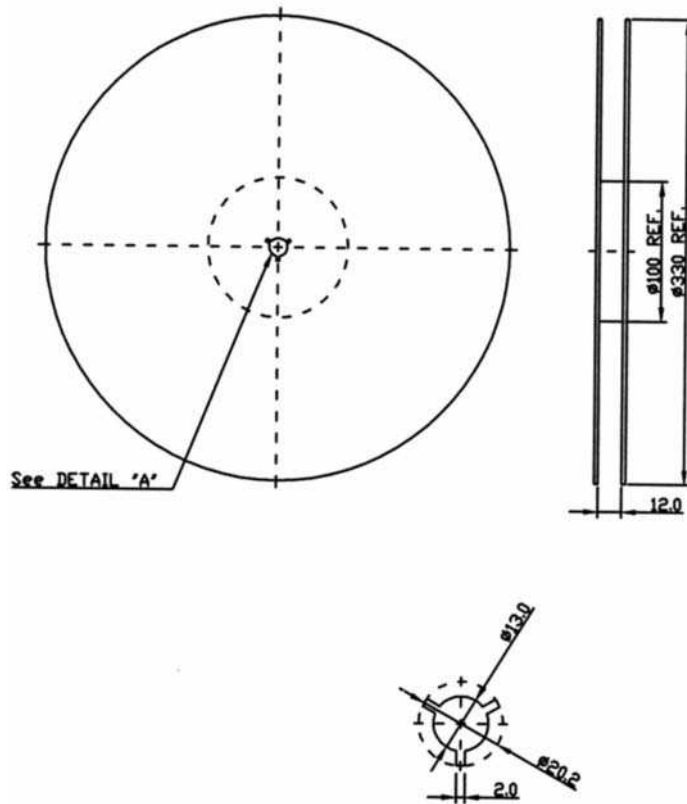

2. TAPE DIMENSION

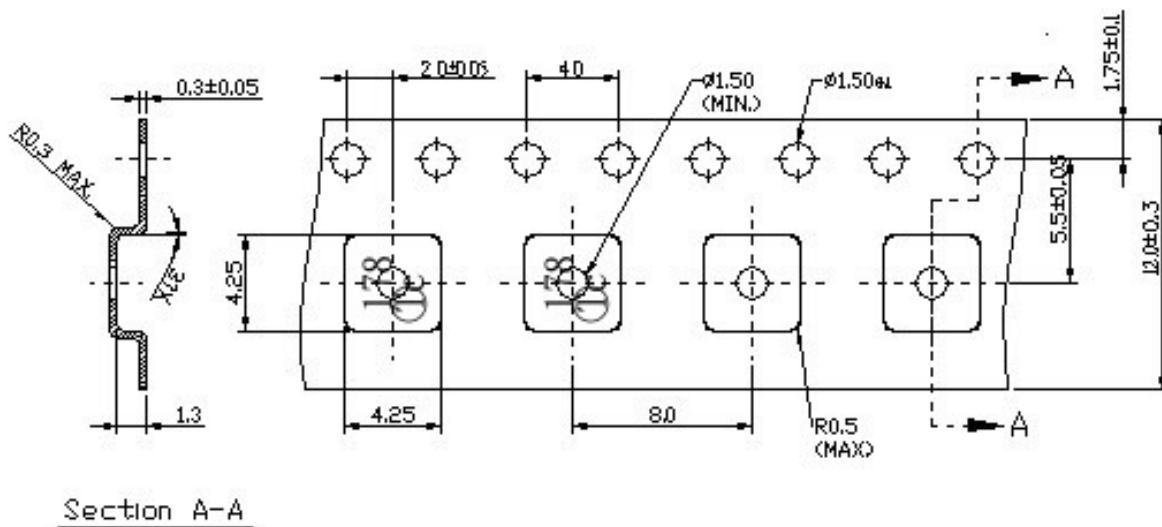

Section A-A