

## FEATURES

- Output Switch Current In Excess of 1.5A
- 2% Reference Accuracy
- Low Quiescent Current : 2.5mA(Typ.)
- Operating From 3V to 40V
- Frequency Operation to 100KHz
- Active Current Limiting
- Moisture Sensitivity Level 3D
- MC34063AG is Halogen Free Products

## APPLICATION

- Battery Chargers
- NICs / Switches / Hubs
- ADSL Modems
- Negative Voltage Power Supplies

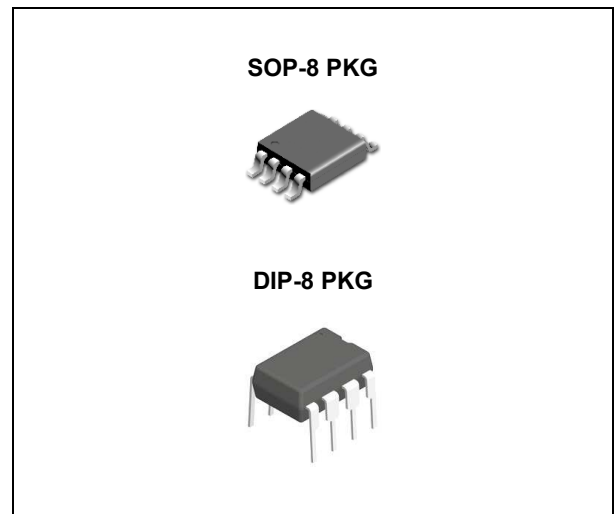

## ORDERING INFORMATION

Device	Package
MC34063AD	SOP-8
MC34063AGD	
MC34063BD	
MC34063AN	DIP-8

## DESCRIPTION

The MC34063A/B series is a monolithic control circuit delivering the main functions for DC-DC voltage converting. The device contains an internal temperature compensated reference, comparator, duty cycle controlled oscillator with an active current limit circuit driver and high current output switch.

Output voltage is adjustable through two external resistors with a 2% reference accuracy.

Employing a minimum number of external components the MC34063A/B devices series is designed for Step-Down, Step-Up and Voltage-Inverting applications.

## Absolute Maximum Ratings <sup>(Note 1)</sup>

CHARACTERISTIC	SYMBOL	MIN.	MAX.	UNIT
Power Supply Voltage	$V_{CC}$	-	50	V
Comparator Input Voltage Range	$V_{IR}$	-0.3	40	V
Switch Collector Voltage	$V_{SWC}$		40	V
Switch Emitter Voltage( $V_{SWC}=40V$ )	$V_{SWE}$		40	V
Switch Collector to Emitter Voltage	$V_{CE}$		40	V
Driver Collector Voltage	$V_{dc}$	-	40	V
Driver Collector Current <sup>(Note 2)</sup>	$I_{dc}$	-	100	mA
Switch Current	$I_{SW}$	-	1.5	A

## Absolute Maximum Ratings (Continued)

CHARACTERISTIC		SYMBOL	MIN.	MAX.	UNIT
Power Dissipation (at $T_A = 25^\circ\text{C}$ )	SOP-8	$PD_{MAX\_SOP-8}$		1.250	W
	DIP-8	$PD_{MAX\_DIP-8}$		0.625	W
Thermal Resistance	SOP-8	$\theta_{JA-SOP-8}$		100	$^\circ\text{C/W}$
	DIP-8	$\theta_{JA-DIP-8}$		160	$^\circ\text{C/W}$
Operating Junction Temperature Range		$T_J$	-40	150	$^\circ\text{C}$
Operating Ambient Temperature Range	MC34063A	$T_{AOPR}$	0	75	$^\circ\text{C}$
	MC34063B		-40	85	$^\circ\text{C}$
Storage Temperature Range		$T_{STG}$	-65	150	$^\circ\text{C}$

Note 1. Absolute Maximum Ratings are those values beyond which damage to the device may occur. Functional operation under these conditions is not implied.

## THERMAL DATA

SYMBOL	PARAMETER	DIP-8	SOP-8	UNIT
$R_{THJ-AMB}$	Thermal Resistance Junction-Ambient(*) Max	100	160	$^\circ\text{C/W}$

(\*) This value depends from thermal design of PCB on which the device is mounted.

## Ordering Information

Operating Ambient Temperature( $T_{AOPR}$ ) Range	Package	Order No.	Supplied As	Status
$0^\circ\text{C} \sim 70^\circ\text{C}$	SOP8	MC34063AD	Reel	Active
$0^\circ\text{C} \sim 70^\circ\text{C}$		MC34063AGD	Reel	Contact us
$-40^\circ\text{C} \sim 85^\circ\text{C}$		MC34063BD	Reel	Active
$0^\circ\text{C} \sim 70^\circ\text{C}$	DIP8	MC34063AN	Tube	Active
$-40^\circ\text{C} \sim 85^\circ\text{C}$		MC34063BN	Tube	Active

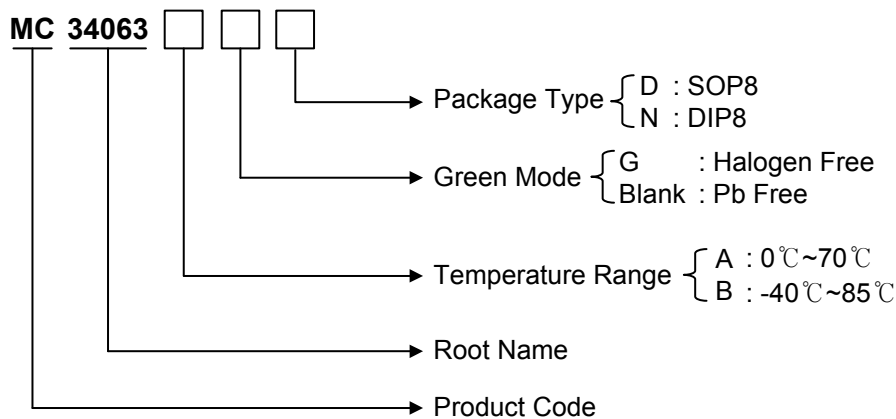

## PIN CONFIGURATION

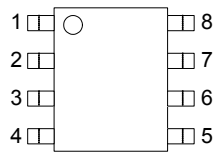

SOP-8

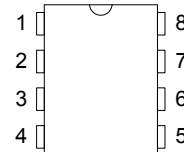

DIP-8

## PIN DESCRIPTION

Pin No.	SOP-8 / DIP-8 PKG	
	Name	Function
1	Switch Collector	Internal switch transistor collector
2	Switch Emitter	Internal switch transistor emitter
3	Timing Capacitor	Timing Capacitor to control the switching frequency
4	GND	Ground pin for all internal circuits
5	Comparator Inverting Input	Inverting input pin for internal comparator
6	V <sub>CC</sub>	Voltage supply
7	I <sub>PK</sub> Sense	Peak Current Sense Input by monitoring the voltage drop across an external I sense resistor to limit the peak current through the switch
8	Driver Collector	Voltage driver collector

## BLOCK DIAGRAM

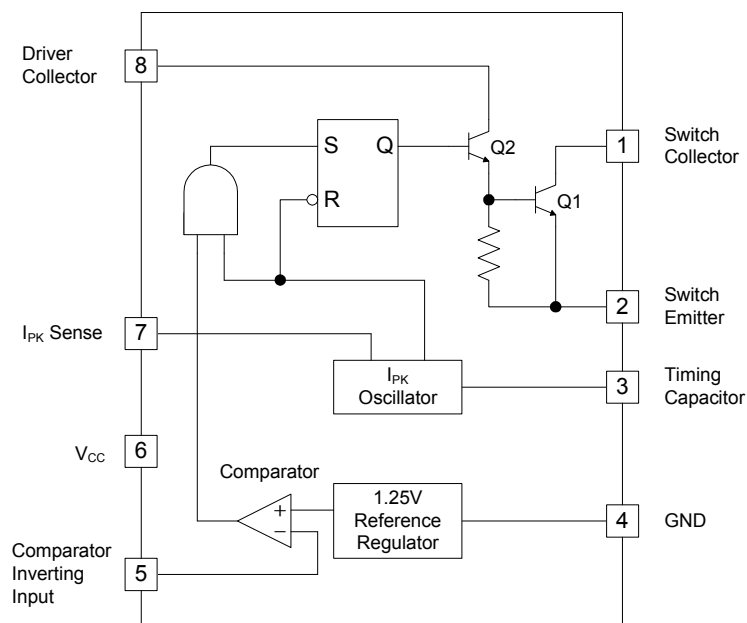

## ELECTRICAL CHARACTERISTICS

(Refer to the test circuits,  $V_{CC}=5V$ ,  $T_A=T_{LOW}$  to  $T_{HIGH}$ , unless otherwise specified, see note 2)

SYMBOL	PARAMETER	TEST CONDITIONS	MIN.	TYP.	MAX.	UNIT
<b>OSCILLATOR</b>						
$F_{OSC}$	Frequency	$V_{PIN5}=0V$ , $C_T=1nF$ , $T_A=25^\circ C$	24	33	42	KHz
$I_{CHG}$	Charge Current	$V_{CC}=5$ to $40V$ , $T_A=25^\circ C$	24	35	42	$\mu A$
$I_{DISCHG}$	Discharge Current	$V_{CC}=5$ to $40V$ , $T_A=25^\circ C$	140	220	260	$\mu A$
$I_{DISCHG}/I_{CHG}$	Discharge to Charge Current Ratio	Pin 7 = $V_{CC}$ , $T_A=25^\circ C$	5.2	6.5	7.5	
$V_{IPK(SENSE)}$	Current Limit Sense Voltage	$I_{CHG}=I_{DISCHG}$ , $T_A=25^\circ C$	250	300	350	mV
<b>OUTPUT SWITCH</b>						
$V_{CE(SAT)}$	Saturation Voltage, Darlington connection	$I_{SW}=1A$ , Pins 1,8 connected		1.0	1.3	V
$V_{CE(SAT)}$	Saturation Voltage	$I_{SW}=1A$ , $R_{PIN8}=82\Omega$ to $V_{CC}$ , Forced $\beta \sim 20$		0.45	0.7	V
$h_{FE}$	DC Current Gain	$I_{SW}=1A$ , $V_{CE}=5V$ , $T_A=25^\circ C$	50	75		
$I_{C(OFF)}$	Collector Off-State Current	$V_{CE}=40V$		0.01	100	$\mu A$
<b>COMPARATOR</b>						
$V_{TH}$	Threshold Voltage	$T_A=25^\circ C$	1.225	1.25	1.275	V
		$T_A=T_{LOW}$ to $T_{HIGH}$	1.21		1.29	V
$REG_{LINE}$	Threshold Voltage Line Regulation	$V_{CC}=3$ to $40V$		1	5	mV
$I_{IB}$	Input Bias Current	$V_{IN}=0V$		-5	-400	nA
<b>TOTAL DEVICE</b>						
$I_{CC}$	Supply Current	$V_{CC}=5$ to $40V$ , $C_T=1nF$ Pin7 = $V_{CC}$ , $V_{PIN5}>V_{TH}$ , Pin2=GND Remaining pins open for MC34063A/B		1.4	4	mA

Note 1. Maximum package power dissipation limit must be observed.

Note 2.  $T_{LOW} = -30^\circ C$ ,  $T_{HIGH} = +125^\circ C$ 

Note 3. If Darlington configuration is not used, care must be taken to avoid deep saturation of output switch.

The resulting switch-off time may be adversely affected.

In a Darlington configuration the following output driver condition is suggested:

$$\text{Forced } \beta \text{ of output switch : } \frac{I_{C(OUTPUT)}}{I_{C(DRIVER)} - 7.0mA} \geq 10$$

\* Currentless due to a built in  $1K\Omega$  anti-leakage resistor

TYPICAL ELECTRICAL CHARACTERISTICS

Emitter Follower Configuration Output

Saturation Voltage vs. Emitter Current

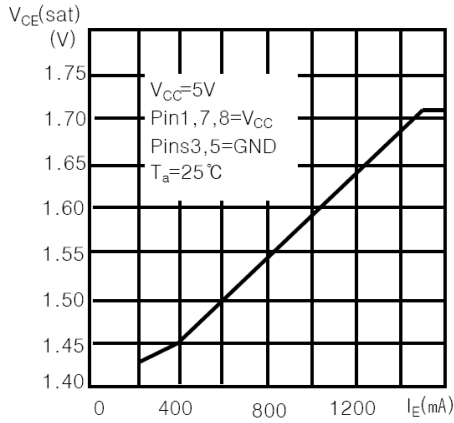

Output Switch ON-OFF Time

vs. Oscillator Timing Capacitor

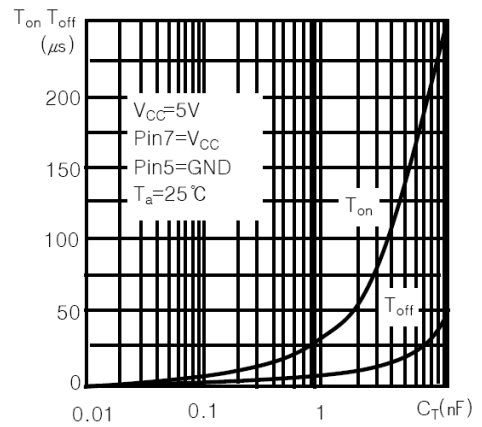

Common Emitter Configuration Output Switch

Saturation Voltage vs. Collector Current

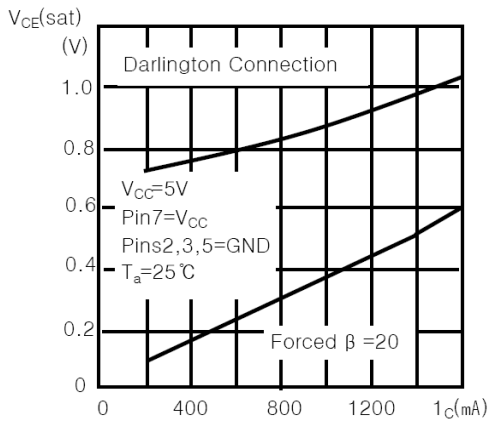

Darlington Configuration Collector Emitter

Saturation Voltage ( $V_{CE(SAT)}$ ) vs. Temperature

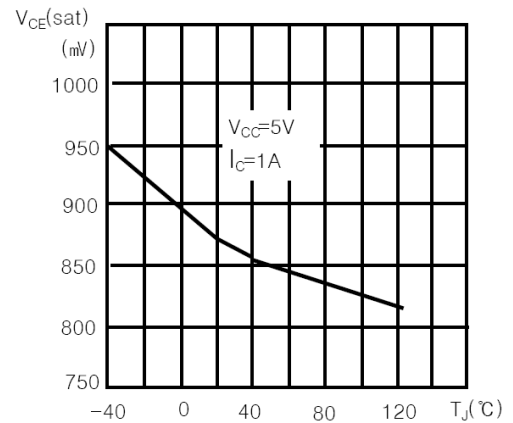

Power Collector Emitter Saturation

Voltage ( $V_{CE(SAT)}$ ) vs. Temperature

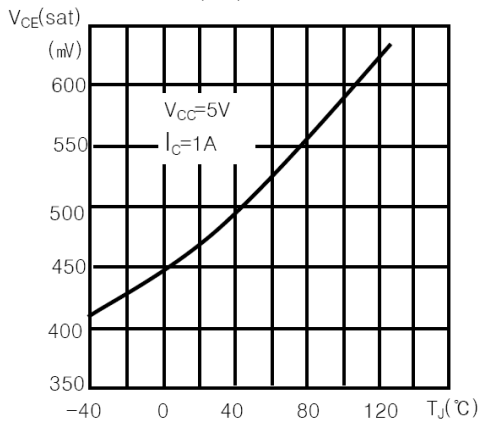

Current Limit Sense Voltage ( $V_{IPK}$ )

vs. Temperature

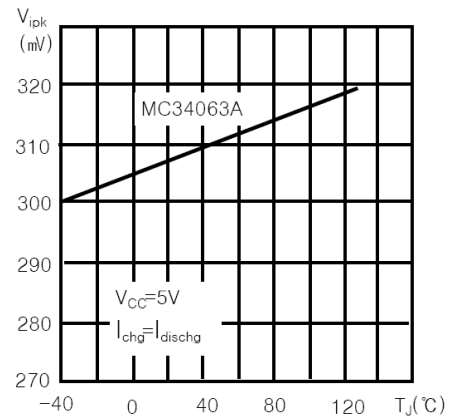

TYPICAL ELECTRICAL CHARACTERISTICS (Continued)

Reference Voltage vs. Temperature

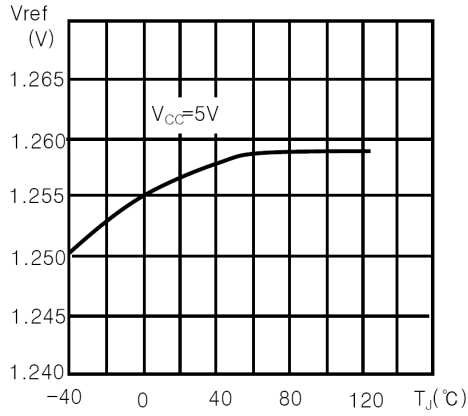

Bias Current vs. Temperature

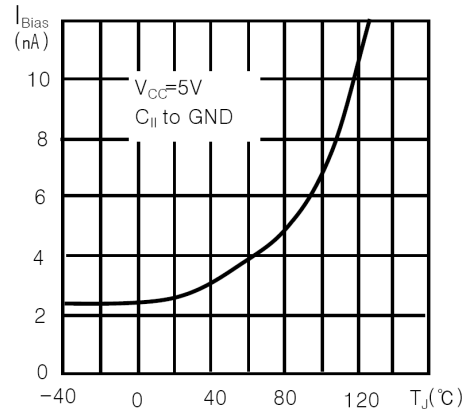

Supply Current vs. Temperature

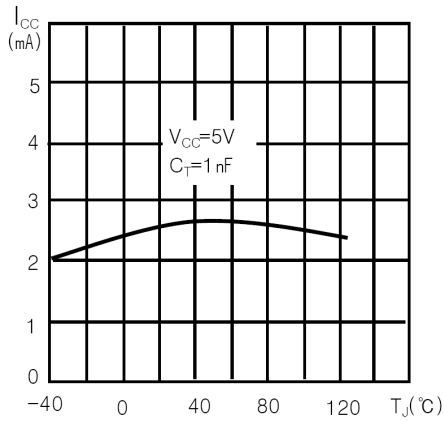

Supply Current vs. Input Voltage

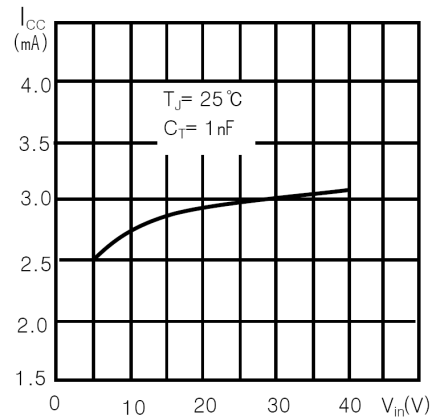

## TYPICAL APPLICATION CIRCUIT

### Step-Up Converter

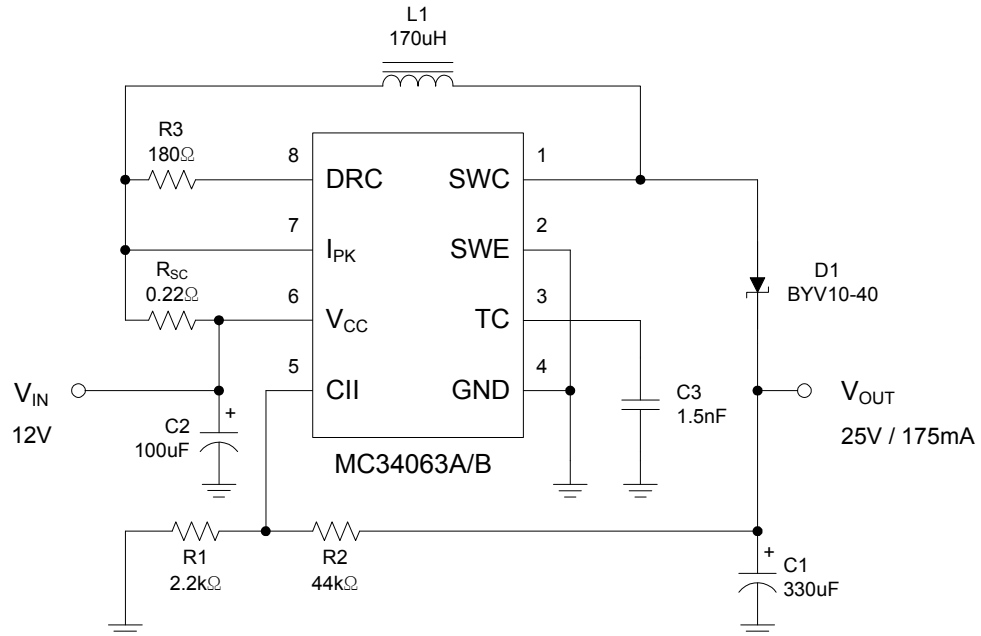

### Step-Down Converter

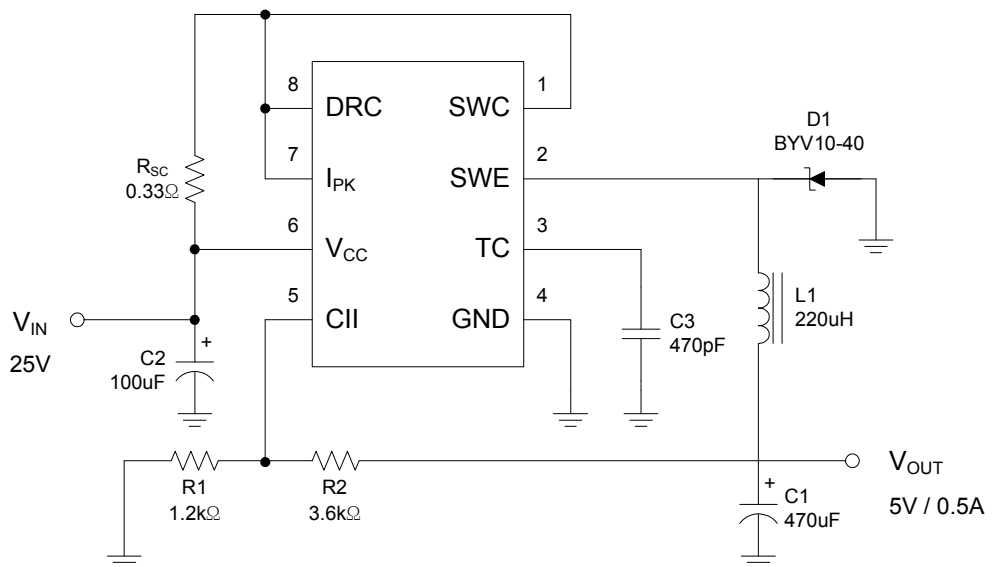

Step-Up with External NPN Switch

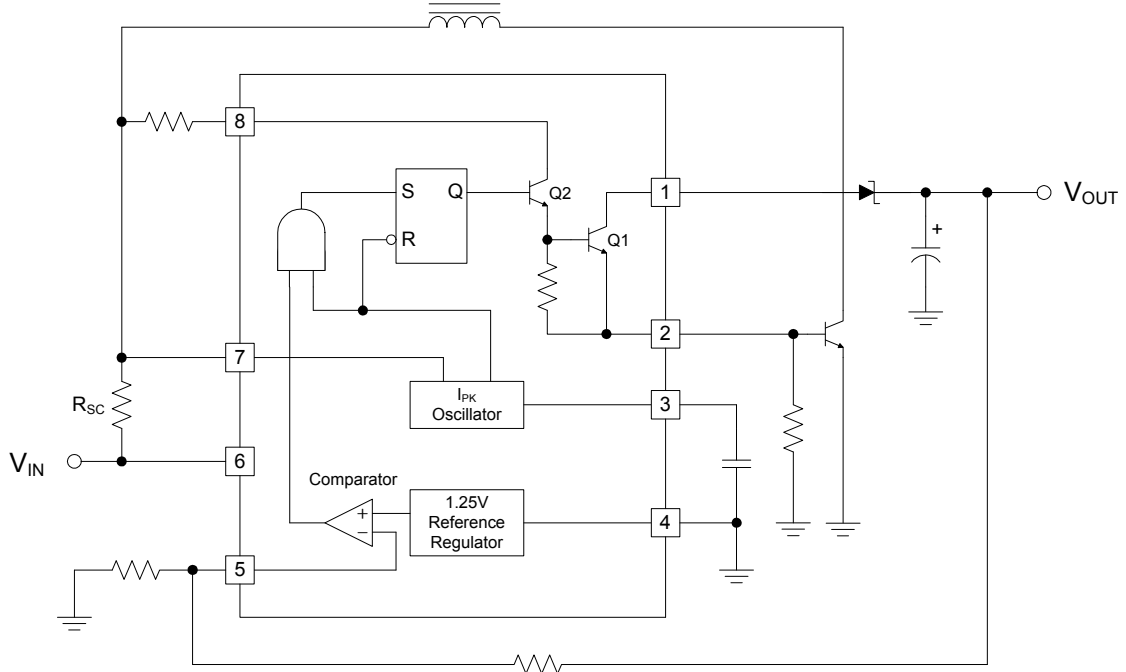

Voltage Inverting Converter

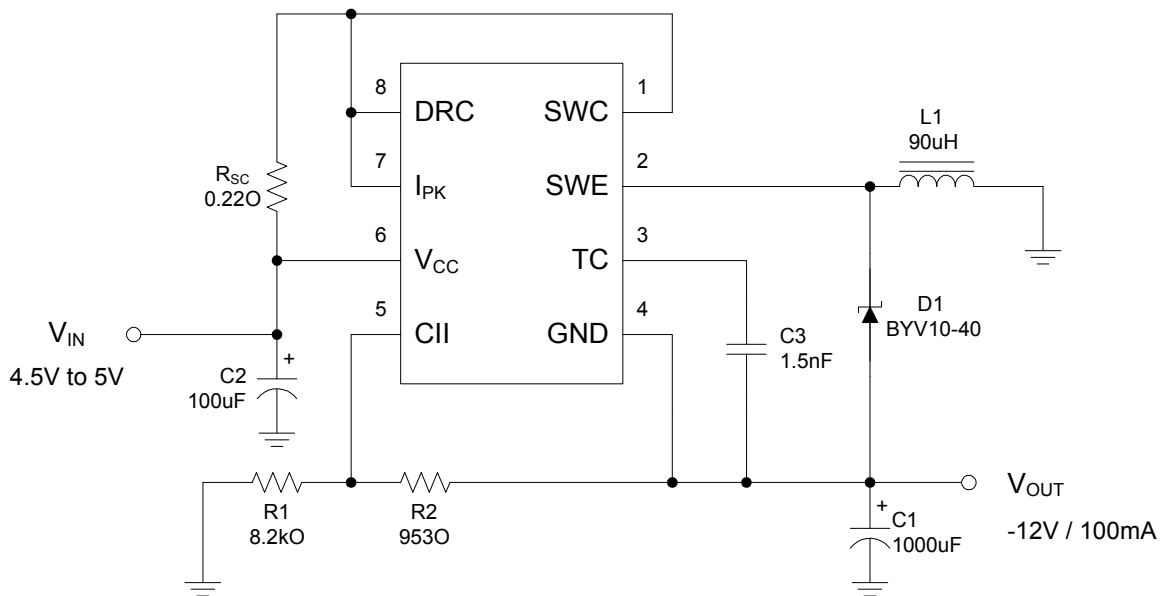



## Step-Down with External NPN Switch

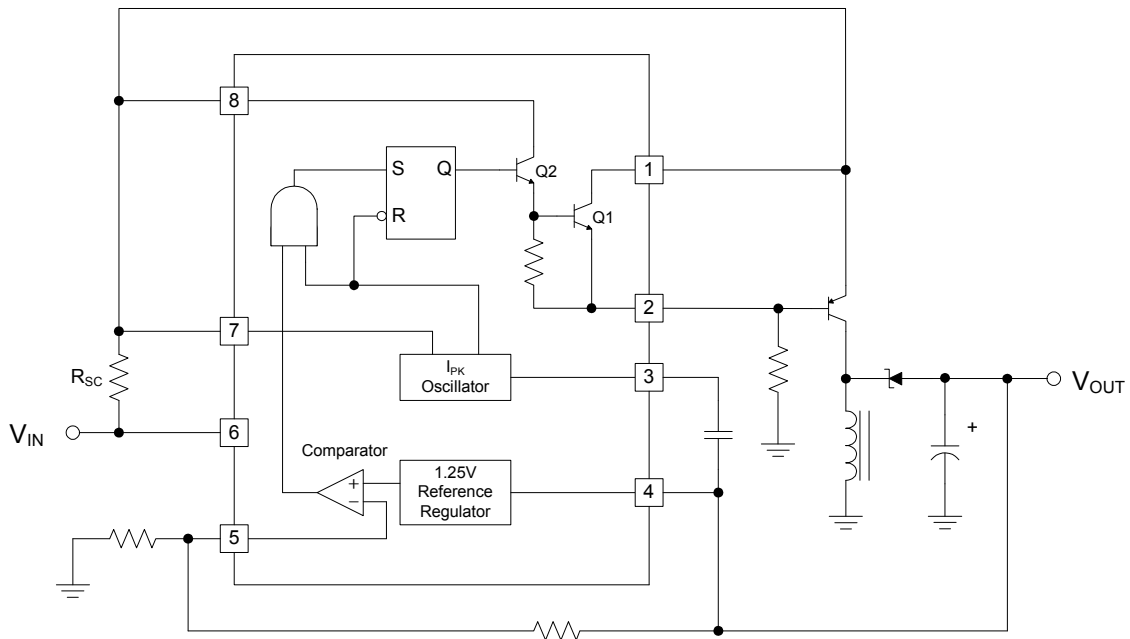

## Step-Down with External PNP Switch

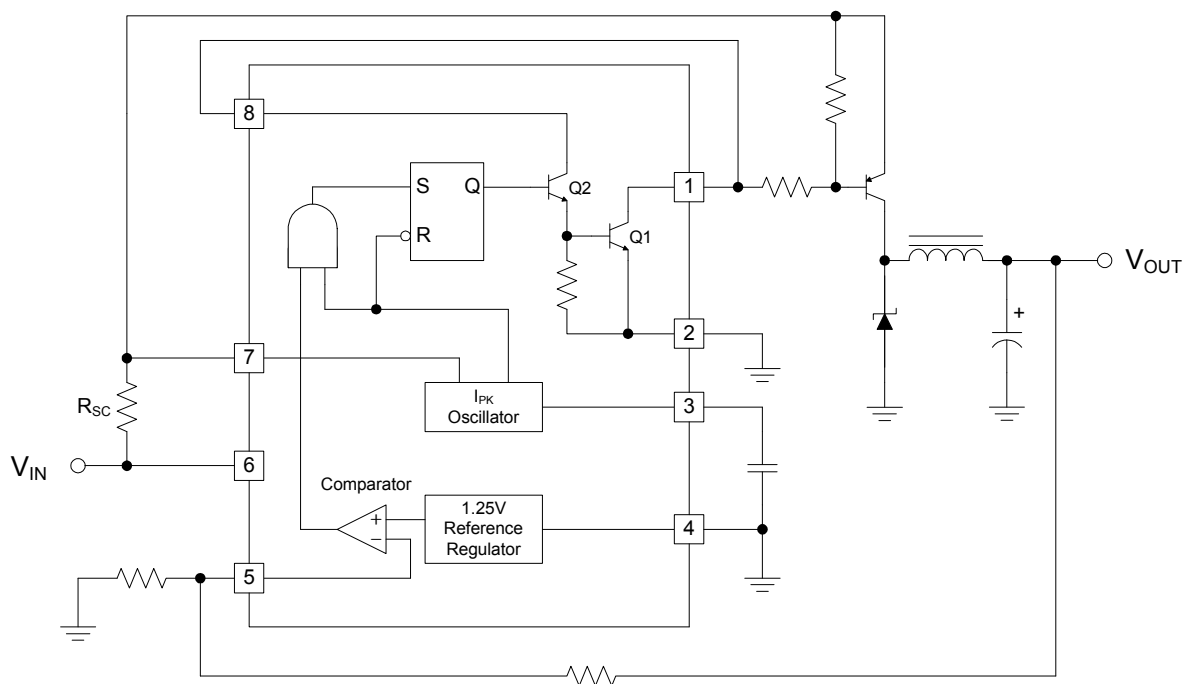

## Voltage Inverting with External NPN Switch

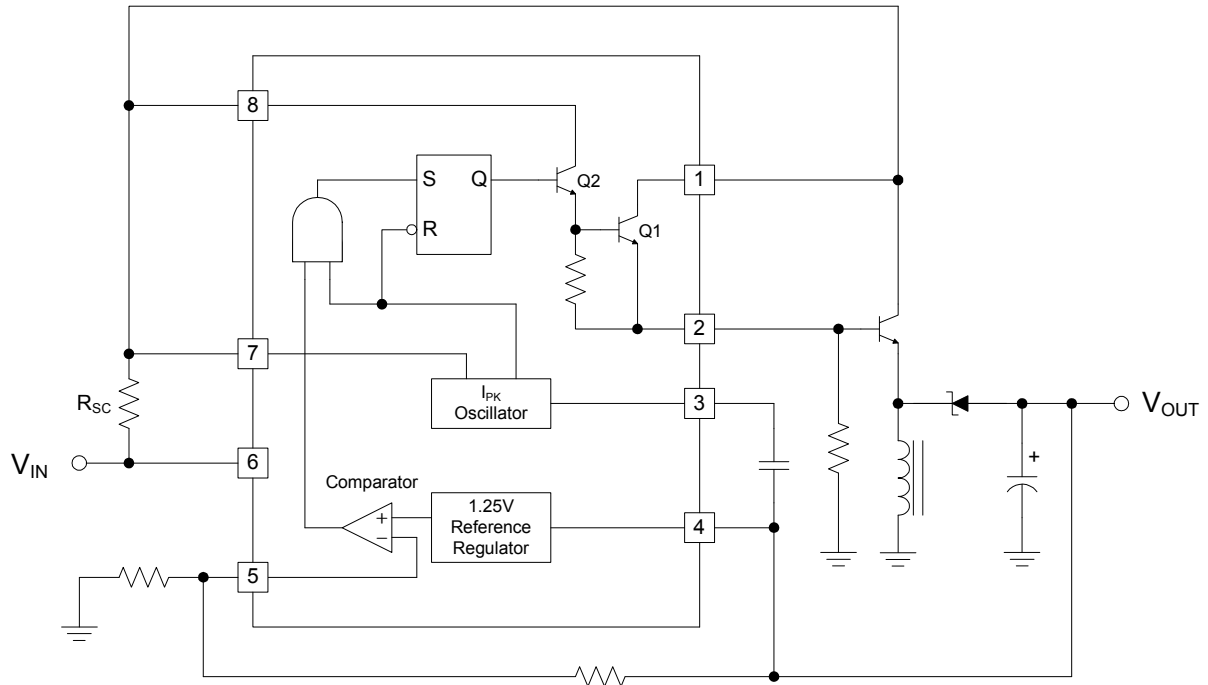

## Voltage Inverting with External PNP Saturated Switch

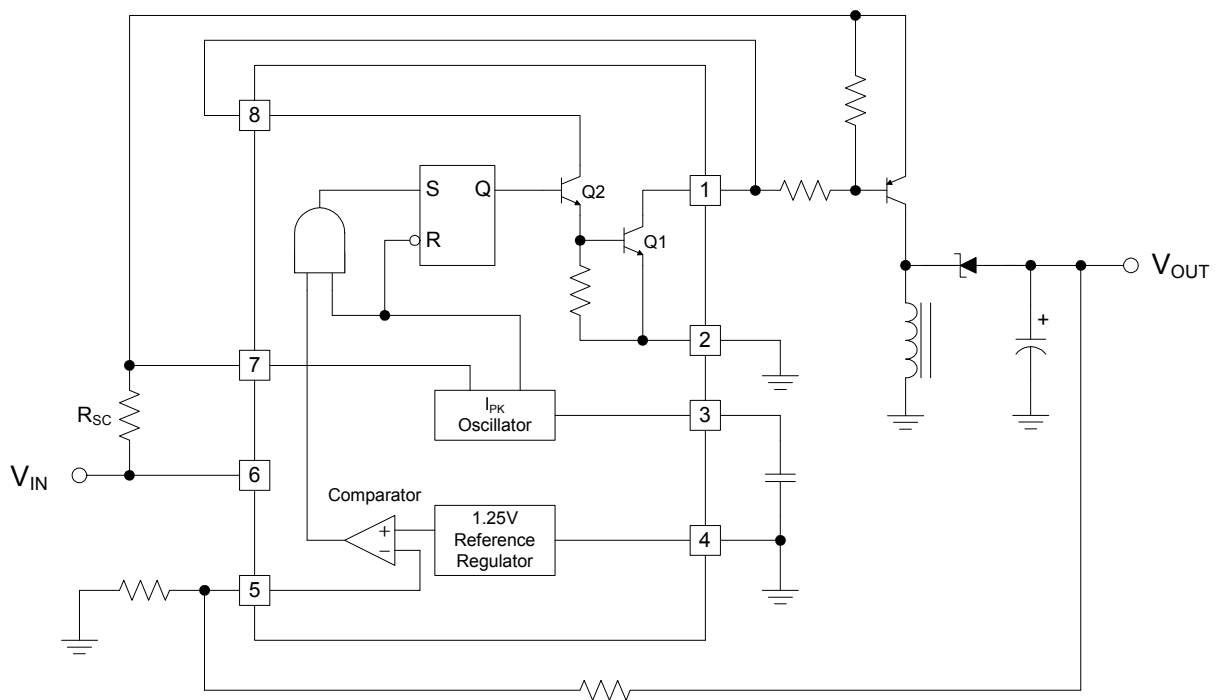

## Dual Output Voltage

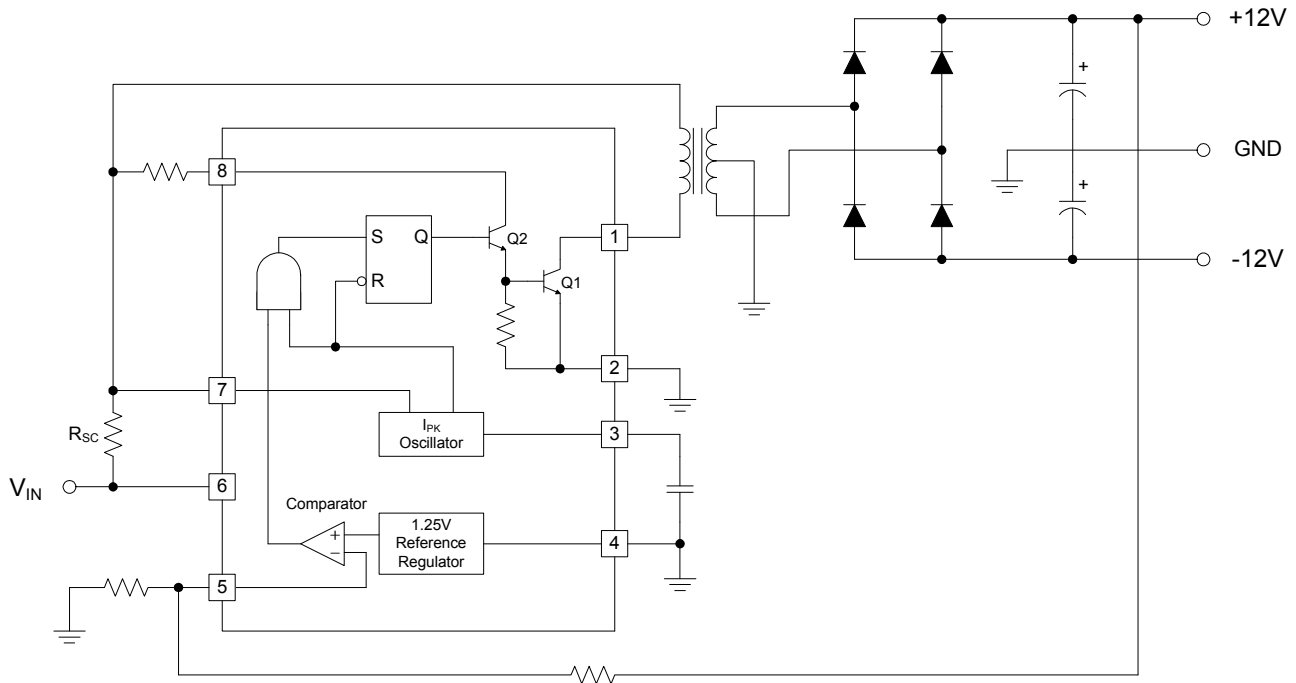

## Higher Output Power, Higher Input Voltage

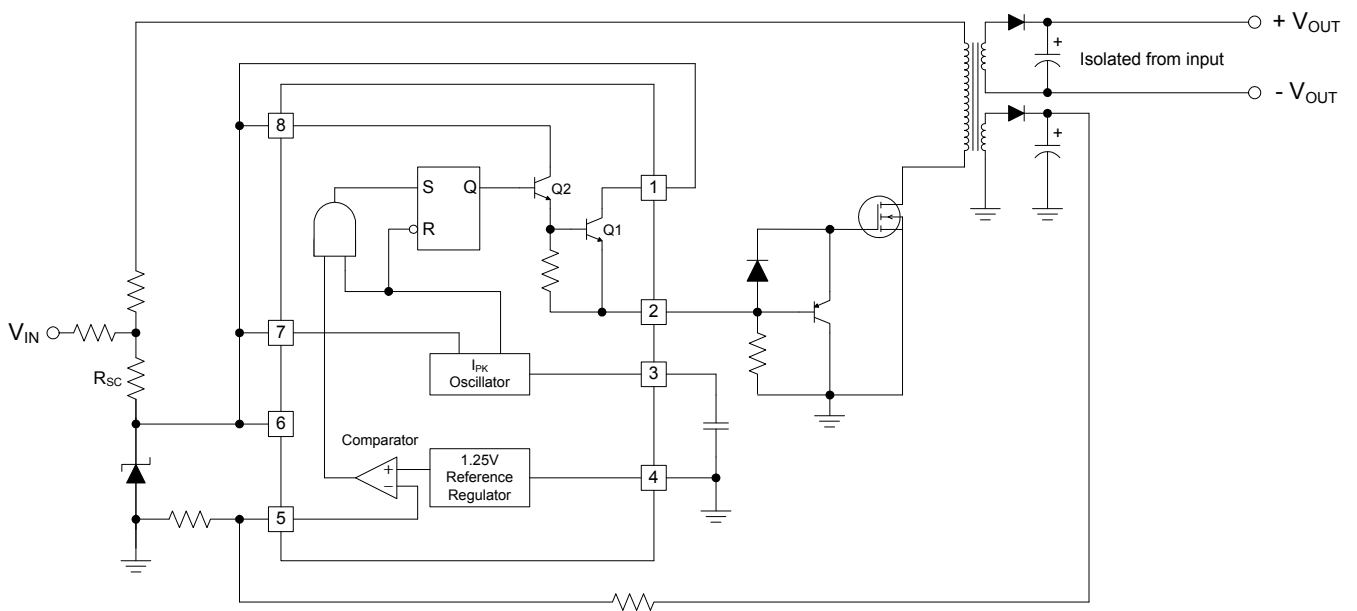

## Design Formula Table

Calculation	Step-UP	Step-Down	Voltage Inverting
$t_{on}/t_{off}$	$\frac{V_{OUT} + V_F - V_{IN(MIN)}}{V_{IN(MIN)} - V_{SAT}}$	$\frac{V_{OUT} + V_F}{V_{IN(MIN)} - V_{SAT}}$	$\frac{ V_{OUT}  + V_F}{V_{IN} - V_{SAT}}$
$(t_{on}/t_{off})_{max}$	$\frac{1}{f_{MIN}}$	$\frac{1}{f_{MIN}}$	$\frac{1}{f_{MIN}}$
$C_T$	$4.0 \times 10^{-5} t_{on}$	$4.0 \times 10^{-5} t_{on}$	$4.0 \times 10^{-5} t_{on}$
$I_{PK(SWITCH)}$	$2 I_{OUT(MAX)} \left( \frac{t_{off}}{t_{on}} + 1 \right)$	$2 I_{OUT(MAX)}$	$2 I_{OUT(MAX)} \left( \frac{t_{off}}{t_{on}} + 1 \right)$
$R_{SC}$	$0.3 / I_{PK(SWITCH)}$	$0.3 / I_{PK(SWITCH)}$	$0.3 / I_{PK(SWITCH)}$
$L_{(MIN)}$	$\left( \frac{V_{IN(MIN)} - V_{SAT}}{I_{PK(SWITCH)}} \right) \times t_{on(max)}$	$\left( \frac{V_{IN(MIN)} - V_{SAT} - V_{OUT}}{I_{PK(SWITCH)}} \right) \times t_{on(max)}$	$\left( \frac{V_{IN(MIN)} - V_{SAT}}{I_{PK(SWITCH)}} \right) \times t_{on(max)}$
$C_O$	$9 \frac{I_{OUT} t_{on}}{V_{RIPPLE(PP)}}$	$\frac{I_{PK(SWITCH)} (t_{on} + t_{off})}{8 V_{RIPPLE(PP)}}$	$9 \frac{I_{OUT} t_{on}}{V_{RIPPLE(PP)}}$

## TERMS AND DEFINITIONS

$V_{SAT}$  - Saturation voltage of the output switch.

$V_F$  - Forward voltage drop of the output rectifier.

### The following power supply characteristics must be chosen:

$V_{IN}$  - Nominal input voltage.

$V_{OUT}$  - Desired output voltage.

$I_{OUT}$  - Desired output current.

$f_{MIN}$  - Minimum desired output switching frequency at the selected values of  $V_{IN}$  and  $I_O$ .

$V_{RIPPLE(P-P)}$  - Desired peak-to-peak output ripple voltage. In practice the calculated capacitor value will need to be increased due to its equivalent series resistance and board layout. The ripple voltage should be kept to a low value since it will directly affect the line and load regulation.