

Body Height 1.4mm, Ultra-compact Sized Tactile Switches

TSW-8 / 8A Series

Features

- ◇ With 3.2x4.1mm dimension and 1.4mm height, these surface-mounting type switches are ideal for high-density mounting.
- ◇ A sharp click feeling of key touch is provided utilizing the tactile feedback characteristic.
- ◇ J-bent terminal and straight terminal are standardized . Permits reflow soldering.
- ◇ With solderable metal covered ground terminal effective for electrostatic discharge.
- ◇ Switches are packaged in 12mm wide embossed taping.

Applications

- ◇ Digital still camera and digital video camera
- ◇ Audio products, VTR and car navigation system
- ◇ Cellular phone , PDA

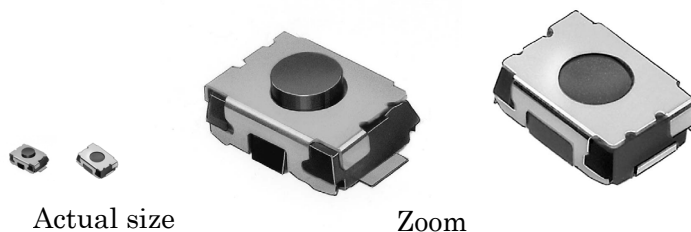

Products Line

- ◇ With stem type (TSW-8)

No	Products No	Operating force	Travel	Terminal style	Variety	Qty/reel(pcs.)
1	TSW-8-07-T40	0.7N	0.15mm	J-bent	Without guide bosses	4,000 (Minimum packing unit)
1	TSW-8-07B-T40				With guide bosses	
2	TSW-8-1-07-T40			Straight	Without guide bosses	
2	TSW-8-1-07B-T40				With guide bosses	
1	TSW-8-10-T40	1.0N		J-bent	Without guide bosses	
1	TSW-8-10B-T40				With guide bosses	
2	TSW-8-1-10-T40			Straight	Without guide bosses	
2	TSW-8-1-10B-T40				With guide bosses	
1	TSW-8-16-T40	1.6N	J-bent	Without guide bosses		
1	TSW-8-16B-T40			With guide bosses		
2	TSW-8-1-16-T40		Straight	Without guide bosses		
2	TSW-8-1-16B-T40			With guide bosses		

◇ With flat stem type (TSW-8A)

No	Products No.	Operating force	Travel	Terminal style	Variety	Qty/reel(pcs.)
3	TSW-8A-07-T40	0.7N	0.15mm	J-bent	Without guide bosses	4,000 (Minimum packing unit)
3	TSW-8A-07B-T40				With guide bosses	
4	TSW-8A-1-07-T40			Straight	Without guide bosses	
4	TSW-8A-1-07B-T40				With guide bosses	
3	TSW-8A-10-T40	1.0N		J-bent	Without guide bosses	
3	TSW-8A-10B-T40				With guide bosses	
4	TSW-8A-1-10-T40			Straight	Without guide bosses	
4	TSW-8A-1-10B-T40				With guide bosses	
3	TSW-8A-16-T40	1.6N		J-bent	Without guide bosses	
3	TSW-8A-16B-T40				With guide bosses	
4	TSW-8A-1-16-T40			Straight	Without guide bosses	
4	TSW-8A-1-16B-T40				With guide bosses	

□ Typical Specifications

Item	Specifications
Ratings (max.) (Resistive load)	50mA 12V DC
Contact resistance	100 milliohm max. (Initial)
Insulation resistance	100 megohm min. 100V DC
Withstanding voltage	250V AC for 1min.
Operating life	100,000 cycles
Operating temperature range	-20 to +70 degree Celsius
Storage temperature range	-40 to +80 degree Celsius (except carrier tape)

Dimensions

Unit : mm

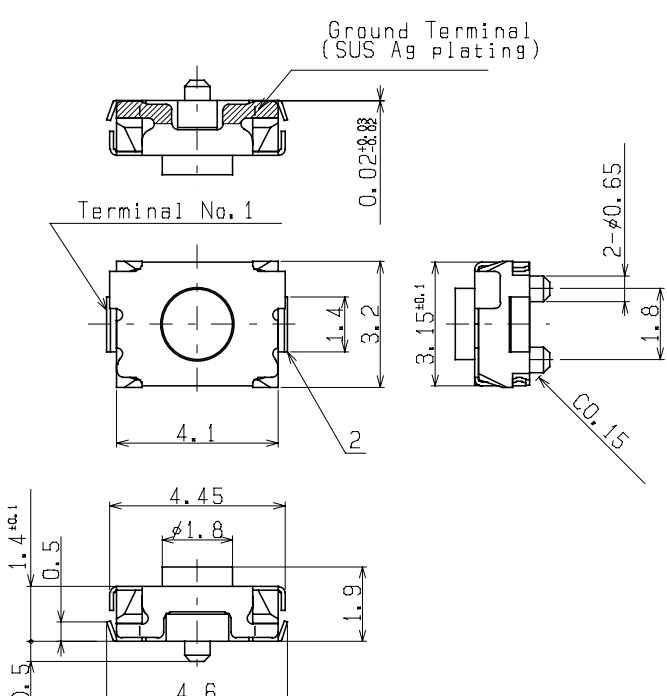
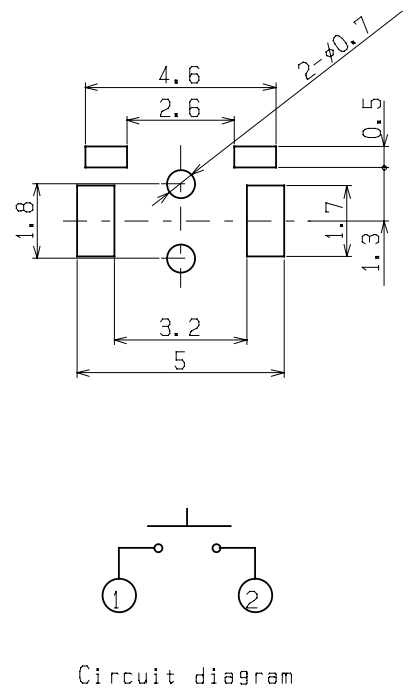
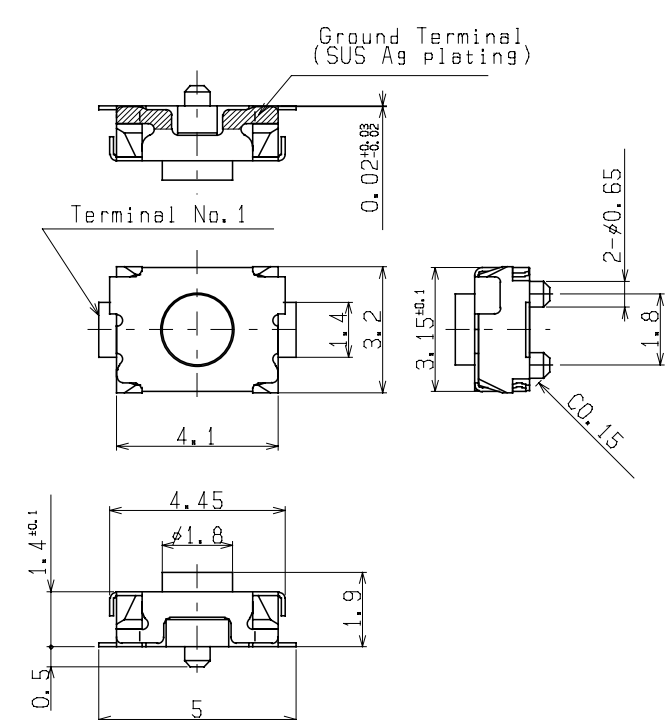
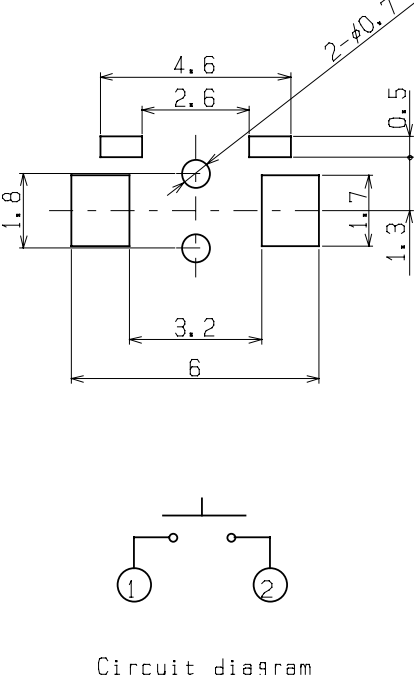
No	Style	P.C.B reference Land Dimensions Circuit Diagram (TOP VIEW)
1	<p>J-bent terminal TSW-8-07-T40, TSW-8-07B-T40, TSW-8-10-T40, TSW-8-10B-T40, TSW-8-16-T40, TSW-8-16B-T40</p> 	 <p>Circuit diagram</p>
<p>Above is the drawing of TSW-8 with guiding bosses.</p>		
2	<p>Straight terminal TSW-8-1-07-T40, TSW-8-1-07B-T40, TSW-8-1-10-T40, TSW-8-1-10B-T40, TSW-8-1-16-T40, TSW-8-1-16B-T40</p> 	 <p>Circuit diagram</p>
<p>Above is the drawing of TSW-8 with guiding bosses.</p>		

□ Notes

1. The appearance and specifications of the product may be modified to improve its performance without prior notice.
2. This catalog shows only outline specifications. When using the product, please obtain formal specifications.
3. Please see appendix [Cautions in Using Switches].
4. 4,000 pcs/one reel is the minimum packing unit. It is requested that the quantity of the order shall be an integer multiple of the minimum packing units.
5. Please set the reflow soldering condition confirming under the actual conditions of mass-production.
6. Characteristics of switch may change due to the warping of the circuit writing board. Consideration should be given to the pattern design and layout.
7. This push switch is not washable.
8. This push switch permits reflow soldering and the switch has the possibility to be mounted on the edge of the PC board. But auto-dip shall not be done after the mounting of the switch because of the big possibility of the penetration of the soldering flux into the contacts sliding portion.
9. Larger stress than specified and/ or shock shall not be applied during switch operation. Pressure to the push button shall be applied to the whole surface equally and avoid the pressure to the specific one portion.
10. In manual soldering, consider that the abnormal pressure of the soldering iron shall not be applied to the tip of the terminal as well do not apply any pressure for more than 1 minute after soldering.
11. Care shall be taken so that the flux shall not penetrate into the terminal portion.
12. The operating characteristic may change if force is exerted to the top of the cover.