

# Detector Switch ( Lever Type )

## MLS-29AU Series

### Feature

- ◇ This switch is a light movement with small type.
- ◇ Superb reliability by adopting cross-bar contact.
- ◇ Wide lever-variation.

### Applications

- ◇ Mechanism for general audio and car audio products.
- ◇ FAX, Label printer
- ◇ For various kind of low current switching use.



MLS-29AU



MLS-29AUS3



MLS-16



MLS-31AUS



MLS-32AU



MLS-36AU

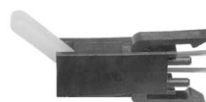

MLS-38AUS



MLS-42AU



MLS-47

### Products Line



No	Products No	Poles	Positions	Fixing method	Operating force
1	MLS-16	1	1	Screw	0.69N max
2	MLS-29AU	1	1	Screw	0.69N max
3	MLS-29AUS3	1	1	Screw	0.69N max
4	MLS-31AUS	1	1	Snap in	0.69N max
5	MLS-32AU	1	1	Screw	0.69N max
6	MLS-36AU	1	1	Screw	0.69N max
7	MLS-38AUS	1	1	Snap in	0.69N max
8	MLS-42AU	1	1	Snap in	0.29N max
9	MLS-47	1	1	Screw	0.69N max

### Typical Specifications

Items	Specifications
Ratings (max) (Resistive load)	20mA 16V DC (Resistive load)
Contact resistance	50 milliohm max
Insulation resistance	50 megohm min. 250V DC
Withstanding voltage	250V AC for 1min
Operating life	20,000 cycles

Dimensions

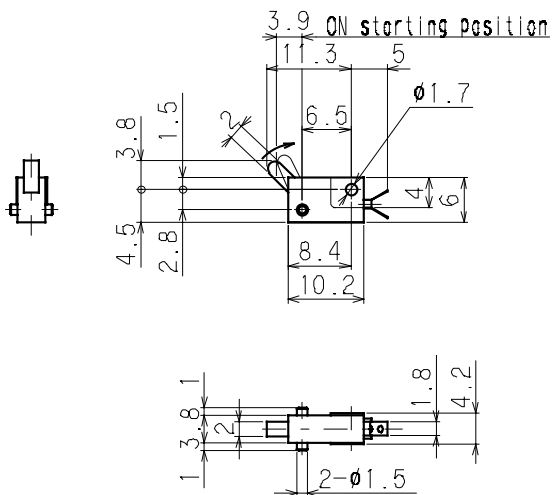
Unit : mm

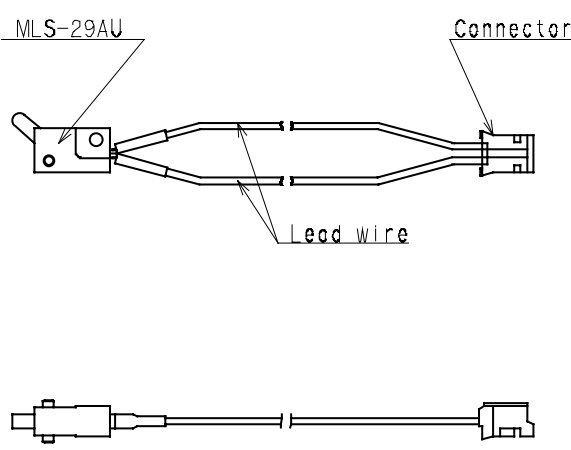
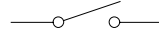
No	Style	P.C.B reference Land Dimensions Circuit Diagram (TOP VIEW)
1	<p>MLS-29AU</p> 	
2	<p>MLS-29AUS3</p> 	





Dimensions

Unit : mm

No	Style	P.C.B(TOP VIEW) Circuit Diagram
3	<p>MLS-16</p>	
4	<p>MLS-31AUS</p>	

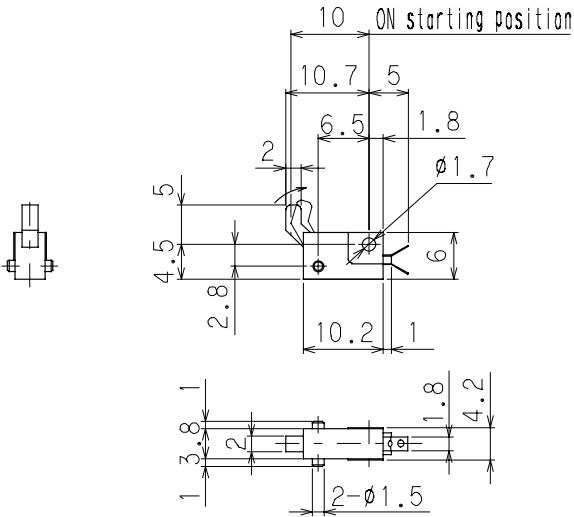
Dimensions

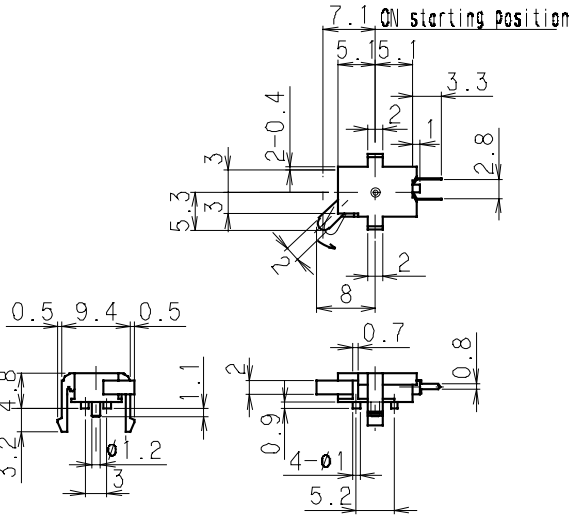

Unit : mm

No	Style	P.C.B reference Land Dimensions Circuit Diagram (TOP VIEW)
5	<p>MLS-32AU</p> 	
6	<p>MLS-36AU</p> 	

Dimensions

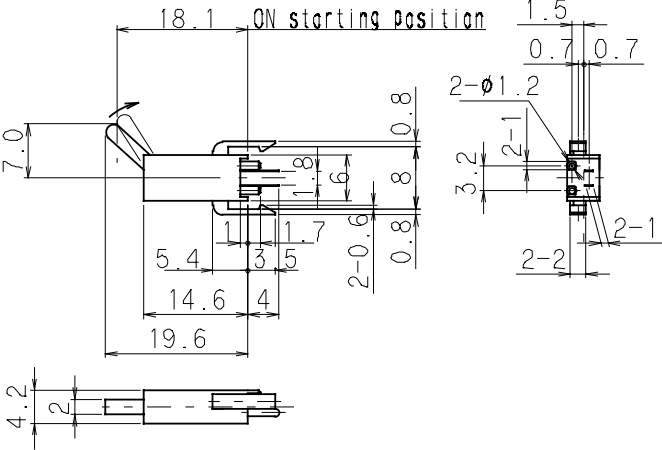
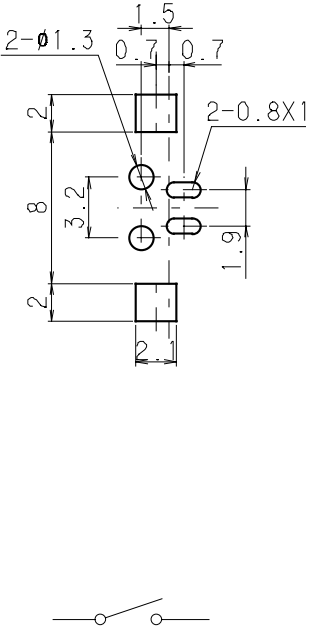
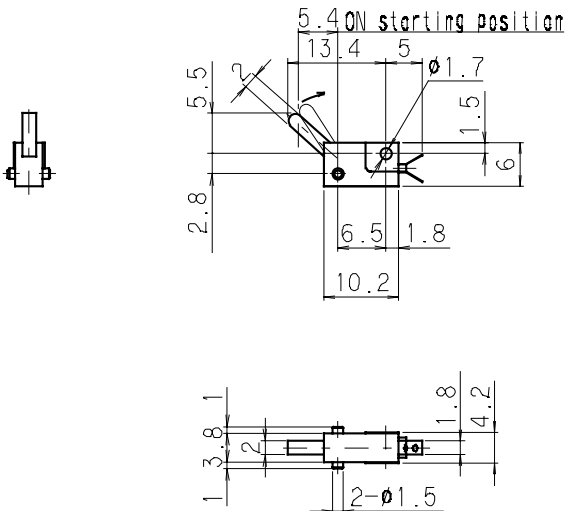
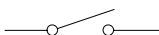
Unit : mm

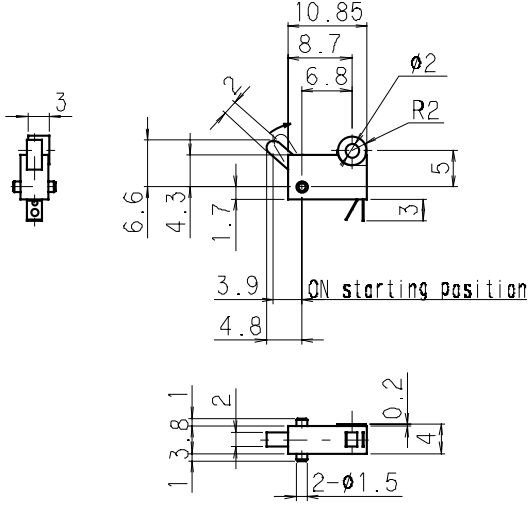
No	Style	P.C.B reference Land Dimensions Circuit diagram (TOP VIEW)
7	<p>MLS-38AUS</p> 	
8	<p>MLS-42AU</p> 	

No	Style	P.C.B reference Land Dimensions Circuit diagram (TOP VIEW)
9	<p>MLS-42AU</p> 	

Notes

1. The appearance and specifications of the product may be modified without prior notice to improve its performance.
2. This catalog shows only outline specifications. When using the product, please obtain formal specifications supply.
3. Please see appendix [Cautions in Using Switches ].
4. For high safety applications, please confirm with protection and redundant circuit.
5. This detector switch is not a washable type.
6. In manual soldering, consideration should be given to apply the soldering iron to the tip of the terminal so that unusual pressure is not applied to the terminal.
7. Please do not apply pressure for 1 minute after soldering.
8. Since soldering quality may deteriorate due to sulfuration and oxidation of terminals, please use as soon as possible within maximum 6 months after delivery and use within a after opening the package condition and the one within 1 week after you unpack it again.
9. Please confirm the performance on actual operation by simulation with actual environment environments for high reliability.