

CBT3384

10-bit bus switch with 5-bit output enables

Rev. 06 — 2 November 2009

Product data sheet

1. General description

The CBT3384 provides ten bits of high-speed TTL-compatible bus switching. The low ON resistance of the switch allows connections to be made with minimal propagation delay.

The CBT3384 device is organized as two 5-bit bus switches with two separate output enable ($1\overline{OE}$, $2\overline{OE}$) inputs. When $n\overline{OE}$ is LOW, the switch is on and port A is connected to the B port. When $n\overline{OE}$ is HIGH, each switch is disabled.

The CBT3384 is characterized for operation from $-40\text{ }^{\circ}\text{C}$ to $+85\text{ }^{\circ}\text{C}$.

2. Features

- 5 Ω switch connection between two ports
- TTL-compatible control input levels
- Multiple package options
- See CBTD3384 for CBT3384 with level shifting diodes
- Latch-up protection exceeds 100 mA per JESD78
- ESD protection:
 - ◆ HBM JESD22-A114E exceeds 2000 V
 - ◆ CDM JESD22-C101C exceeds 1000 V

3. Ordering information

Table 1. Ordering information

Type number	Package			
	Temperature range	Name	Description	Version
CBT3384D	$-40\text{ }^{\circ}\text{C}$ to $+85\text{ }^{\circ}\text{C}$	SO24	plastic small outline package; 24 leads; body width 7.5 mm	SOT137-1
CBT3384DB	$-40\text{ }^{\circ}\text{C}$ to $+85\text{ }^{\circ}\text{C}$	SSOP24	plastic shrink small outline package; 24 leads; body width 5.3 mm	SOT340-1
CBT3384DK	$-40\text{ }^{\circ}\text{C}$ to $+85\text{ }^{\circ}\text{C}$	SSOP24 ^[1]	plastic shrink small outline package; 24 leads; body width 3.9 mm; lead pitch 0.635 mm	SOT556-1
CBT3384PW	$-40\text{ }^{\circ}\text{C}$ to $+85\text{ }^{\circ}\text{C}$	TSSOP24	plastic thin shrink small outline package; 24 leads; body width 4.4 mm	SOT355-1

[1] Also known as QSOP24 package

4. Functional diagram

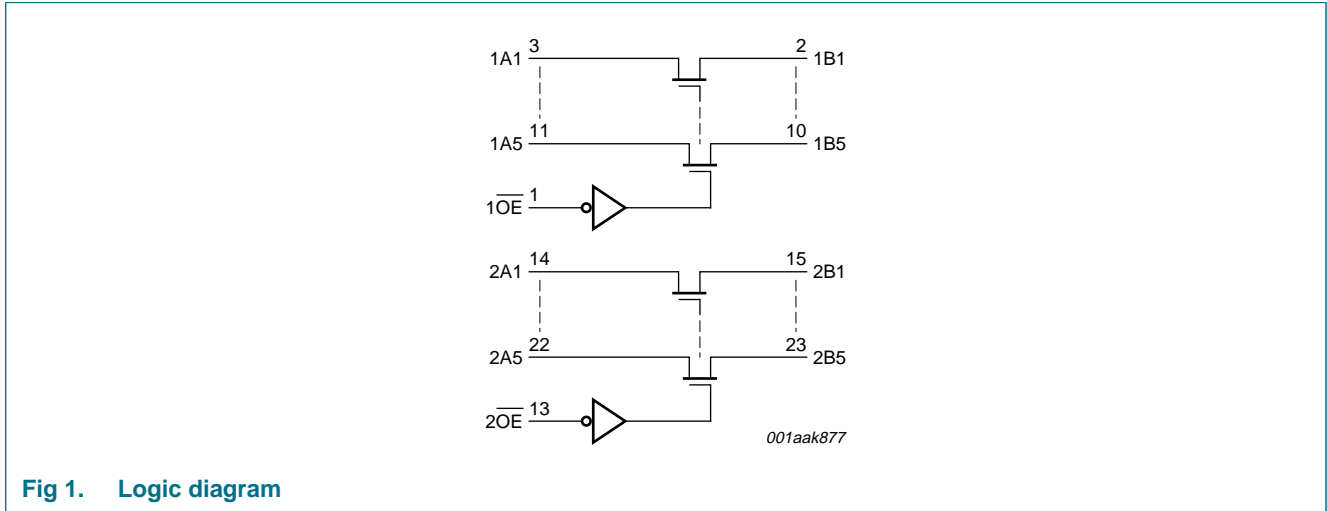

Fig 1. Logic diagram

5. Pinning information

5.1 Pinning

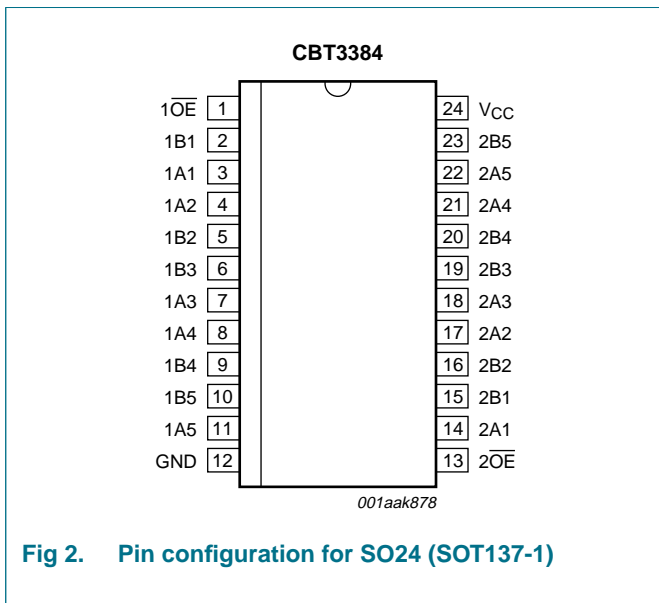

Fig 2. Pin configuration for SO24 (SOT137-1)

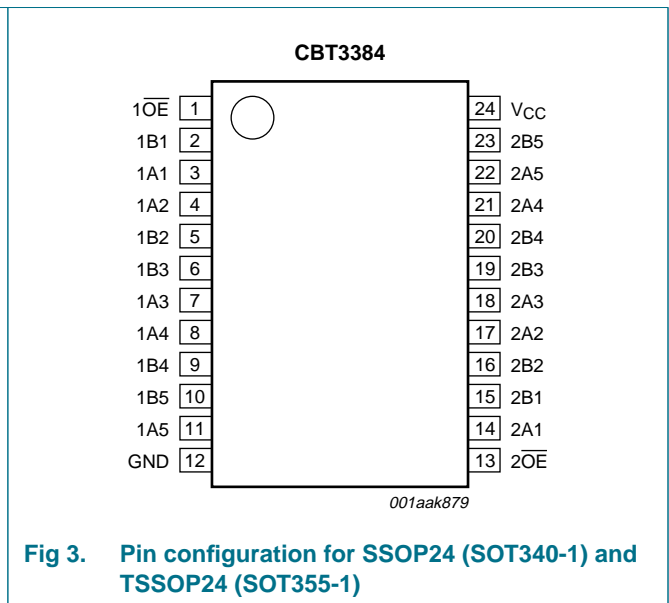

Fig 3. Pin configuration for SSOP24 (SOT340-1) and TSSOP24 (SOT355-1)

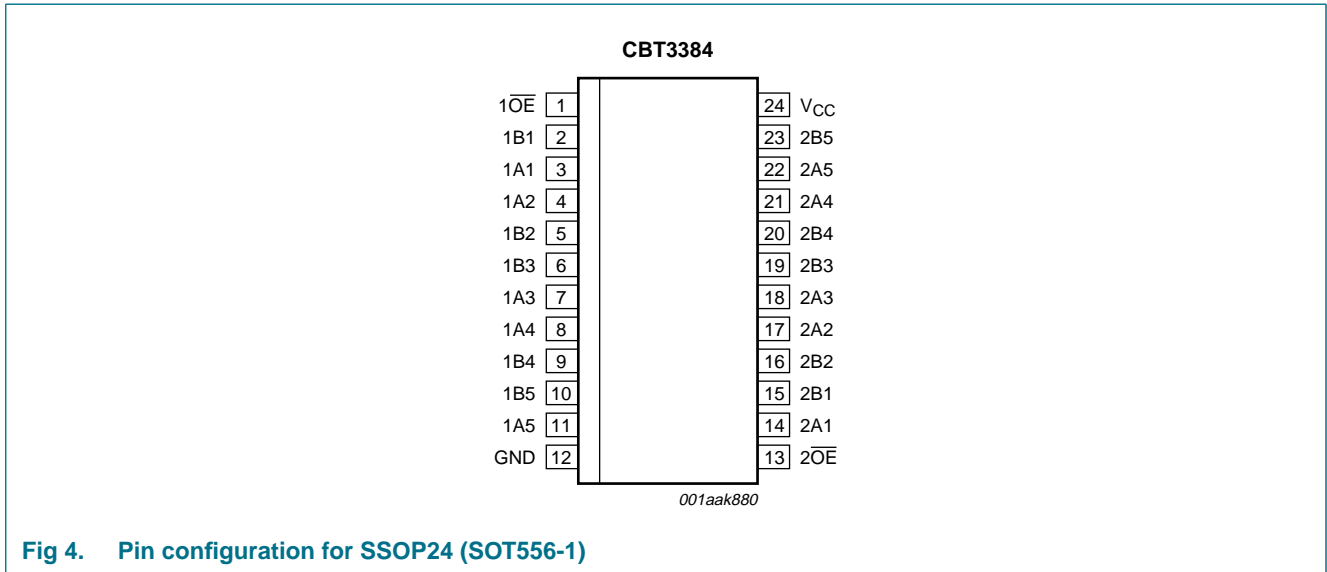

Fig 4. Pin configuration for SSOP24 (SOT556-1)

5.2 Pin description

Table 2. Pin description

Symbol	Pin	Description
1OE, 2OE	1, 13	output enable input (active LOW)
1A1 to 1A5	3, 4, 7, 8, 11	data input/output (A port)
2A1 to 2A5	14, 17, 18, 21, 22	data input/output (A port)
1B1 to 1B5	2, 5, 6, 9, 10	data input/output (B port)
2B1 to 2B5	15, 16, 19, 20, 23	data input/output (B port)
GND	12	ground (0 V)
VCC	24	positive supply voltage

6. Functional description

Table 3. Function selection^[1]

Input		Input/output	
1OE	2OE	1An, 1Bn	2An, 2Bn
L	L	1An = 1Bn	2An = 2Bn
L	H	1An = 1Bn	Z
H	L	Z	2An = 2Bn
H	H	Z	Z

[1] H = HIGH voltage level; L = LOW voltage level; Z = high-impedance OFF-state.

7. Limiting values

Table 4. Limiting values

In accordance with the Absolute Maximum Rating System (IEC 60134).^[1]

$T_{amb} = -40\text{ °C to }+85\text{ °C}$, unless otherwise specified.

Symbol	Parameter	Conditions	Min	Max	Unit
V_{CC}	supply voltage		-0.5	+7.0	V
V_I	input voltage		^[2] -0.5	+7.0	V
I_O	output current	$V_O < 0\text{ V}$	-	±128	mA
I_{IK}	input clamping current	$V_{I/O} = 0\text{ V}$	-50	-	mA
T_{stg}	storage temperature		-65	+150	°C

[1] Stresses beyond those listed may cause permanent damage to the device. These are stress ratings only and functional operation of the device at these or any other conditions beyond those indicated under [Section 8](#). is not implied. Exposure to absolute-maximum-rated conditions for extended periods may affect device reliability.

[2] The input and output negative-voltage ratings may be exceeded if the input and output clamp-current ratings are observed.

8. Recommended operating conditions

Table 5. Operating conditions

All unused control inputs of the device must be held at V_{CC} or GND to ensure proper device operation.

Symbol	Parameter	Conditions	Min	Typ	Max	Unit
V_{CC}	supply voltage		4.5	-	5.5	V
V_{IH}	HIGH-state input voltage		2.0	-	-	V
V_{IL}	LOW-state input voltage		-	-	0.8	V
T_{amb}	ambient temperature	operating in free air	-40	-	+85	°C

9. Static characteristics

Table 6. Static characteristics

Voltages are referenced to GND (ground = 0 V).

Symbol	Parameter	Conditions	$T_{amb} = -40\text{ °C to }+85\text{ °C}$			Unit
			Min	Typ ^[1]	Max	
V_{IK}	input clamping voltage	$V_{CC} = 4.5\text{ V}; I_I = -18\text{ mA}$	-	-	-1.2	V
I_I	input leakage current	$V_{CC} = 5.5\text{ V}; V_I = \text{GND or } 5.5\text{ V}$	-	-	±1	µA
I_{CC}	supply current	$V_{CC} = 5.5\text{ V}; I_O = 0\text{ mA}; V_I = V_{CC}\text{ or GND}$	-	-	3	µA
ΔI_{CC}	additional supply current	per input pin; $V_{CC} = 5.5\text{ V}$; one input at 3.4 V, other inputs at V_{CC} or GND ^[2]	-	-	2.5	mA
V_{pass}	pass voltage	output HIGH; $V_I = V_{CC} = 5.0\text{ V}; I_O = -100\text{ µA}$	3.6	3.9	4.2	V
C_I	input capacitance	control pins; $V_I = 3\text{ V or } 0\text{ V}$	-	4.0	-	pF
$C_{io(off)}$	off-state input/output capacitance	port off; $V_I = 3\text{ V or } 0\text{ V}; n\overline{OE} = V_{CC}$	-	10.0	-	pF

Table 6. Static characteristics ...continued
 Voltages are referenced to GND (ground = 0 V).

Symbol	Parameter	Conditions	T _{amb} = -40 °C to +85 °C			Unit
			Min	Typ ^[1]	Max	
R _{ON}	ON resistance	V _{CC} = 4.5 V; V _I = 0 V; I _I = 64 mA [3]	-	5	7	Ω
		V _{CC} = 4.5 V; V _I = 0 V; I _I = 30 mA [3]	-	5	7	Ω
		V _{CC} = 4.5 V; V _I = 2.4 V; I _I = -15 mA [3]	-	10	15	Ω

- [1] All typical values are at V_{CC} = 5 V, T_{amb} = 25 °C.
- [2] This is the increase in supply current for each input that is at the specified TTL voltage level rather than V_{CC} or GND.
- [3] Measured by the voltage drop between the nAn and the nBn terminals at the indicated current through the switch. ON resistance is determined by the lowest voltage of the two (nAn or nBn) terminals.

10. Dynamic characteristics

Table 7. Dynamic characteristics
 Voltages are referenced to GND (ground = 0 V). For test circuit see [Figure 7](#).

Symbol	Parameter	Conditions	T _{amb} = 25 °C			T _{amb} = -40 °C to +85 °C		Unit
			Min	Typ	Max	Min	Max	
t _{pd}	propagation delay	nAn, nBn to nBn, nAn; [1][2] see Figure 5						
		V _{CC} = 5.0 V ± 0.5 V	-	-	0.25	-	0.25	ns
t _{PZH}	OFF-state to HIGH propagation delay	n $\overline{O}E$ to nAn or nBn; see Figure 6						
		V _{CC} = 5.0 V ± 0.5 V	1.2	2.3	5.7	1.2	5.6	ns
t _{PZL}	OFF-state to LOW propagation delay	n $\overline{O}E$ to nAn or nBn; see Figure 6						
		V _{CC} = 5.0 V ± 0.5 V	1.2	2.3	5.7	1.2	6.0	ns
t _{PHZ}	HIGH to OFF-state propagation delay	n $\overline{O}E$ to nAn or nBn; see Figure 6						
		V _{CC} = 5.0 V ± 0.5 V	1.7	3.6	5.2	1.7	5.5	ns
t _{PLZ}	LOW to OFF-state propagation delay	n $\overline{O}E$ to nAn or nBn; see Figure 6						
		V _{CC} = 5.0 V ± 0.5 V	1.7	2.7	5.2	1.7	6.6	ns

- [1] The propagation delay is the calculated RC time constant of the typical ON resistance of the switch and the specified load capacitance, when driven by an ideal voltage source (zero output impedance).
- [2] t_{pd} is the same as t_{PLH} and t_{PHL}.

11. Waveforms

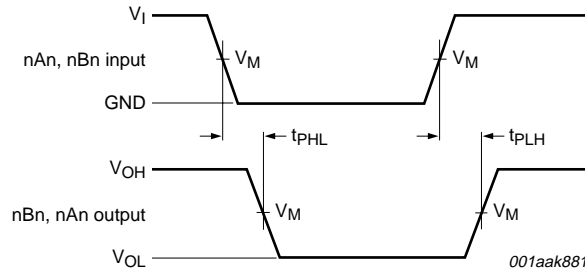

Measurement points are given in [Table 8](#).
 Logic levels: V_{OL} and V_{OH} are typical output voltage levels that occur with the output load.

Fig 5. The data input (nAn, nBn) to output (nBn, nAn) propagation delay times

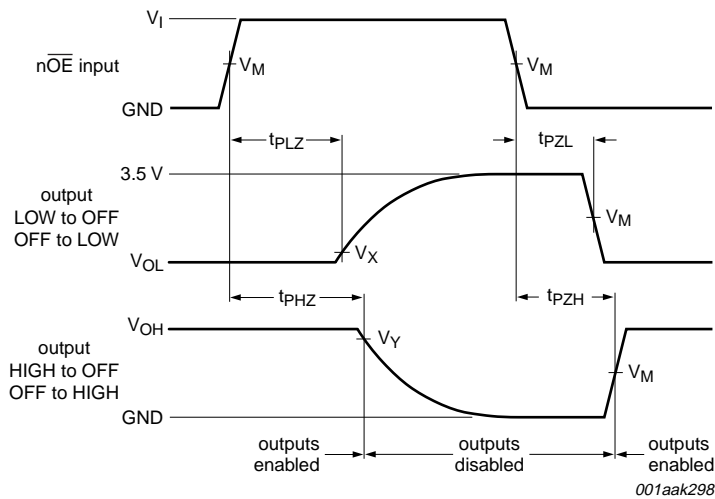

Measurement points are given in [Table 8](#).
 Logic levels: V_{OL} and V_{OH} are typical output voltage levels that occur with the output load.

Fig 6. Enable and disable times

Table 8. Measurement points

Supply voltage	Input		Output		
V_{CC}	V_I	V_M	V_M	V_X	V_Y
$V_{CC} = 5.0\text{ V} \pm 0.5\text{ V}$	GND to 3.0 V	1.5 V	1.5 V	$V_{OL} + 0.3\text{ V}$	$V_{OH} - 0.3\text{ V}$

12. Test information

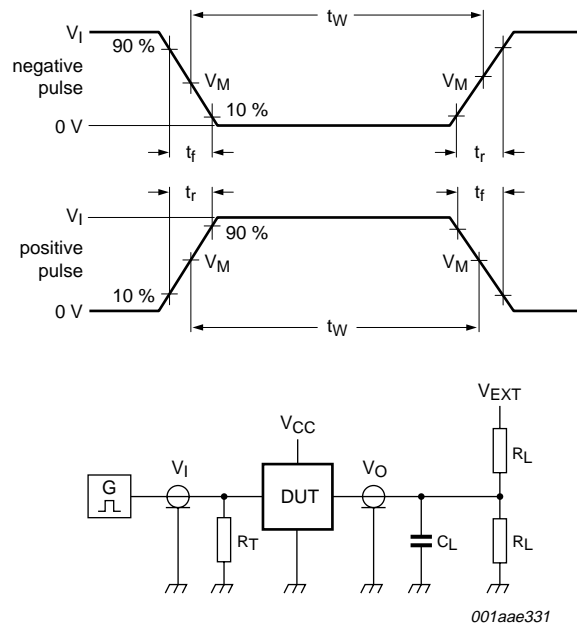

Test data is given in [Table 9](#).

All input pulses are supplied by generators having the following characteristics: PRR ≤ 10 MHz; Z_o = 50 Ω.

The outputs are measured one at a time with one transition per measurement.

Definitions for test circuit:

R_L = Load resistance.

C_L = Load capacitance including jig and probe capacitance.

R_T = Termination resistance should be equal to output impedance Z_o of the pulse generator.

V_{EXT} = External voltage for measuring switching times.

Fig 7. Test circuit for measuring switching times

Table 9. Test data

Supply voltage	Input		Load		V _{EXT}		
	V _I	t _r , t _f	C _L	R _L	t _{PLH} , t _{PHL}	t _{PLZ} , t _{PZL}	t _{PHZ} , t _{PZH}
V _{CC} = 5.0 V ± 0.5 V	GND to 3.0 V	≤ 2.5 ns	50 pF	500 Ω	open	7.0 V	open

13. Package outline

SO24: plastic small outline package; 24 leads; body width 7.5 mm

SOT137-1

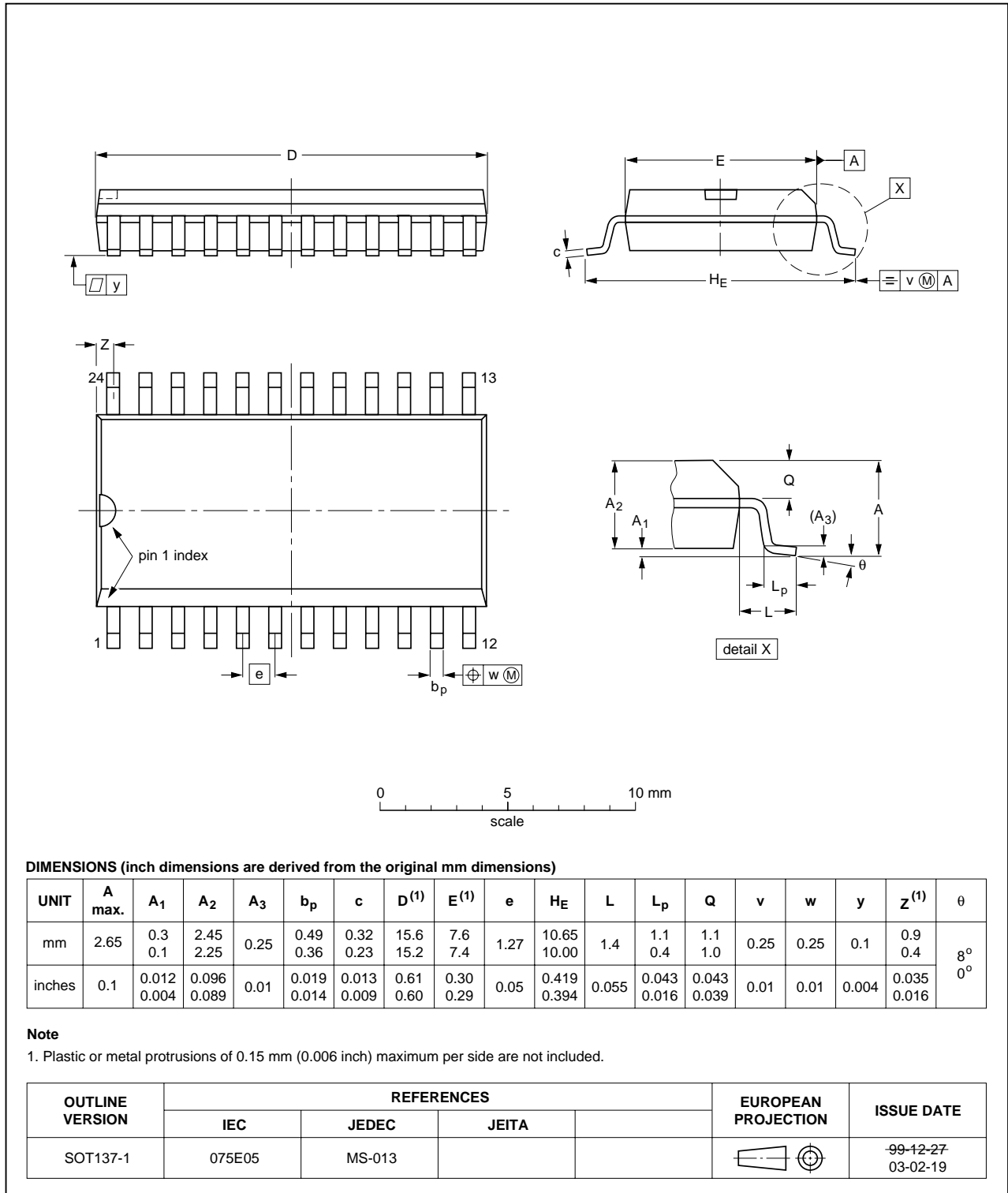

Fig 8. Package outline SOT137-1 (SO24)

SSOP24: plastic shrink small outline package; 24 leads; body width 5.3 mm

SOT340-1

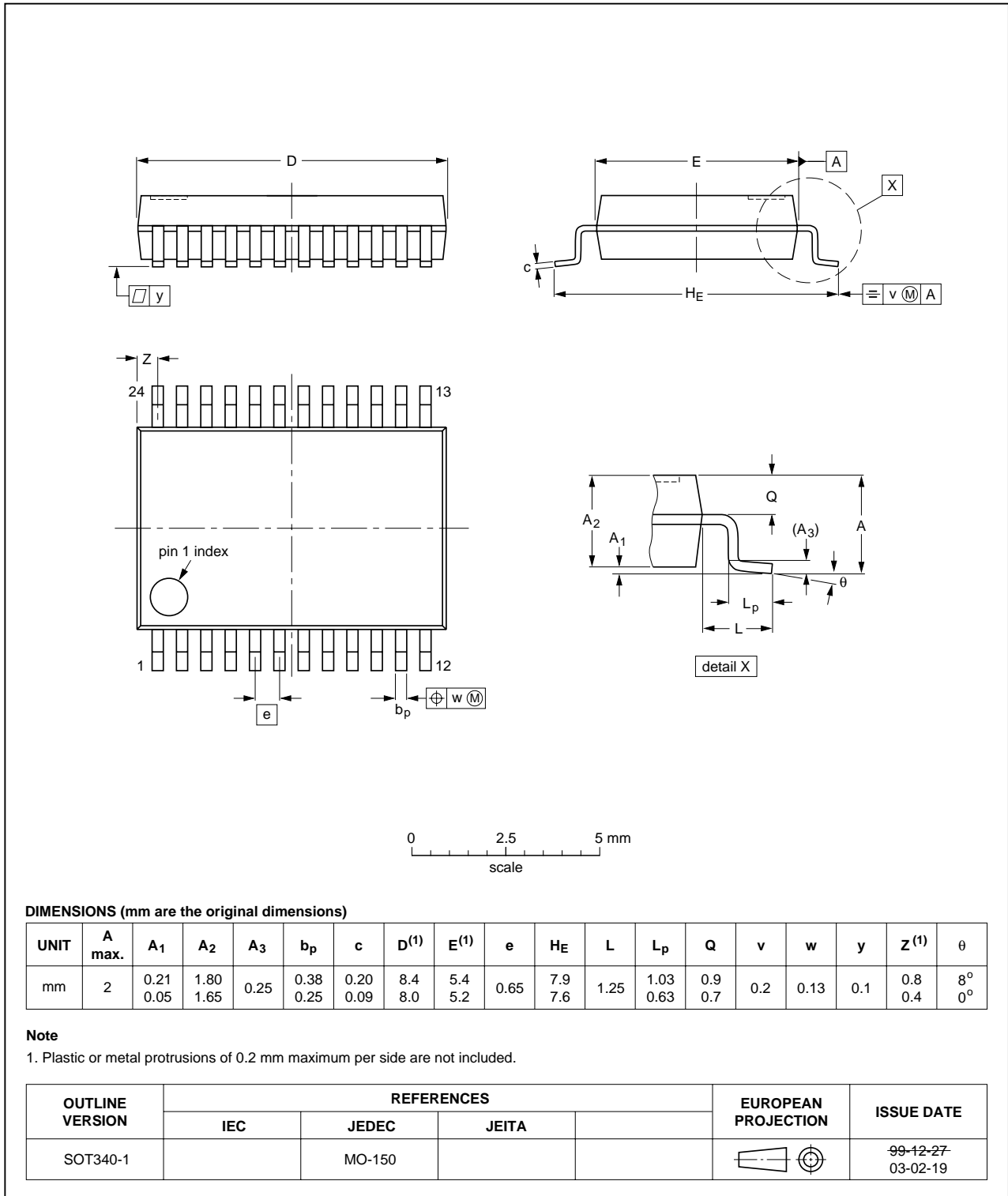

Fig 9. Package outline SOT340-1 (SSOP24)

SSOP24: plastic shrink small outline package; 24 leads; body width 3.9 mm; lead pitch 0.635 mm SOT556-1

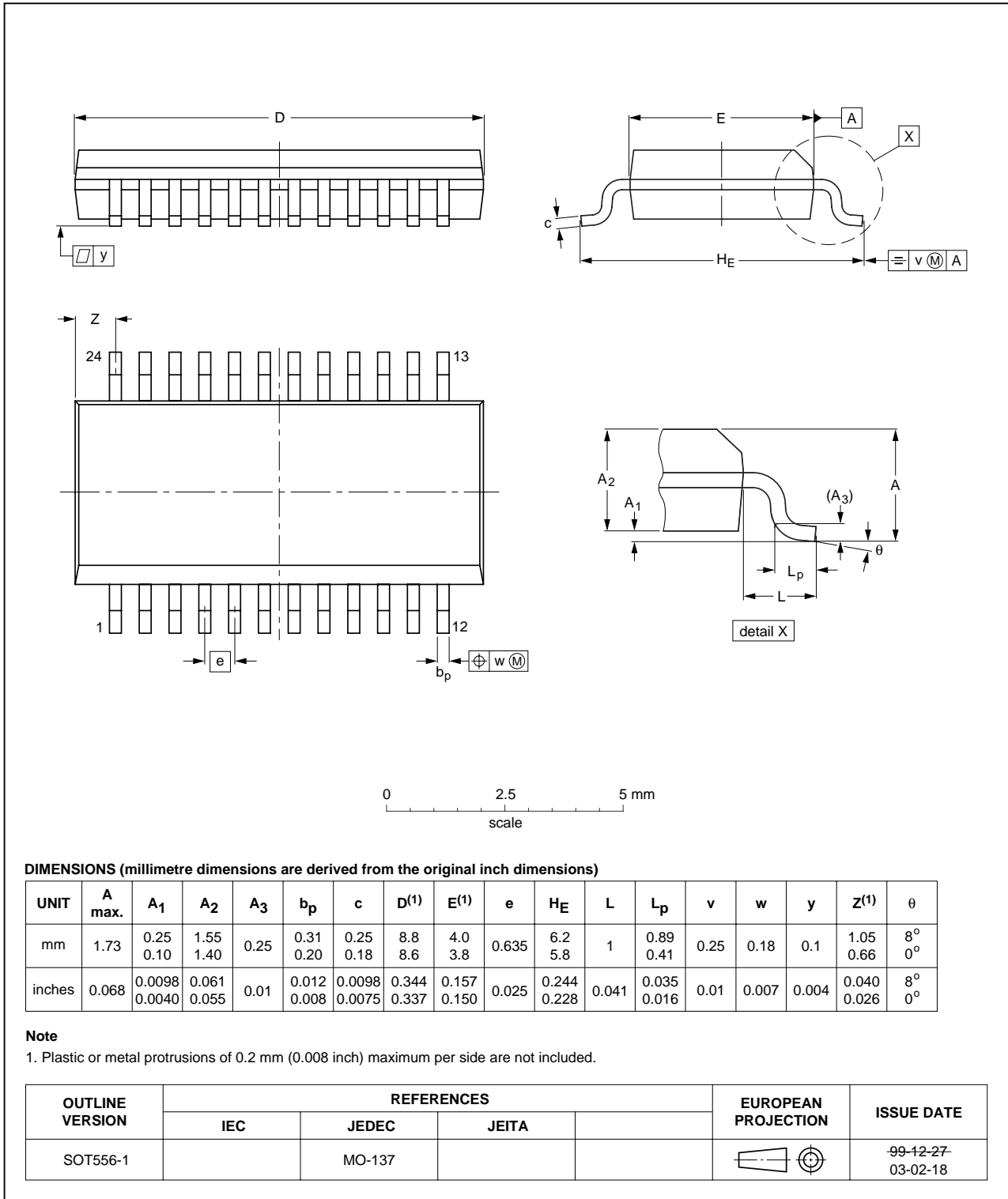

Fig 10. Package outline SOT556-1 (SSOP24)

TSSOP24: plastic thin shrink small outline package; 24 leads; body width 4.4 mm

SOT355-1

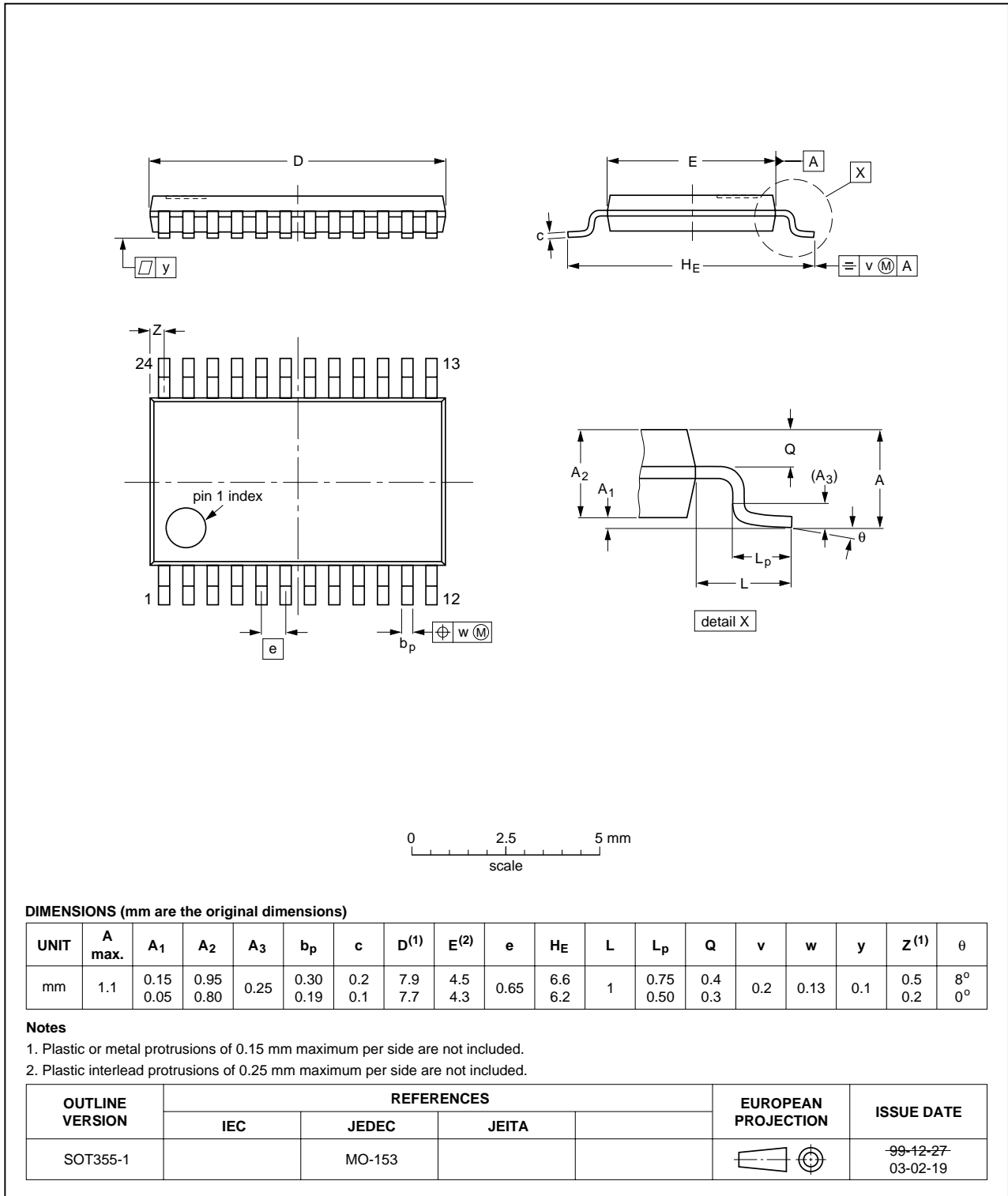

Fig 11. Package outline SOT355-1 (TSSOP24)

14. Abbreviations

Table 10. Abbreviations

Acronym	Description
CDM	Charged Device Model
DUT	Device Under Test
ESD	ElectroStatic Discharge
FET	Field Effect Transistor
HBM	Human Body Model
PRR	Pulse Rate Repetition
TTL	Transistor-Transistor Logic

15. Revision history

Table 11. Revision history

Document ID	Release date	Data sheet status	Change notice	Supersedes
CBT3384_6	20091102	Product data sheet	-	CBT3384_5
Modifications:	<ul style="list-style-type: none"> • The format of this data sheet has been redesigned to comply with the new identity guidelines of NXP Semiconductors. • Legal texts have been adapted to the new company name where appropriate. • Changed: Table 6 “Static characteristics” <ol style="list-style-type: none"> a. Pass voltage values have changed. b. Undershoot static current protection removed. • Changed: Table 7 “Dynamic characteristics” <ol style="list-style-type: none"> a. Enable and disable times values have changed. 			
CBT3384_5	20011220	Product specification	-	CBT3384_4
CBT3384_4	20010319	Product specification	-	CBT3384_3
CBT3384_3	20001113	Product specification	-	CBT3384_2
CBT3384_2	20000128	Product specification	-	-

16. Legal information

16.1 Data sheet status

Document status ^{[1][2]}	Product status ^[3]	Definition
Objective [short] data sheet	Development	This document contains data from the objective specification for product development.
Preliminary [short] data sheet	Qualification	This document contains data from the preliminary specification.
Product [short] data sheet	Production	This document contains the product specification.

[1] Please consult the most recently issued document before initiating or completing a design.

[2] The term 'short data sheet' is explained in section "Definitions".

[3] The product status of device(s) described in this document may have changed since this document was published and may differ in case of multiple devices. The latest product status information is available on the Internet at URL <http://www.nxp.com>.

16.2 Definitions

Draft — The document is a draft version only. The content is still under internal review and subject to formal approval, which may result in modifications or additions. NXP Semiconductors does not give any representations or warranties as to the accuracy or completeness of information included herein and shall have no liability for the consequences of use of such information.

Short data sheet — A short data sheet is an extract from a full data sheet with the same product type number(s) and title. A short data sheet is intended for quick reference only and should not be relied upon to contain detailed and full information. For detailed and full information see the relevant full data sheet, which is available on request via the local NXP Semiconductors sales office. In case of any inconsistency or conflict with the short data sheet, the full data sheet shall prevail.

16.3 Disclaimers

General — Information in this document is believed to be accurate and reliable. However, NXP Semiconductors does not give any representations or warranties, expressed or implied, as to the accuracy or completeness of such information and shall have no liability for the consequences of use of such information.

Right to make changes — NXP Semiconductors reserves the right to make changes to information published in this document, including without limitation specifications and product descriptions, at any time and without notice. This document supersedes and replaces all information supplied prior to the publication hereof.

Suitability for use — NXP Semiconductors products are not designed, authorized or warranted to be suitable for use in medical, military, aircraft, space or life support equipment, nor in applications where failure or malfunction of an NXP Semiconductors product can reasonably be expected to result in personal injury, death or severe property or environmental

damage. NXP Semiconductors accepts no liability for inclusion and/or use of NXP Semiconductors products in such equipment or applications and therefore such inclusion and/or use is at the customer's own risk.

Applications — Applications that are described herein for any of these products are for illustrative purposes only. NXP Semiconductors makes no representation or warranty that such applications will be suitable for the specified use without further testing or modification.

Limiting values — Stress above one or more limiting values (as defined in the Absolute Maximum Ratings System of IEC 60134) may cause permanent damage to the device. Limiting values are stress ratings only and operation of the device at these or any other conditions above those given in the Characteristics sections of this document is not implied. Exposure to limiting values for extended periods may affect device reliability.

Terms and conditions of sale — NXP Semiconductors products are sold subject to the general terms and conditions of commercial sale, as published at <http://www.nxp.com/profile/terms>, including those pertaining to warranty, intellectual property rights infringement and limitation of liability, unless explicitly otherwise agreed to in writing by NXP Semiconductors. In case of any inconsistency or conflict between information in this document and such terms and conditions, the latter will prevail.

No offer to sell or license — Nothing in this document may be interpreted or construed as an offer to sell products that is open for acceptance or the grant, conveyance or implication of any license under any copyrights, patents or other industrial or intellectual property rights.

Export control — This document as well as the item(s) described herein may be subject to export control regulations. Export might require a prior authorization from national authorities.

16.4 Trademarks

Notice: All referenced brands, product names, service names and trademarks are the property of their respective owners.

17. Contact information

For more information, please visit: <http://www.nxp.com>

For sales office addresses, please send an email to: salesaddresses@nxp.com

18. Contents

1 General description 1

2 Features 1

3 Ordering information 1

4 Functional diagram 2

5 Pinning information 2

5.1 Pinning 2

5.2 Pin description 3

6 Functional description 3

7 Limiting values 4

8 Recommended operating conditions 4

9 Static characteristics 4

10 Dynamic characteristics 5

11 Waveforms 6

12 Test information 7

13 Package outline 8

14 Abbreviations 12

15 Revision history 12

16 Legal information 13

16.1 Data sheet status 13

16.2 Definitions 13

16.3 Disclaimers 13

16.4 Trademarks 13

17 Contact information 13

18 Contents 14

Please be aware that important notices concerning this document and the product(s) described herein, have been included in section 'Legal information'.



© NXP B.V. 2009.

All rights reserved.

For more information, please visit: <http://www.nxp.com>

For sales office addresses, please send an email to: salesaddresses@nxp.com

Date of release: 2 November 2009

Document identifier: CBT3384_6