

# DATA SHEET

## **CBT3125** Quadruple FET bus switch

Product data

2001 Dec 12

File under Integrated Circuits — ICL03

# Quadruple FET bus switch

# CBT3125

## DESCRIPTION

The CBT3125 quadruple FET bus switch features independent line switches. Each switch is disabled when the associated Output Enable ( $\overline{OE}$ ) input is HIGH.

## FEATURES

- Standard '125-type pinout (D, DB, and PW packages)
- 5  $\Omega$  switch connection between two ports
- TTL-compatible input levels
- Latch-up testing is done to JESDEC Standard JESD78 which exceeds 500 mA
- ESD protection exceeds 2000 V HBM per JESD22-A114, 200 V MM per JESD22-A115, and 1000 V CDM per JESD22-C101

## PIN CONFIGURATION

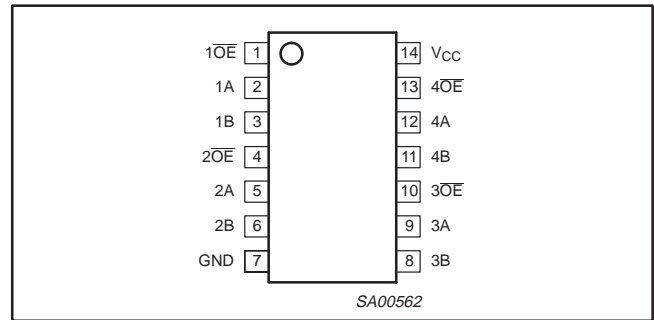
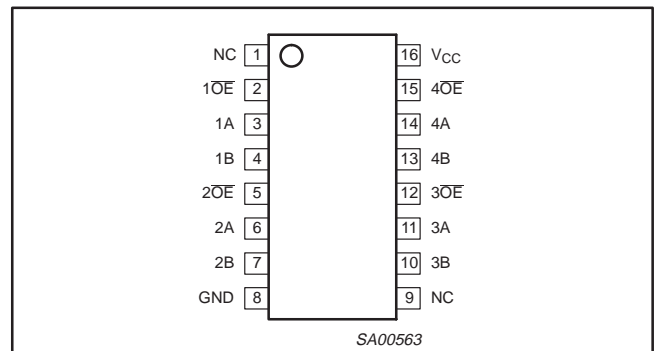

Figure 1. SO14, SSOP14, and TSSOP14



NC = no internal connection

Figure 2. SSOP(QSOP)16

## ORDERING INFORMATION

PACKAGES	TEMPERATURE RANGE	ORDER CODE	DRAWING NUMBER
14-Pin Plastic SO	-40 to +85 °C	CBT3125D	SOT108-1
14-Pin Plastic SSOP	-40 to +85 °C	CBT3125DB	SOT337-1
16-Pin Plastic SSOP(QSOP)	-40 to +85 °C	CBT3125DS	SOT519-1
14-Pin Plastic TSSOP	-40 to +85 °C	CBT3125PW	SOT402-1

Standard packing quantities and other packaging data is available at [www.philipslogic.com/packaging](http://www.philipslogic.com/packaging).

# Quadruple FET bus switch

# CBT3125

## LOGIC DIAGRAM

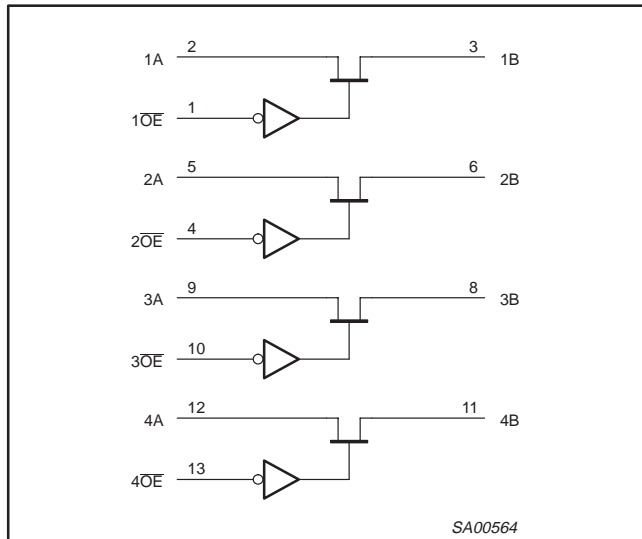

Pin numbers shown are for 14-pin package-types.

**Figure 3. CBT3125 logic diagram (positive logic)**

## FUNCTION TABLE (each bus switch)

INPUT OE	FUNCTION
L	A = B
H	disconnect

## ABSOLUTE MAXIMUM RATINGS<sup>1</sup>

Over operating free-air temperature range, unless otherwise noted.

SYMBOL	PARAMETER	CONDITIONS	MIN.	MAX.	UNIT
$V_{CC}$	supply voltage range		-0.5	7	V
$V_I$	input voltage range	see Note 2	-0.5	7	V
	continuous channel current		—	128	mA
$I_K$	input clamp current	$V_{I/O} < 0$	—	-50	mA
$T_{stg}$	storage temperature range		-65	+150	°C

### NOTES:

- Stresses beyond those listed under "absolute maximum ratings" may cause permanent damage to the device. These are stress ratings only, and functional operation of the device at these or any other conditions beyond those indicated under "recommended operating conditions" is not implied. Exposure to absolute-maximum-rated conditions for extended periods may affect device reliability.
- The input and output negative-voltage ratings may be exceeded if the input and output clamp-current ratings are observed.
- The package thermal impedance is calculated in accordance with JESD 51-7.

## RECOMMENDED OPERATING CONDITIONS<sup>1</sup>

SYMBOL	PARAMETER	CONDITIONS	MIN.	MAX.	UNIT
$V_{CC}$	supply voltage		4.5	5.5	V
$V_{IH}$	high-level control input voltage		2	—	V
$V_{IL}$	low-level control input voltage		—	0.8	V
$T_{amb}$	operating ambient temperature in free-air		-40	+85	°C

### NOTE:

- All unused control inputs of the device must be held at  $V_{CC}$  or GND to ensure proper device operation.

# Quadruple FET bus switch

# CBT3125

## DC ELECTRICAL CHARACTERISTICS

Over recommended operating free-air temperature range, unless otherwise noted.

SYMBOL	PARAMETER		CONDITIONS	MIN.	TYP. <sup>1</sup>	MAX.	UNIT
$V_{IK}$	Input clamp voltage		$V_{CC} = 4.5\text{ V};$ $I_I = -18\text{ mA}$	—	—	-1.2	V
$I_I$	Input leakage current		$V_{CC} = 5.5\text{ V};$ $V_I = 5.5\text{ V or GND}$	—	—	$\pm 1$	$\mu\text{A}$
$I_{CC}$	Quiescent supply current		$V_{CC} = 5.5\text{ V}; I_O = 0;$ $V_I = V_{CC} \text{ or GND}$	—	—	3	$\mu\text{A}$
$\Delta I_{CC}$	Additional supply current per input pin (Note 2)	control inputs	$V_{CC} = 5.5\text{ V};$ one input at 3.4 V, other inputs at $V_{CC}$ or GND	—	—	2.5	mA
$C_I$	Input capacitance	control inputs	$V_I = 3\text{ V or } 0$	—	1.7	—	pF
$C_{IO(OFF)}$	Power-off leakage current		$V_O = 3\text{ V or } 0; \overline{OE} = V_{CC}$	—	3.4	—	pF
$V_P$	Pass gate voltage		$V_{CC} = 5.0\text{ V}; V_I = 5.0\text{ V}$	—	3.8	—	V
$r_{on}$	On-resistance (Note 3)		$V_{CC} = 4.5\text{ V}; V_I = 0\text{ V};$ $I_I = 64\text{ mA}$	—	5	7	$\Omega$
			$V_{CC} = 4.5\text{ V}; V_I = 0\text{ V};$ $I_I = 30\text{ mA}$	—	5	7	$\Omega$
			$V_{CC} = 4.5\text{ V}; V_I = 2.4\text{ V};$ $I_I = -15\text{ mA}$	—	10	15	$\Omega$

### NOTES:

- All typical values are at  $V_{CC} = 5\text{ V}$ , unless otherwise noted.  $T_{amb} = 25\text{ }^\circ\text{C}$ .
- This is the increase in supply current for each input that is at the specified TTL voltage level rather than  $V_{CC}$  or GND.
- Measured by the voltage drop between the A and the B terminals at the indicated current through the switch. On-state resistance is determined by the lower of the voltages of the two (A or B) terminals.

## AC CHARACTERISTICS

$T_{amb} = -40\text{ to } +85\text{ }^\circ\text{C}; C_L = 50\text{ pF}$ , unless otherwise noted.

SYMBOL	PARAMETER	FROM (INPUT)	TO (OUTPUT)	$V_{CC} = 5\text{ V} \pm 0.5\text{ V}$		UNIT
				Min	Max	
$t_{pd}$	Propagation delay <sup>1</sup>	A or B	B or A	—	0.25	ns
$t_{en}$	Output enable time to High and Low level	$\overline{OE}$	A or B	1.0	5.4	ns
$t_{dis}$	Output disable time from High and Low level	$\overline{OE}$	A or B	1	4.7	ns

### NOTE:

- This parameter is warranted but not production tested. The propagation delay is based on the RC time constant of the typical on-state resistance of the switch and a load capacitance of 50 pF, when driven by an ideal voltage source (zero output impedance).

# Quadruple FET bus switch

CBT3125

## AC WAVEFORMS

$V_M = 1.5\text{ V}$ ,  $V_{IN} = \text{GND to } 3.0\text{V}$

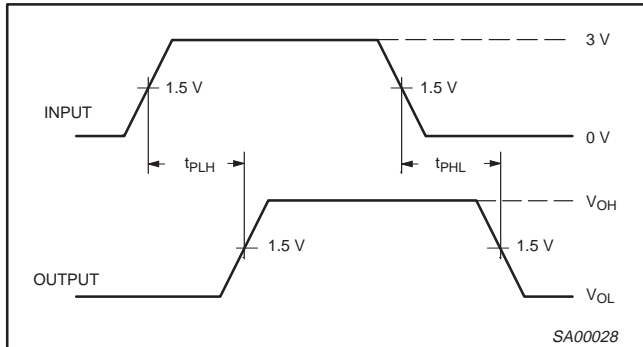

$t_{PLH}$  and  $t_{PHL}$  are the same as  $t_{pd}$ .

**Waveform 1. Input to Output Propagation Delays**

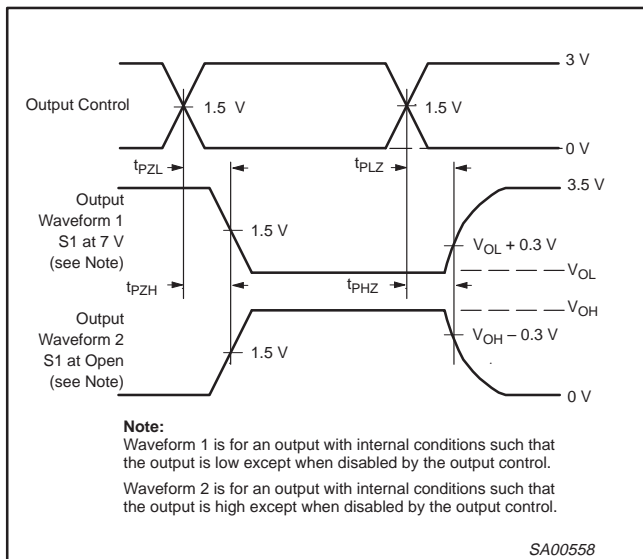

**Note:**  
Waveform 1 is for an output with internal conditions such that the output is low except when disabled by the output control.  
Waveform 2 is for an output with internal conditions such that the output is high except when disabled by the output control.

$t_{PLZ}$  and  $t_{PHZ}$  are the same as  $t_{dis}$ .

$t_{PZL}$  and  $t_{PZH}$  are the same as  $t_{en}$ .

**Waveform 2. Output Enable and Disable Times**

## TEST CIRCUIT

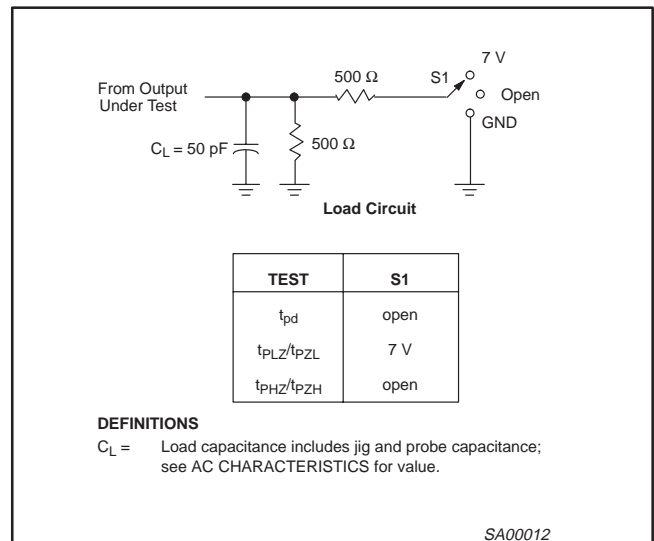

### DEFINITIONS

$C_L =$  Load capacitance includes jig and probe capacitance; see AC CHARACTERISTICS for value.

$t_{PLZ}$  and  $t_{PHZ}$  are the same as  $t_{dis}$ .

$t_{PZL}$  and  $t_{PZH}$  are the same as  $t_{en}$ .

### NOTES:

- All input pulses are supplied by generators having the following characteristics:  $PRR \leq 10\text{ MHz}$ ,  $Z_O = 50\ \Omega$ ,  $t_r \leq 2.5\text{ ns}$ ,  $t_f \leq 2.5\text{ ns}$ .
- The outputs are measured one at a time with one transition per measurement.

# Quadruple FET bus switch

# CBT3125

**SO14: plastic small outline package; 14 leads; body width 3.9 mm**

**SOT108-1**

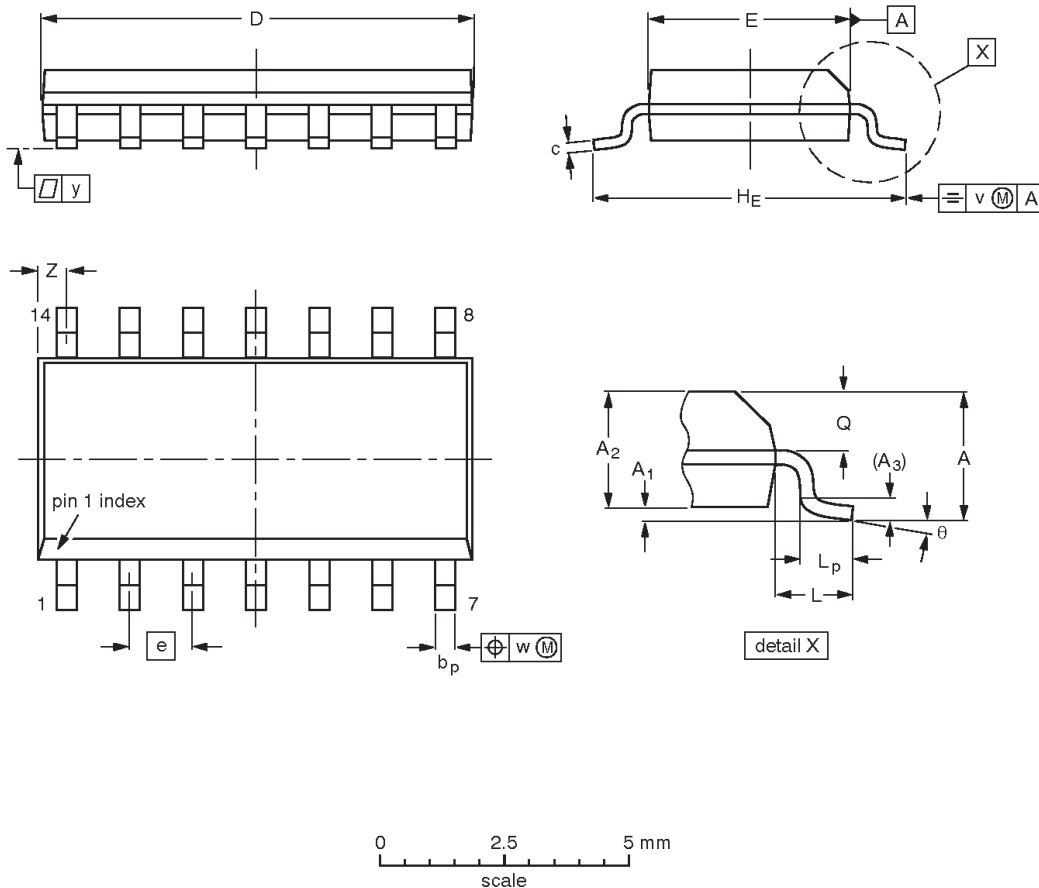

**DIMENSIONS (inch dimensions are derived from the original mm dimensions)**

UNIT	A max.	A <sub>1</sub>	A <sub>2</sub>	A <sub>3</sub>	b <sub>p</sub>	c	D <sup>(1)</sup>	E <sup>(1)</sup>	e	H <sub>E</sub>	L	L <sub>p</sub>	Q	v	w	y	Z <sup>(1)</sup>	θ
mm	1.75	0.25 0.10	1.45 1.25	0.25	0.49 0.36	0.25 0.19	8.75 8.55	4.0 3.8	1.27	6.2 5.8	1.05	1.0 0.4	0.7 0.6	0.25	0.25	0.1	0.7 0.3	8° 0°
inches	0.069	0.010 0.004	0.057 0.049	0.01	0.019 0.014	0.0100 0.0075	0.35 0.34	0.16 0.15	0.050	0.244 0.228	0.041	0.039 0.016	0.028 0.024	0.01	0.01	0.004	0.028 0.012	

**Note**

1. Plastic or metal protrusions of 0.15 mm maximum per side are not included.

OUTLINE VERSION	REFERENCES				EUROPEAN PROJECTION	ISSUE DATE
	IEC	JEDEC	EIAJ			
SOT108-1	076E06	MS-012				97-05-22 99-12-27

# Quadruple FET bus switch

CBT3125

SSOP14: plastic shrink small outline package; 14 leads; body width 5.3 mm

SOT337-1

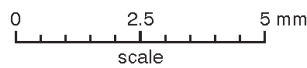
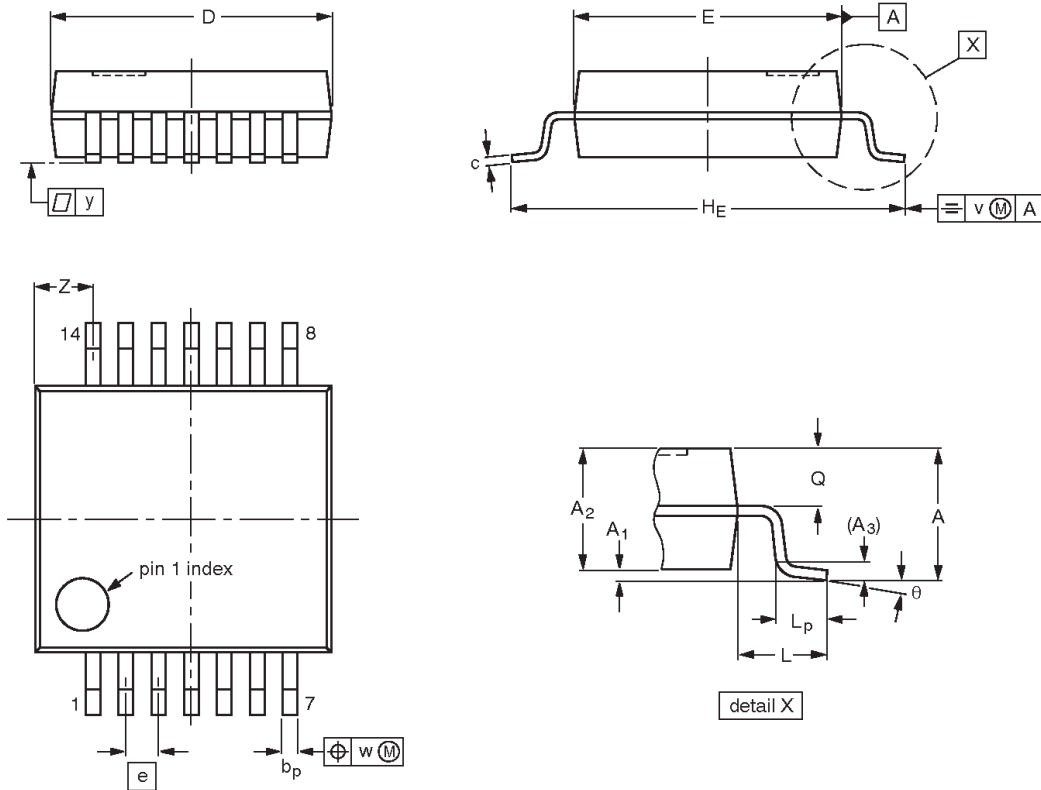

**DIMENSIONS (mm are the original dimensions)**

UNIT	A max.	A <sub>1</sub>	A <sub>2</sub>	A <sub>3</sub>	b <sub>p</sub>	c	D <sup>(1)</sup>	E <sup>(1)</sup>	e	H <sub>E</sub>	L	L <sub>p</sub>	Q	v	w	y	Z <sup>(1)</sup>	θ
mm	2.0	0.21 0.05	1.80 1.65	0.25	0.38 0.25	0.20 0.09	6.4 6.0	5.4 5.2	0.65	7.9 7.6	1.25	1.03 0.63	0.9 0.7	0.2	0.13	0.1	1.4 0.9	8° 0°

**Note**

1. Plastic or metal protrusions of 0.25 mm maximum per side are not included.

OUTLINE VERSION	REFERENCES				EUROPEAN PROJECTION	ISSUE DATE
	IEC	JEDEC	EIAJ			
SOT337-1		MO-150				96-01-18 99-12-27

# Quadruple FET bus switch

CBT3125

**SSOP16:** plastic shrink small outline package; 16 leads;  
body width 3.9 mm; lead pitch 0.635 mm

**SOT519-1**

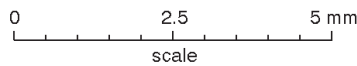
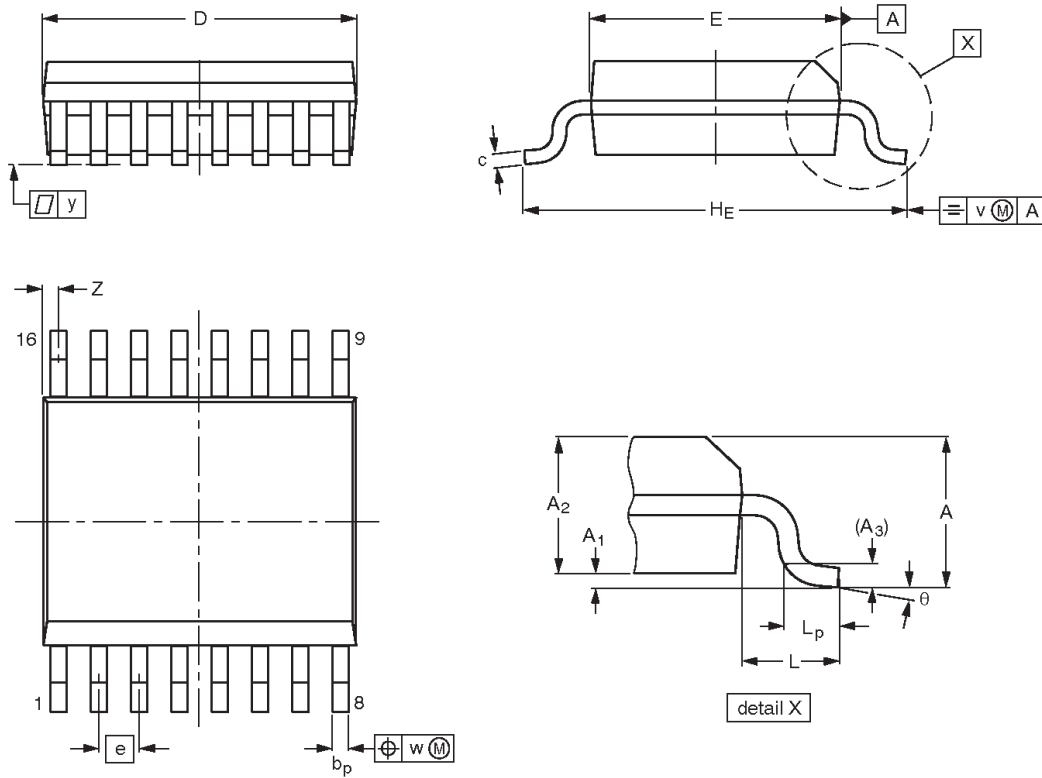

**DIMENSIONS (mm are the original dimensions)**

UNIT	A max.	A <sub>1</sub>	A <sub>2</sub>	A <sub>3</sub>	b <sub>p</sub>	c	D <sup>(1)</sup>	E <sup>(1)</sup>	e	H <sub>E</sub>	L	L <sub>p</sub>	v	w	y	Z <sup>(1)</sup>	θ
mm	1.73	0.25 0.10	1.55 1.40	0.25	0.31 0.20	0.25 0.18	5.0 4.8	4.0 3.8	0.635	6.2 5.8	1.0	0.89 0.41	0.2	0.18	0.09	0.18 0.05	8° 0°

**Note**

1. Plastic or metal protrusions of 0.20 mm maximum per side are not included.

OUTLINE VERSION	REFERENCES				EUROPEAN PROJECTION	ISSUE DATE
	IEC	JEDEC	EIAJ			
SOT519-1						99-05-04

# Quadruple FET bus switch

# CBT3125

**TSSOP14:** plastic thin shrink small outline package; 14 leads; body width 4.4 mm

**SOT402-1**

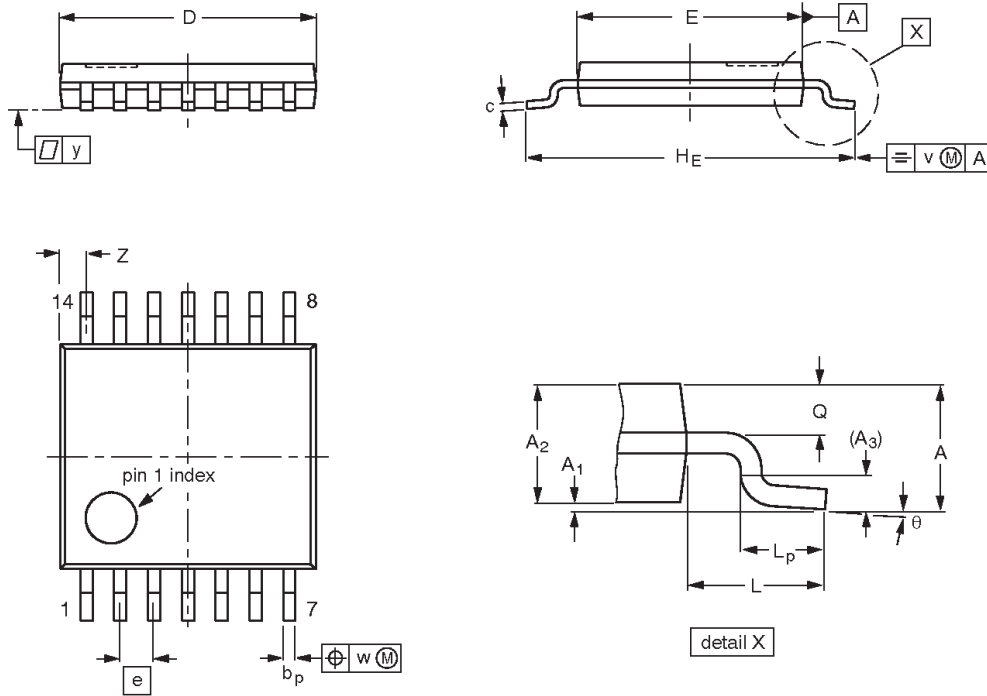

**DIMENSIONS (mm are the original dimensions)**

UNIT	A max.	A <sub>1</sub>	A <sub>2</sub>	A <sub>3</sub>	b <sub>p</sub>	c	D <sup>(1)</sup>	E <sup>(2)</sup>	e	H <sub>E</sub>	L	L <sub>p</sub>	Q	v	w	y	Z <sup>(1)</sup>	θ
mm	1.10	0.15 0.05	0.95 0.80	0.25	0.30 0.19	0.2 0.1	5.1 4.9	4.5 4.3	0.65	6.6 6.2	1.0	0.75 0.50	0.4 0.3	0.2	0.13	0.1	0.72 0.38	8° 0°

**Notes**

1. Plastic or metal protrusions of 0.15 mm maximum per side are not included.
2. Plastic interlead protrusions of 0.25 mm maximum per side are not included.

OUTLINE VERSION	REFERENCES				EUROPEAN PROJECTION	ISSUE DATE
	IEC	JEDEC	EIAJ			
SOT402-1		MO-153				-95-04-04 99-12-27

# Quadruple FET bus switch

# CBT3125

## Data sheet status

Data sheet status <sup>[1]</sup>	Product status <sup>[2]</sup>	Definitions
Objective data	Development	This data sheet contains data from the objective specification for product development. Philips Semiconductors reserves the right to change the specification in any manner without notice.
Preliminary data	Qualification	This data sheet contains data from the preliminary specification. Supplementary data will be published at a later date. Philips Semiconductors reserves the right to change the specification without notice, in order to improve the design and supply the best possible product.
Product data	Production	This data sheet contains data from the product specification. Philips Semiconductors reserves the right to make changes at any time in order to improve the design, manufacturing and supply. Changes will be communicated according to the Customer Product/Process Change Notification (CPCN) procedure SNW-SQ-650A.

[1] Please consult the most recently issued data sheet before initiating or completing a design.

[2] The product status of the device(s) described in this data sheet may have changed since this data sheet was published. The latest information is available on the Internet at URL <http://www.semiconductors.philips.com>.

## Definitions

**Short-form specification** — The data in a short-form specification is extracted from a full data sheet with the same type number and title. For detailed information see the relevant data sheet or data handbook.

**Limiting values definition** — Limiting values given are in accordance with the Absolute Maximum Rating System (IEC 60134). Stress above one or more of the limiting values may cause permanent damage to the device. These are stress ratings only and operation of the device at these or at any other conditions above those given in the Characteristics sections of the specification is not implied. Exposure to limiting values for extended periods may affect device reliability.

**Application information** — Applications that are described herein for any of these products are for illustrative purposes only. Philips Semiconductors make no representation or warranty that such applications will be suitable for the specified use without further testing or modification.

## Disclaimers

**Life support** — These products are not designed for use in life support appliances, devices or systems where malfunction of these products can reasonably be expected to result in personal injury. Philips Semiconductors customers using or selling these products for use in such applications do so at their own risk and agree to fully indemnify Philips Semiconductors for any damages resulting from such application.

**Right to make changes** — Philips Semiconductors reserves the right to make changes, without notice, in the products, including circuits, standard cells, and/or software, described or contained herein in order to improve design and/or performance. Philips Semiconductors assumes no responsibility or liability for the use of any of these products, conveys no license or title under any patent, copyright, or mask work right to these products, and makes no representations or warranties that these products are free from patent, copyright, or mask work right infringement, unless otherwise specified.

## Contact information

For additional information please visit  
<http://www.semiconductors.philips.com>. Fax: +31 40 27 24825

© Koninklijke Philips Electronics N.V. 2001  
 All rights reserved. Printed in U.S.A.

Date of release: 12-01

For sales offices addresses send e-mail to:  
[sales.addresses@www.semiconductors.philips.com](mailto:sales.addresses@www.semiconductors.philips.com)

Document order number:

9397 750 09218

*Let's make things better.*