

# Control & Monitoring Relays

## Single Phase Voltage Relay MXV-10



### DESCRIPTION

Single phase voltage relay for detecting AC/DC over-or under-voltage. The relay is delivered in two variations for over-and under-voltage.

**Over-voltage:**

When the monitored voltage rises and reaches the determined setpoint, which is adjusted on the front panel, the relay energises. When the voltage drops and passes the setpoint, minus the hysteresis which is adjustable on the front, the relay de-energises.

**Under-voltage:**

When the monitored voltage drops and reaches the determined setpoint, which is adjusted on the front panel, the relay energises. When the voltage rises and passes the setpoint, plus the hysteresis which is adjustable on the front, the relay de-energises.

There is also a latch function where the relay after energising will remain energised, regardless of input voltage, until the latch jumper or the operating voltage is disconnected. Typically used in safety circuits. The contact function of the relay can also be inverted.

The relay has an analogue, 2-10VDC, output which when connected to an external voltmeter can be used for the accurate adjustment of the setpoint.

### Features

- Monitoring of 1-500VAC/DC in 5 ranges in one version.
- Adjustable setpoint.
- Adjustable hysteresis of 0,5-20%.
- Automatic locking function (latch).
- Inversion of the relay function.
- Output SPDT and 2-10VDC with reference to setpoint.
- Supply voltage 24VDC, 24/115VAC or 24/230VAC.

### VERSIONS/ORDERING CODES

|   |        |        |     |   |
|---|--------|--------|-----|---|
| <b>Type:</b><br>Single phase voltage relay                              | MXV-10 | MXV-10 | 230 | 1 |
| <b>Supply voltage</b><br>24V DC<br>115V AC / 24V AC<br>230V AC / 24V AC | 924    | 115    | 230 |   |
| <b>Over/under voltage</b><br>Over voltage<br>Under voltage              | 1      | 2      |     |   |

### OPERATION

#### Over voltage, code 1

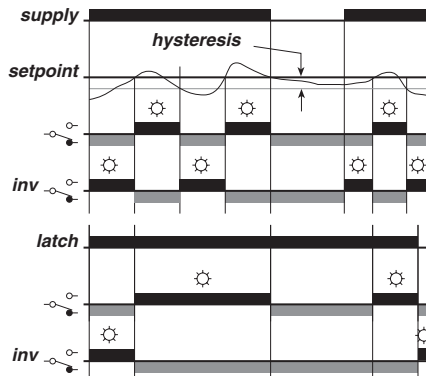

#### Under voltage, code 2

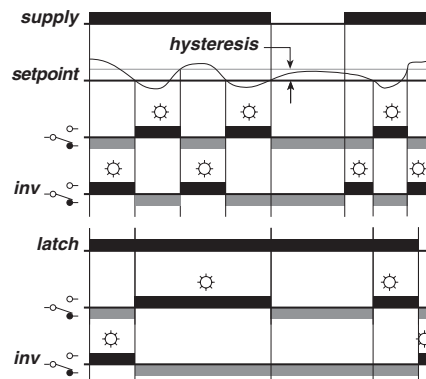

### MECHANICAL DIMENSIONS

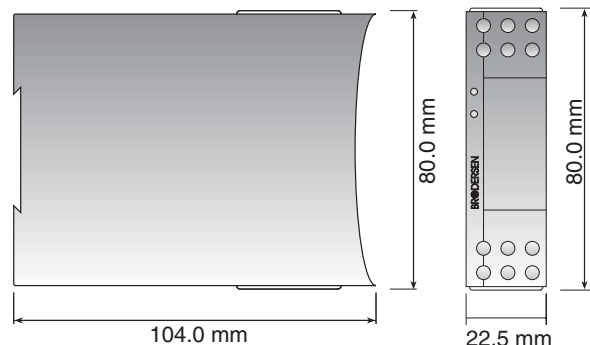

## TECHNICAL DATA

### Input:

| Input signal   | Impedance | U <sub>max</sub> |
|----------------|-----------|------------------|
| 1-5V AC/DC     | 500k      | 700V AC          |
| 4-20V AC/DC    | 500k      | 700V AC          |
| 10-50V AC/DC   | 500k      | 700V AC          |
| 40-200V AC/DC  | 500k      | 700V AC          |
| 100-500V AC/DC | 500k      | 700V AC          |

|                   |   |
|-------------------|---|
| Frequency :       | 45-65 Hz  |
| Temperature drift | Max. 0,05%/°C   |
| Setting accuracy: | Typically ± 10%   |
| Hysteresis:       | 0,5-20% of chosen range, adjustable   |
| Response time:    | time constant $\tau = 0,8s$ ,<br>Worst case of response time max. $5 \times \tau$ |

### Output:

|             |  |
|-------------|--|
| SPDT relay: | Contact material, AgNi 0,15 with hardened gold plating Au.<br>Max load AC, 8A/240V AC ( $\cos\phi=1$ )<br>Max. breaking capacity 2000VA.<br>Inductive load. See fig. 1.<br>Max load DC, 8A/24V DC<br>Max breaking capacity 50-270W see fig. 2. |
|-------------|--|

|                       |  |
|-----------------------|--|
| Max. in rush current: | 15A (max. 4s/duty cycle less than 10%).  |
| Min. in rush current: | 10mA, 24V DC.  |
| Frequency :           | Max. 1000 operations pr. hour.   |
| Life span:            | Mech. Min. $3 \times 10^7$ operations<br>Elect. Min $1 \times 10^5$ operations with full load.<br><20ms.                   |
| Delay;                | <20ms.   |
| Analogue output:      | 2-10V DC, refers to setpoint in chosen range.<br>$I_{max} = 2mA / R_{load} > 5k\Omega$ .<br>Accuracy better than +/- 0,5%. |

### Supply voltage:

|                |  |
|----------------|--|
| Versions:      | 924=24V DC (20,4-27,6)V DC.<br>115=24/115V AC (20,4-27,6/98-132)V AC.<br>230=24/230V AC (20,4-27,6/196-264)V AC. |
| Net frequency: | 45-65Hz.   |
| Consumption:   | AC; 3VA<br>DC; 2W  |

### General data::

|                       |  |
|-----------------------|--|
| Ambient temperature:  | -20 to 55°C.   |
| Storage temperature:  | -40 to 80°C.   |
| Mounting:             | 35mm DIN-rail (EN50022).   |
| Terminals:            | Screw terminals with dual compartment.<br>Terminal screws are combined crosshead/slotted. Up to 2 x 2,5mm <sup>2</sup> wire (2 x 1,5mm <sup>2</sup> inc. ferrule).<br>Recommended torque, 0,5Nm.<br>Max 0,7 Nm. (VDE0609-1).<br>Terminal identification in accordance with DIN46199/EN50005. |
| Indicators:           | Green LED = operating voltage.<br>Red LED = relay switched on.   |
| Protection:           | IP20.  |
| Electrical isolation: | 3,75kVAC (1 min.) between input, supply and relay output (EN60950).<br><b>Note:</b> No galvanic isolation between input and analogue output.   |
| Housing:              | Noryl (GE), UL94V1.  |
| Terminal block:       | Noryl (GE), UL94V0.  |
| Weight:               | 180 g.   |

## WIRING DIAGRAM

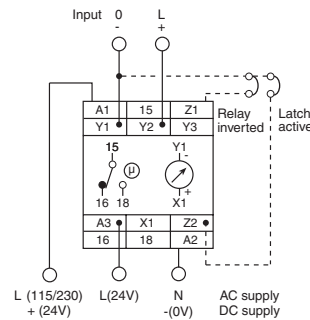

**Coding:**  
Relay inv.; Jumper Y1 - Z1  
Latching; Jumper Y1 - Z2

**Analogue output 2-10V DC;**  
X1 = (+) V  
Y1 = (-) 0

## SPECIFICATIONS

MXV-10 is designed and developed with regard to relevant specifications:

- EN62024-1 / VDE0113 electrical material on machines.
- VDE0110 / IEC664 Isolation specifications/creepage and clearance distances.
- Electrical safety in accordance with EN61010.
- IEC414 Safety regulations for control and monitoring equipment.
- EMC: Emission EN50081-1.  
Immunity EN50082-2.
- Humidity in accordance with IEC68-2-3; RH=95%, 40°C.
- Vibration in accordance with IEC68-2-6;
- Shock when mounted, in accordance with IEC68-2-27.

MXV-10 is CE-marked in accordance with EMC-and the Low Voltage Directive.

## OUTPUT LOAD DIAGRAMS

Fig. 1

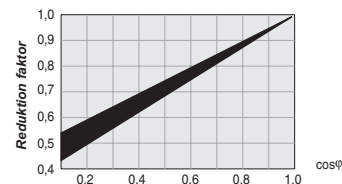

Fig. 2

