



80x80x25mm

- **Airflow: 27.9~48.5 CFM**
- **Static Pressure: 1.3~3.8 mm-H₂O**
- **Blade / Housing:**
Plastic Material UL 94V-0 P.B.T.
- **Lead Wire: UL1007 #24 AWG**
- **Weight: 88 g**

Model No.	Bearing	Rated Voltage	Operating Voltage Range	Speed	Max. Airflow	Max. Static Pressure	Current	Power Consumption	Life at 40°C L10	P-Q Curve	Noise Level
		VDC	VDC	RPM	CFM	mm-H ₂ O	mA	W	Hour		dB(A)
YW08025012SL	S		7~13.2	1900	27.9	1.3	100	1.20	30000	4	22.5
YW08025012SM	S		7~13.2	2400	35.4	2.1	160	1.92	30000	3	27.5
YW08025012SH	S		7~13.2	2900	43.7	2.9	230	2.76	25000	2	33.5
YW08025012SS	S		7~13.2	3200	47.4	3.6	260	3.12	20000	1	36.0
YW08025012BL	2B	12	7~13.2	2000	30.0	1.5	100	1.20	80000	4	23.5
YW08025012BM	2B		7~13.2	2500	37.0	2.1	160	1.92	80000	3	30.0
YW08025012BH	2B		7~13.2	3000	45.2	3.1	230	2.76	75000	2	34.5
YW08025012BS	2B		7~13.2	3300	48.5	3.8	260	3.12	65000	1	37.0
YW08025024BL	2B	24	12~26.4	2000	30.0	1.5	60	1.44	80000	4	23.5
YW08025024BM	2B		12~26.4	2500	37.0	2.2	80	1.92	80000	3	30.0
YW08025024BH	2B		12~26.4	3000	45.2	3.1	130	3.12	75000	2	34.5
YW08025048BL	2B	48	24~56.0	2000	30.0	1.5	30	1.44	80000	4	23.5
YW08025048BM	2B		24~56.0	2500	37.0	2.2	50	2.40	80000	3	30.0
YYW08025048BH	2B		24~56.0	3000	45.2	3.1	90	4.08	80000	2	34.5
YYW08025048BS	2B		24~56.0	3300	48.5	3.8	110	5.28	65000	1	37.0

Buy Now

2B: 2-ball bearing L: sintetico bearing S: sleeve bearing

Voltage Available

Bearing System Available

Function Available

05 12 24 48

2B L S

1 6 5 4 3 2 7 8 9 10 11 14 12 13

PERFORMANCE P-Q CURVE

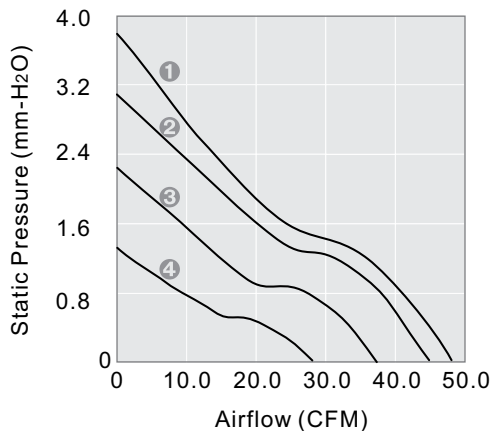

OUTLINE DIMENSIONS

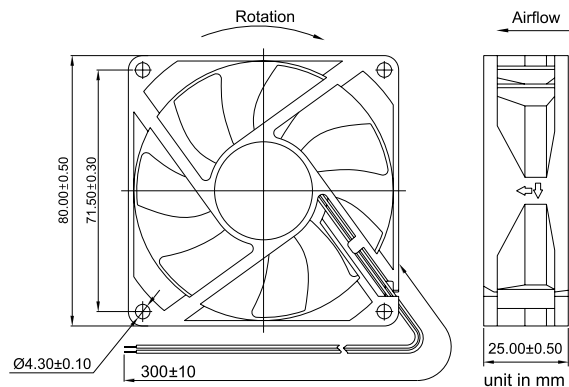

Please refer to *Model Numbering System* for bearing, function and speed level indication. Specifications are subject to changes without notice. Please refer to the formally issued product specification via contacting Y.S. TECH sales department. Visit Y.S. TECH web site at <http://www.ystechusa.com/> for updated information. Customized Specifications are designed accordingly.