



# 80x80x25mm

- Airflow: 26.3~59.6 CFM
- Static Pressure: 2.0~8.8 mm-H<sub>2</sub>O
- Blade / Housing: Plastic Material UL 94V-0 P.B.T.
- Lead Wire: UL1007 #24 AWG
- Weight: 100 g

DC AXIAL FAN

DC BLOWER

Model No.	Bearing	Rated Voltage VDC	Operating Voltage Range VDC	Speed RPM	Max. Airflow CFM	Max. Static Pressure mm-H <sub>2</sub> O	Current mA	Power Consumption W	Life at 40°C L10 Hour	P-Q Curve	Noise Level dB(A)
NYW08025012SL	S	12	7~13.2	2100	26.3	2.0	80	0.96	30000	6	26.0
NYW08025012SM	S	12	7~13.2	2600	32.7	3.1	100	1.56	30000	5	29.5
NYW08025012SH	S	12	7~13.2	3200	40.4	3.9	200	2.40	25000	4	35.5
NYW08025012SS	S	12	7~13.2	3500	46.0	5.2	250	3.00	20000	3	38.5
NYW08025012BL	2B	12	7~13.2	2300	28.8	2.2	80	0.96	80000	6	27.0
NYW08025012BM	2B	12	7~13.2	2900	36.9	3.6	130	1.56	80000	5	32.0
NYW08025012BH	2B	12	7~13.2	3400	41.7	4.5	140	1.68	75000	4	37.5
NYW08025012BS	2B	12	7~13.2	3700	48.5	5.8	250	3.00	65000	3	39.5
NYW08025012BSS	2B	12	7~13.2	4500	59.6	8.8	280	3.36	65000	2	44.0
NYW08025012BU	2B	24	7~13.2	5500	64.1	12.5	500	6.00	65000	1	48.0
NYW08025024BL	2B	24	12~26.4	2300	28.8	2.2	60	1.44	80000	6	27.0
NYW08025024BM	2B	24	12~26.4	2900	36.9	3.6	80	1.92	80000	5	32.0
NYW08025024BH	2B	24	12~26.4	3400	41.7	4.5	100	2.40	75000	4	37.5
NYW08025024BS	2B	24	12~26.4	3700	48.5	5.8	110	2.64	65000	3	39.5
NYW08025024BSS	2B	24	12~26.4	4500	59.6	8.8	200	4.80	65000	2	44.0
NYW08025048BM	2B	48	24~56.0	2900	36.9	3.6	45	2.16	80000	5	32.0
NYW08025048BH	2B	48	24~56.0	3400	41.7	4.5	80	3.84	75000	4	37.5
NYW08025048BS	2B	48	24~56.0	3700	48.5	5.9	90	4.08	75000	3	39.5

Buy Now

2B: 2-ball bearing L: sintetico bearing S: sleeve bearing

Voltage Available

Bearing System Available

Function Available

05 12 24 48

2B L S

1 6 5 4 3 2 7 8 9 10 11 14 12 13

### PERFORMANCE P-Q CURVE

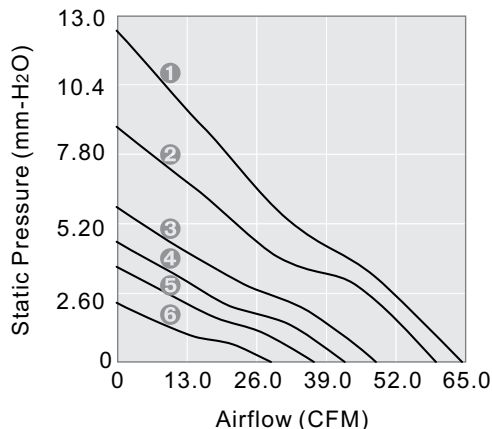

### OUTLINE DIMENSIONS

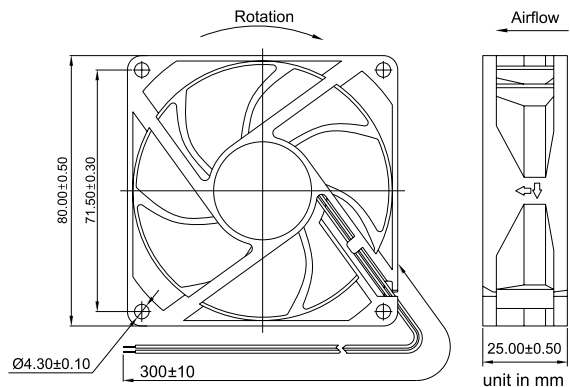

Please refer to *Model Numbering System* for bearing, function and speed level indication. Specifications are subject to changes without notice. Please refer to the formally issued product specification via contacting Y.S. TECH sales department. Visit Y.S. TECH web site at <http://www.ystechusa.com/> for updated information. Customized Specifications are designed accordingly.

XTREME SERIES  
AC AXIAL FAN