



30x30x15mm

- **Airflow:** 3.8~6.1 CFM
- **Static Pressure:** 2.8~7.1 mm-H₂O
- **Blade / Housing:** Plastic Material UL 94V-0 P.B.T.
- **Lead Wire:** UL1571 #28 AWG
- **Weight:** 13 g

DC AXIAL FAN

DC BLOWER

XTREME SERIES

AC AXIAL FAN

| Model No. | Bearing | Rated Voltage VDC | Operating Voltage Range VDC | Speed RPM | Max. Airflow CFM | Max. Static Pressure mm-H ₂ O | Current mA | Power Consumption W | Life at 40°C L10 Hour | P-Q Curve | Noise Level dB(A) |
|---------------|---------|----------------------|--------------------------------|--------------|---------------------|---|---------------|------------------------|--------------------------|-----------|----------------------|
| NYW03015005BL | 2B | 05 | 4~5.5 | 7000 | 3.8 | 2.8 | 60 | 0.30 | 80000 | 4 | <17.0 |
| NYW03015005BM | 2B | | 4~5.5 | 8000 | 4.4 | 3.7 | 85 | 0.425 | 80000 | 3 | 20.5 |
| NYW03015005BH | 2B | | 4~5.5 | 9000 | 4.9 | 4.4 | 110 | 0.55 | 75000 | 2 | 25.0 |
| NYW03015005BS | 2B | | 4~5.5 | 11000 | 5.7 | 6.3 | 200 | 1.00 | 65000 | 1 | 30.0 |
| NYW03015012BL | 2B | 12 | 7~13.2 | 7000 | 3.8 | 2.8 | 30 | 0.36 | 80000 | 4 | <17.0 |
| NYW03015012BM | 2B | | 7~13.2 | 8000 | 4.4 | 3.7 | 40 | 0.48 | 80000 | 3 | 20.5 |
| NYW03015012BH | 2B | | 7~13.2 | 9000 | 4.9 | 4.4 | 45 | 0.54 | 75000 | 2 | 25.0 |
| NYW03015012BS | 2B | | 7~13.2 | 11500 | 6.1 | 7.1 | 90 | 1.08 | 65000 | 1 | 30.0 |

[Buy Now](#)

2B: 2-ball bearing L: sintetico bearing S: sleeve bearing

Voltage Available

05 12 24 48

Bearing System Available

2B L S

Function Available

1 6 5 4 3 2 7 8 9 10 11 14 12 13

PERFORMANCE P-Q CURVE

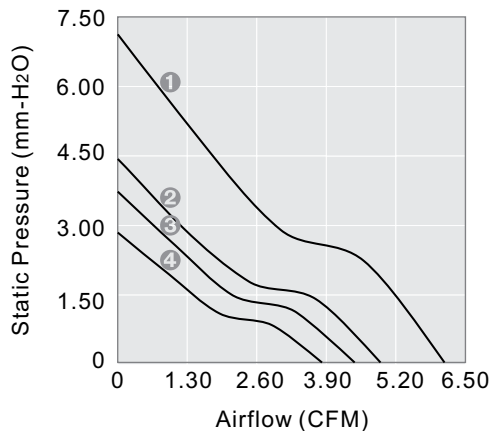

OUTLINE DIMENSIONS

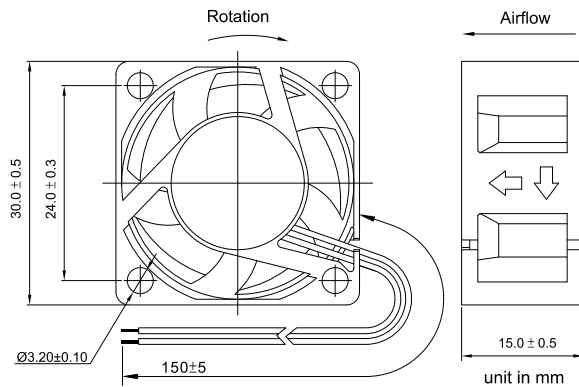

Please refer to *Model Numbering System* for bearing, function and speed level indication. Specifications are subject to changes without notice. Please refer to the formally issued product specification via contacting Y.S. TECH sales department. Visit Y.S. TECH web site at <http://www.ystechusa.com/> for updated information. Customized Specifications are designed accordingly.