



30x30x10mm

- Airflow: 2.5~4.0 CFM
- Static Pressure: 2.0~5.2 mm-H₂O
- Blade / Housing: Plastic Material UL 94V-0 P.B.T.
- Lead Wire: UL1571 #28 AWG
- Weight: 9 g

Model No.	Bearing	Rated Voltage	Operating Voltage Range	Speed	Max. Airflow	Max. Static Pressure	Current	Power Consumption	Life at 40°C L10	P-Q Curve	Noise Level
		VDC	VDC	RPM	CFM	mm-H ₂ O	mA	W	Hour		dB(A)
NYW03010005BL	2B	05	4~5.5	5800	2.5	2.0	50	0.25	80000	4	<17.0
NYW03010005BM	2B		4~5.5	6800	3.0	2.7	80	0.40	80000	3	18.0
NYW03010005BH	2B		4~5.5	7800	3.4	3.3	90	0.45	75000	2	21.5
NYW03010005BS	2B		4~5.5	10000	4.0	5.2	120	0.60	65000	1	28.0
NYW03010012BL	2B		12	9~13.2	5800	2.5	2.0	35	0.42	80000	4
NYW03010012BM	2B	7~13.2		6800	3.0	2.7	40	0.48	80000	3	18.0
NYW03010012BH	2B	7~13.2		7800	3.4	3.3	40	0.48	75000	2	21.5
NYW03010012BS	2B	7~13.2		10000	4.0	5.2	60	0.72	65000	1	28.0

Buy Now

2B: 2-ball bearing L: sintetico bearing S: sleeve bearing

Voltage Available

05 12 24 48

Bearing System Available

2B L S

Function Available

1 6 5 4 3 2 7 8 9 10 11 14 12

PERFORMANCE P-Q CURVE

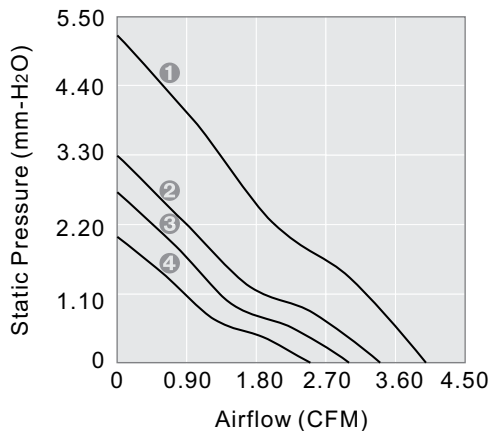

OUTLINE DIMENSIONS

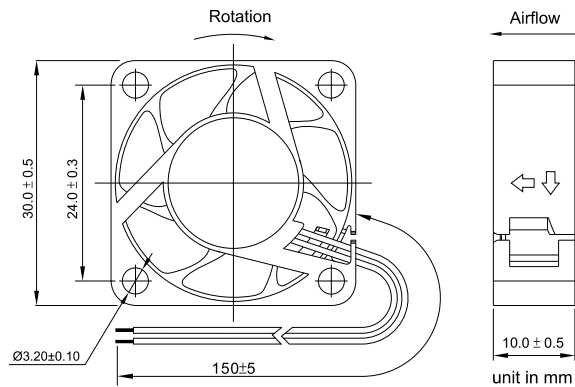

Please refer to *Model Numbering System* for bearing, function and speed level indication. Specifications are subject to changes without notice. Please refer to the formally issued product specification via contacting Y.S. TECH sales department. Visit Y.S. TECH web site at <http://www.ystechusa.com/> for updated information. Customized Specifications are designed accordingly.