



Ø 254x89mm

- Airflow: 443.0~699.8 CFM
- Static Pressure: 6.87~8.39 mm-H₂O
- Blade: Plastic Material UL 94V-0 P.B.T.
- Frame: Die-Casting Aluminum
- Weight: 2000 g

Model No.	Bearing	Rated Voltage	Freq	Speed	Max. Airflow	Max. Static Pressure	Current	Power Consumption	Life at 65°C L10	P-Q Curve	Noise Level
	VAC	Hz	RPM	CFM	mm-H ₂ O	A	W	Hour		dB(A)	
KT25489115B M 2B	115	50/60	1400/1600	443/518	6.87/8.39	0.22/0.24	34.0/37.0	40000	2/2	52.6/59.5	
KW25489115B M 2B			1400/1600	443/518	6.87/8.39	0.22/0.24	34.0/37.0	40000	2/2	52.6/59.5	
KT25489115B H 2B			2300/2200	700/620	8.90/6.80	0.55/0.62	60.0/67.0	40000	1/1	61.6/57.6	
KW25489115B H 2B			2300/2200	700/620	8.90/6.80	0.55/0.62	60.0/67.0	40000	1/1	61.6/57.6	
KT25489220B M 2B	230	50/60	1400/1600	443/518	6.87/8.39	0.16/0.14	34.0/37.0	40000	2/2	52.6/59.5	
KW25489220B M 2B			1400/1600	443/518	6.87/8.39	0.16/0.14	34.0/37.0	40000	2/2	52.6/59.5	
KT25489220B H 2B			2300/2200	700/620	8.90/6.80	0.26/0.30	60.0/67.0	40000	1/1	61.6/57.6	
KW25489220B H 2B			2300/2200	700/620	8.90/6.80	0.26/0.30	60.0/67.0	40000	1/1	61.6/57.6	

Buy Now

2B: 2-ball bearing S: sleeve bearing

Voltage Available

115 230

Bearing System Available

2B S

PERFORMANCE P-Q CURVE

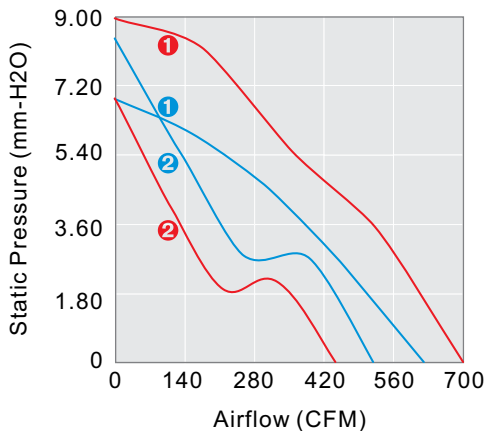

OUTLINE DIMENSIONS

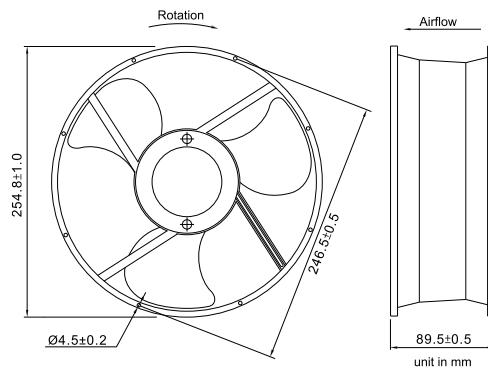

Please refer to *Model Numbering System* for bearing, function and speed level indication. Specifications are subject to changes without notice. Please refer to the formally issued product specification via contacting Y.S. TECH sales department. Visit Y.S. TECH web site at <http://www.ystechusa.com/> for updated information. Customized Specifications are designed accordingly

DC AXIAL FAN

DC BLOWER

XTREME SERIES

AC AXIAL FAN