



# 172x150x51mm

- Airflow: 190.0~223.0 CFM
- Static Pressure: 15.0~19.0 mm-H2O
- Blade: Plastic Material UL 94V-0 P.B.T.
- Frame: Die-Cast Aluminum
- Weight: 1050 g

DC AXIAL FAN

DC BLOWER

XTREME SERIES

AC AXIAL FAN

Model No.	Bearing	Rated Voltage	Freq	Speed	Max. Airflow	Max. Static Pressure	Current	Power Consumption	Life at 25°C L10	P-Q Curve	Noise Level
	VAC	Hz	RPM	CFM	mm-H <sub>2</sub> O	A	W	Hour			
KT17251115BH	2B	115	50/60	2600/3000	190/223	15.0/19.0	0.24/0.25	24.0/28.0	60000	①/②	56.6/60.6
KW17251115B H	2B		50/60	2600/3000	190/223	15.0/19.0	0.24/0.25	24.0/28.0	60000	①/②	56.6/60.6
KT17251220B H	2B	230	50/60	2600/3000	190/223	15.0/19.0	0.12/0.16	24.0/28.0	60000	①/②	56.6/60.6
KW17251220B H	2B		50/60	2600/3000	190/223	15.0/19.0	0.12/0.16	24.0/28.0	60000	①/②	56.6/60.6

Buy Now

2B: 2-ball bearing S: sleeve bearing

Voltage Available

115 230

Bearing System Available

2B S

### PERFORMANCE P-Q CURVE

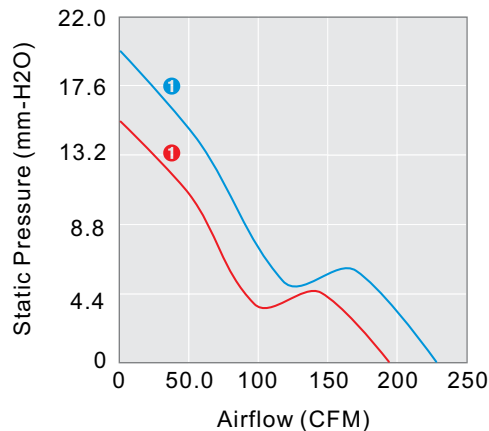

### OUTLINE DIMENSIONS

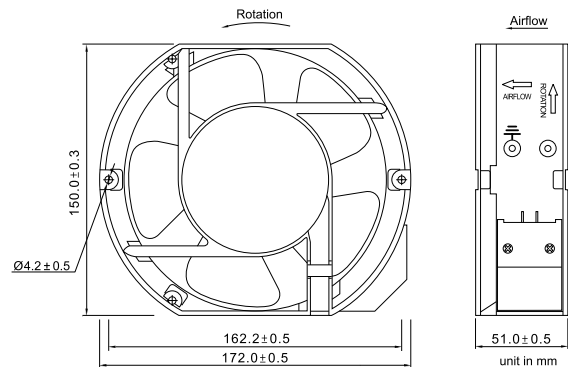

Please refer to *Model Numbering System* for bearing, function and speed level indication. Specifications are subject to changes without notice. Please refer to the formally issued product specification via contacting Y.S. TECH sales department. Visit Y.S. TECH web site at <http://www.ystechusa.com/> for updated information. Customized Specifications are designed accordingly.