



92x92x38.0mm

- Airflow: 34.0~47.0 CFM
- Static Pressure: 2.20~6.00 mm-H₂O
- Blade: Plastic Material UL 94V-0 P.B.T.
- Frame: Die-Cast Aluminum
- Weight: 450 g

Model No.	Bearing	Rated Voltage	Freq	Speed	Max. Airflow	Max. Static Pressure	Current	Power Consumption	Life at 40°C L10	P-Q Curve	Noise Level
	VAC	Hz	RPM	CFM	mm-H ₂ O	A	W	Hour		dB(A)	
KT09238115 SH	S	115	50/60	2550/3100	40/47	4.50/6.00	0.12/0.11	14.0/12.0	20000	1/1	36.0/41.0
KW09238115 SH	S	115	50/60	2550/3100	40/47	4.50/6.00	0.12/0.11	14.0/12.0	20000	1/1	36.0/41.0
KT09238115B L	2B	115	50/60	1900/1800	36/34	3.20/2.20	0.05/0.04	7.0/5.0	60000	3/3	30.2/27.8
KW09238115B L	2B	115	50/60	1900/1800	36/34	3.20/2.20	0.05/0.04	7.0/5.0	60000	3/3	30.2/27.8
KT09238115BM	2B	115	50/60	2200/2400	38/40	3.88/3.78	0.07/0.06	11.0/9.0	60000	2/2	32.9/35.3
KW09238115BM	2B	115	50/60	2200/2400	38/40	3.88/3.78	0.07/0.06	11.0/9.0	60000	2/2	22.9/35.3
KT09238115BH	2B	230	50/60	2550/3100	40/47	4.50/6.00	0.12/0.11	14.0/12.0	60000	1/1	36.0/41.0
KW09238115BH	2B	230	50/60	2550/3100	40/47	4.50/6.00	0.12/0.11	14.0/12.0	60000	1/1	36.0/41.0
KT09238220 SH	S	230	50/60	2550/3100	40/47	4.50/6.00	0.06/0.05	14.0/12.0	60000	1/1	36.0/41.0
KW09238220 SH	S	230	50/60	2550/3100	40/47	4.50/6.00	0.06/0.05	14.0/12.0	60000	1/1	36.0/41.0
KT09238220BH	2B	230	50/60	2550/3100	40/47	4.50/6.00	0.06/0.05	14.0/12.0	60000	1/1	36.0/41.0
KW09238220BH	2B	230	50/60	2550/3100	40/47	4.50/6.00	0.06/0.05	14.0/12.0	60000	1/1	36.0/41.0

Buy Now

2B: 2-ball bearing S: sleeve bearing

Voltage Available
115 230

Bearing System Available
2B S

PERFORMANCE P-Q CURVE

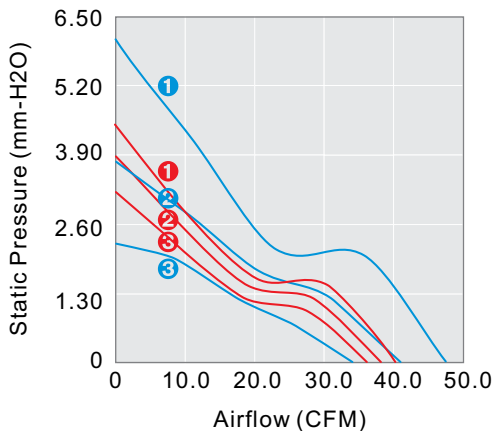

OUTLINE DIMENSIONS

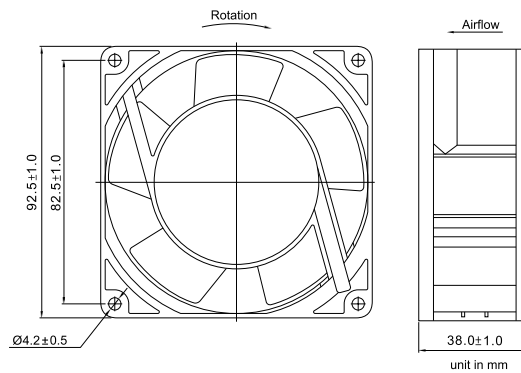

Please refer to Model Numbering System for bearing, function and speed level indication. Specifications are subject to changes without notice. Please refer to the formally issued product specification via contacting Y.S. TECH sales department. Visit Y.S. TECH web site at <http://www.ystechusa.com/> for updated information. Customized Specifications are designed accordingly.