



# 80x80x25mm

- Airflow: 14.5~18.3 CFM
- Static Pressure: 3.31~5.16 mm-H2O
- Blade: Plastic Material UL 94V-0 P.B.T.
- Frame: Die-Cast Aluminum
- Weight: 260 g

DC AXIAL FAN

DC BLOWER

XTREME SERIES

AC AXIAL FAN

| Model No.        | Bearing | Rated Voltage | Freq      | Speed     | Max. Airflow        | Max. Static Pressure | Current   | Power Consumption | Life at 40°C L10 | P-Q Curve | Noise Level |
|------------------|---------|---------------|-----------|-----------|---------------------|----------------------|-----------|-------------------|------------------|-----------|-------------|
|                  | VAC     | Hz            | RPM       | CFM       | mm-H <sub>2</sub> O | A                    | W         | Hour              |                  |           |             |
| KT08025115S H S  | 115     | 50/60         | 2500/3000 | 14.5/18.3 | 3.31/5.16           | 0.17/0.15            | 15.0/13.0 | 20000             | 1/1              | 28.2/35.0 |             |
| KW08025115S H S  |         |               |           | 14.5/18.3 | 3.31/5.16           | 0.17/0.15            | 15.0/13.0 | 20000             | 1/1              | 28.2/35.0 |             |
| KT08025115B H 2B |         |               |           | 14.5/18.3 | 3.31/5.16           | 0.17/0.15            | 15.0/13.0 | 60000             | 1/1              | 28.2/35.0 |             |
| KW08025115B H 2B |         |               |           | 14.5/18.3 | 3.31/5.16           | 0.17/0.15            | 15.0/13.0 | 60000             | 1/1              | 28.2/35.0 |             |
| KT08025220S H S  | 230     | 50/60         | 2500/3000 | 14.5/18.3 | 3.31/5.16           | 0.08/0.07            | 15.0/13.0 | 20000             | 1/1              | 28.2/35.0 |             |
| KW08025220S H S  |         |               |           | 14.5/18.3 | 3.31/5.16           | 0.08/0.07            | 15.0/13.0 | 20000             | 1/1              | 28.2/35.0 |             |
| KT08025220B H 2B |         |               |           | 14.5/18.3 | 3.31/5.16           | 0.08/0.07            | 15.0/13.0 | 60000             | 1/1              | 28.2/35.0 |             |
| KW08025220B H 2B |         |               |           | 14.5/18.3 | 3.31/5.16           | 0.08/0.07            | 15.0/13.0 | 60000             | 1/1              | 28.2/35.0 |             |

Buy Now

2B: 2-ball bearing S: sleeve bearing

Voltage Available

115 230

Bearing System Available

2B S

### PERFORMANCE P-Q CURVE

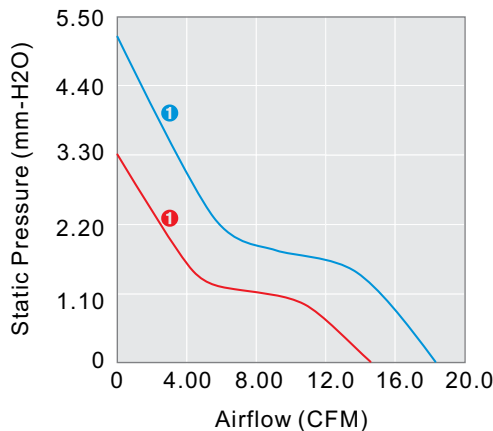

### OUTLINE DIMENSIONS

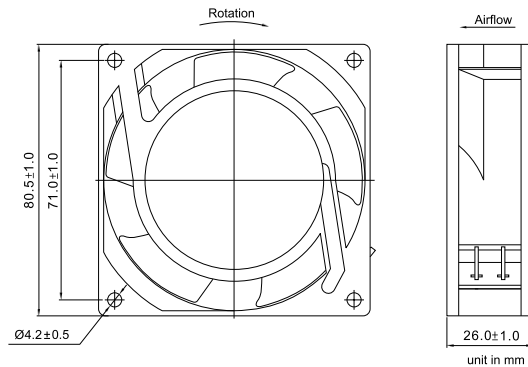

Please refer to *Model Numbering System* for bearing, function and speed level indication. Specifications are subject to changes without notice. Please refer to the formally issued product specification via contacting Y.S. TECH sales department. Visit Y.S. TECH web site at <http://www.ystechusa.com/> for updated information. Customized Specifications are designed accordingly.