

## DP86 Constant Voltage with Fitting



- 316L SS
- Wet/Wet Differential
- Low Pressure
- 0 – 100mV Output



### DESCRIPTION

The DP86 constant voltage with fitting differential pressure sensor is a double-sided, media compatible, piezoresistive silicon pressure sensor packaged in a 316L stainless steel housing. The DP86 constant voltage with fitting can be designed with up to 8 different threaded process fittings. The sensing package utilizes silicone oil to transfer pressure from the two 316L stainless steel diaphragms to a single sensing element.

The DP86 constant voltage with fitting is designed for high performance, low pressure applications where differential pressure measurement is required. The stainless steel package makes it suitable for use in liquids and corrosive environments.

Please refer to the DP86, uncompensated, non-silicone oil, constant current and constant voltage (fittings and cable design) for more information on different features of the DP86.

### FEATURES

- Threaded Process Fittings
- Up to -40°C to +125°C Operating Range
- Up to ±0.1% Pressure Non Linearity
- Solid State Reliability
- Low Pressure

### APPLICATIONS

- Level Controls
- Tank Level Measurement
- OEM Equipment
- Corrosive Fluids and Gas Measurement Systems
- Flow Measurements

### STANDARD RANGES

Range	psid	Range	bard
0 to 1	•	0 to .07	•
0 to 5	•	0 to .35	•
0 to 15	•	0 to 001	•
0 to 30	•	0 to 002	•
0 to 50	•	0 to 3.5	•
0 to 100	•	0 to 007	•
0 to 300	•	0 to 020	•
0 to 500	•	0 to 035	•

# DP86 Constant Voltage with Fitting

## PERFORMANCE SPECIFICATIONS

Supply Voltage: 10Vdc

Ambient Temperature: 25°C (unless otherwise specified)

PARAMETERS	≤005PSI			≥015PSI			UNITS	NOTES
	MIN	TYP	MAX	MIN	TYP	MAX		
Span		1psi: 77, 80, 83 5psi: 98, 100, 102		99	100	101	mV	
Zero Pressure Output	-2.0	0	2.0	-1.0	0	1.0	mV	1
Pressure Non Linearity		1psi: -0.30 to 0.30 5psi: -0.20 to 0.20		-0.10		0.10	%Span	2
Pressure Hysteresis	-0.10	±0.02	0.10	-0.05	±0.02	0.05	%Span	
Repeatability		±0.02			±0.02		%Span	
Accuracy RMS of NL, HY, RP		±0.6	±1.0		±0.6	±1.0	%Span	
Input Resistance	5500	9000	12500	5500	9000	12500	Ω	
Output Resistance	4000		30000	4000		25000	Ω	
Temperature Error – Span	-1.5		1.5	-1.0		1.0	%Span	3
Temperature Error – Offset	-2.5		2.5	-1.0		1.0	%Span	4
Thermal Hysteresis – Span	-0.25	±0.05	0.25	-0.25	±0.05	0.25	%Span	3
Thermal Hysteresis – Offset	-0.25	±0.05	0.25	-0.25	±0.05	0.25	%Span	3
Long Term Stability – Span		±0.10			±0.10		%Span/Year	
Long Term Stability – Offset		±0.25			±0.10		%Span/Year	
Line (Common Mode) Pressure			1000			1000	psi	
Line Pressure Effect on Zero		1psi: 4.0 Max 5psi: 0.8 Max				0.5	%Span/1Kpsi	
Supply Voltage		10	14		10	14	V	4
Output Load Resistance	5			5			MΩ	5
Insulation Resistance (50Vdc)	50			50			MΩ	6
Output Noise (10Hz to 1KHz)		1.0			1.0		uV p-p	
Response Time (10% to 90%)		0.1			0.1		ms	
Pressure Overload		1psi: 10X Max 5psi: 3X Max				3X	Rated	7
Pressure Burst		1psi: 12X Max 5psi: 4X Max				4X	Rated	7
Compensated Temperature		1psi: 0°C to 50°C 5psi: 0°C to 70°C		-20		+85	°C	
Operating Temperature		1psi: -40°C to +85°C 5psi: -40°C to +125°C		-40		+125	°C	8
Storage Temperature	-40		+125	-40		+125	°C	8
Voltage Breakdown	500V rms @ 50Hz, Leakage Current < 1mA							
Shock	50g, 1msec half sine shock per MIL-STD-202G, Method 213B, Condition A							
Vibration	±20g MIL-STD 810C, Procedure 514.2, Figure 514.2-2, Curve L							
Media – Pressure Port	Liquids and gases compatible with 316/316L Stainless Steel							

### Notes

1. Measured at ambient.
2. Best fit straight line
3. Over the compensated temperature range with respect to 25°C.
4. Guarantees output/input ratiometricity.
5. Load resistance to reduce measurement errors due to output loading.
6. Between case and sensing element.
7. For "H" (high-end) port, rated or 1000psi whichever is less. For "L" (low-end) port rated or 150psi whichever is less. The maximum pressure that can be applied to a transducer without rupture of either the sensing element or transducer.
8. -40°C to +125°C for 5psi. Maximum temperature for product with standard cable and connector is -20°C to +105°C.

# DP86 Constant Voltage with Fitting

## DIMENSIONS

Dimensions are in inches [mm]

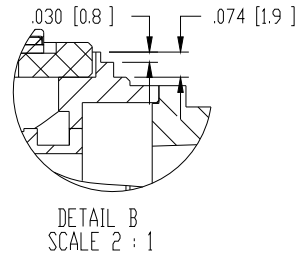
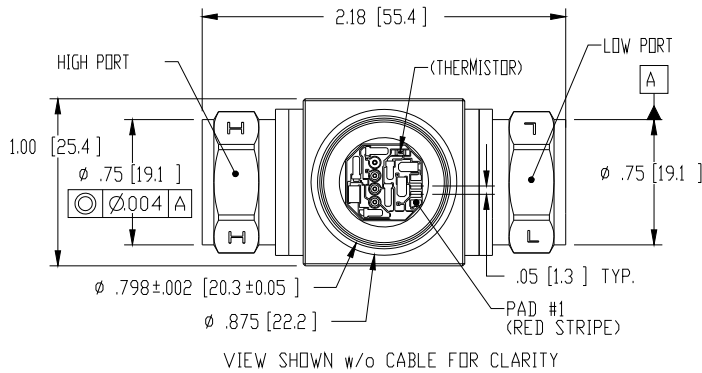

PAD NO	FUNCTION
1	-OUT
2	+OUT
3	-EX
4	+EX

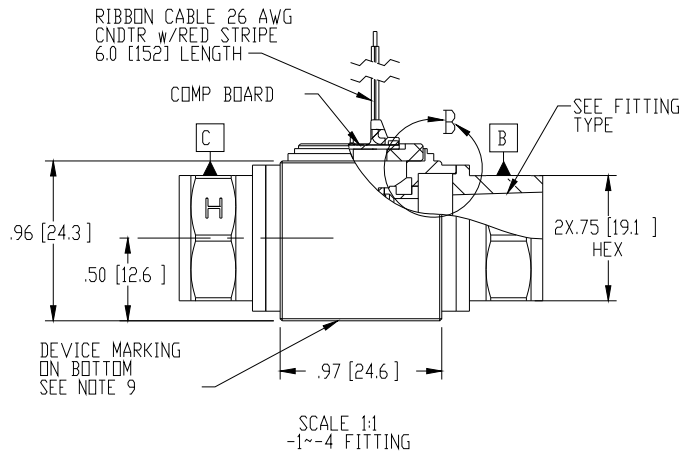

FITTING TYPE	
1	1/8-27 NPT, FEMALE, 3/4 HEX
2	1/4-18 NPT, FEMALE, 3/4 HEX
3	7/16-20 UNF, FEMALE, 3/4 HEX
4	1/4-19 BSP, FEMALE, 3/4 HEX
5	1/8-27 NPT, MALE, 3/4 HEX
6	1/4-18 NPT, MALE, 3/4 HEX
7	7/16-20 UNF, MALE, 3/4 HEX
8	1/4-19 BSP, MALE, 3/4 HEX

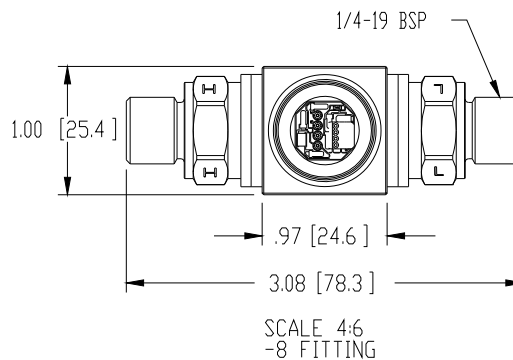
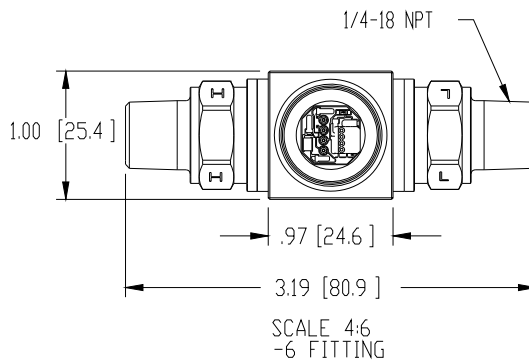
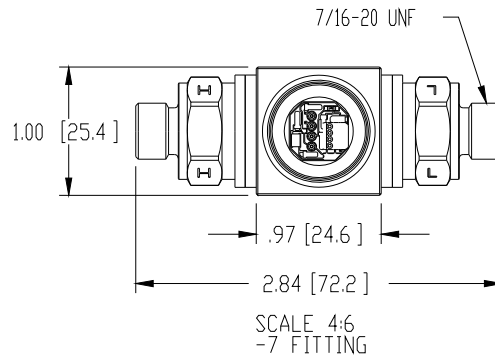
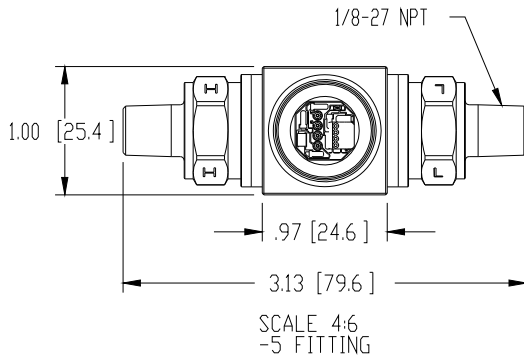

# DP86 Constant Voltage with Fitting

## CONNECTIONS

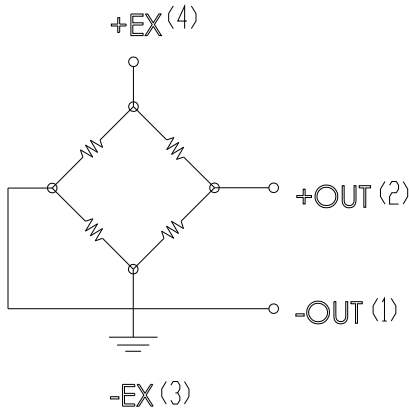

## ORDERING INFORMATION

DP86 - 015P - 1 V R

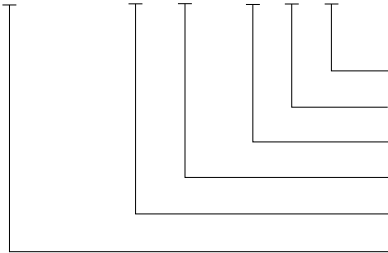

Electrical (C = Ribbon Cable with Connector, R = Ribbon Cable)  
 Type (V = Constant Voltage, Compensated)  
 Fitting (See Fitting Table)  
 Unit (P = psi, B = Bar)  
 Pressure Range  
 Model

### NORTH AMERICA

Measurement Specialties  
 45738 Northport Loop West  
 Fremont, CA 94538  
 Tel: 1-800-767-1888  
 Fax: 1-510-498-1578  
 Sales: [pfg.cs.amer@meas-spec.com](mailto:pfg.cs.amer@meas-spec.com)

### EUROPE

Measurement Specialties  
 (Europe), Ltd.  
 26 Rue des Dames  
 78340 Les Clayes-sous-Bois, France  
 Tel: +33 (0) 130 79 33 00  
 Fax: +33 (0) 134 81 03 59  
 Sales: [pfg.cs.emea@meas-spec.com](mailto:pfg.cs.emea@meas-spec.com)

### ASIA

Measurement Specialties  
 (China), Ltd.  
 No. 26 Langshan Road  
 Shenzhen High-Tech Park (North)  
 Nanshan District, Shenzhen 518057  
 China  
 Tel: +86 755 3330 5088  
 Fax: +86 755 3330 5099  
 Sales: [pfg.cs.asia@meas-spec.com](mailto:pfg.cs.asia@meas-spec.com)

The information in this sheet has been carefully reviewed and is believed to be accurate; however, no responsibility is assumed for inaccuracies. Furthermore, this information does not convey to the purchaser of such devices any license under the patent rights to the manufacturer. Measurement Specialties, Inc. reserves the right to make changes without further notice to any product herein. Measurement Specialties, Inc. makes no warranty, representation or guarantee regarding the suitability of its product for any particular purpose, nor does Measurement Specialties, Inc. assume any liability arising out of the application or use of any product or circuit and specifically disclaims any and all liability, including without limitation consequential or incidental damages. Typical parameters can and do vary in different applications. All operating parameters must be validated for each customer application by customer's technical experts. Measurement Specialties, Inc. does not convey any license under its patent rights nor the rights of others.