

Model 8042-VR/-VP Submersible Velocity Transmitter

4-20mA Loop Power Transmitter
True RMS or Peak Output
IP68 Protection, >100meters
Integral Cable, Tefzel & Urethane



The Model 8042-VR/VP is a submersible velocity transmitter designed for harsh environments. The transmitter is available in ranges from 0.5 to 5.0 in/sec, in either 4-20mA RMS or Peak velocity output options, and features a welded Titanium housing. The model 8042 features an integral cable that is custom designed for submersible applications and features a unique water block feature that self-seals in the event of accidental cuts to the cable. The accelerometer includes internal shielding and a usable bandwidth to 1000Hz.

FEATURES

- 0.5 to 5.0 in/sec Dynamic Range
- 3-1000Hz Bandwidth
- Case Isolated, Internally Shielded
- Welded Titanium
- Annular Shear Mode Crystals
- Reverse Wiring Protection

APPLICATIONS

- Submersible Pumps
- Rotating Machinery Monitoring
- Underwater Vibration Monitoring
- Outdoor, Harsh Environments
- Gearbox Monitoring
- Shipboard Installations

dimensions

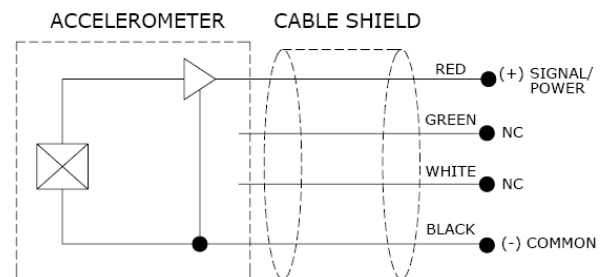
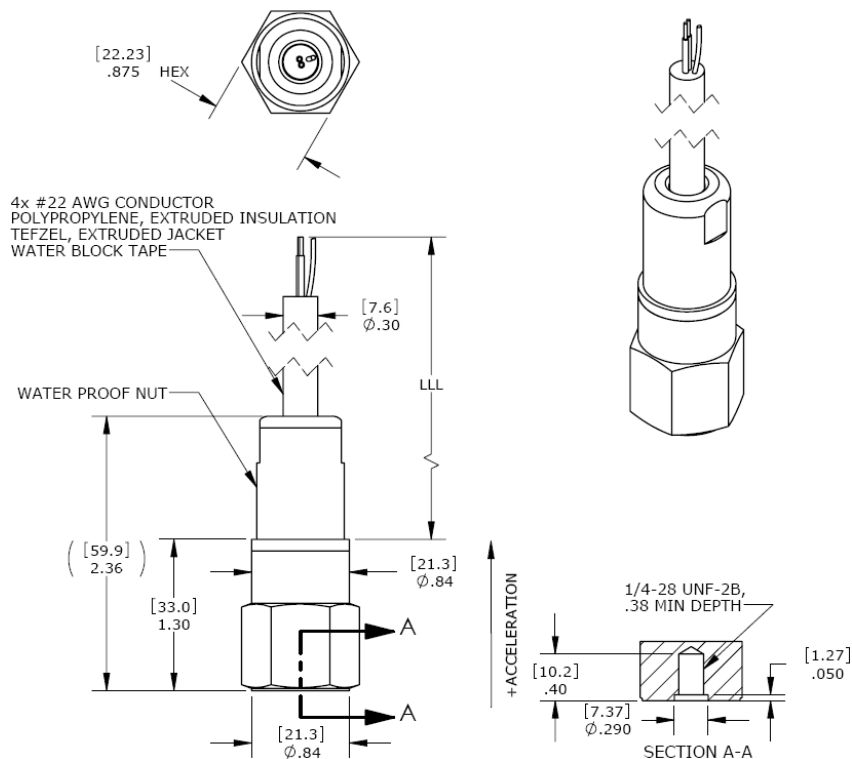

Model 8042-VR/-VP Submersible Velocity Transmitter

performance specifications

All values are typical at +24°C, 100Hz and 15Vdc excitation unless otherwise stated. Measurement Specialties reserves the right to update and change these specifications without notice. Standard product parameters are described in PSC-1003 for Plug & Play AC Accelerometers. Measurement Specialties family of [Piezoelectric Accelerometers](#) are used for vibration/shock monitoring, structural analysis, impact detection and machine monitoring.

Parameters

						Notes
DYNAMIC						
Measurement Range (in/sec)	0-0.5	0-1.00	0-2.00	0-3.00	0-5.00	
Measurement Range (mm/sec)	0-12.7	0-25.4	0-50.8	0-76.2	0-127	
Output (mA)	4-20	4-20	4-20	4-20	4-20	See Note 1
Frequency Response (cpm)	180-60000	180-60000	180-60000	180-60000	180-60000	±10%
Frequency Response (Hz)	3-1000	3-1000	3-1000	3-1000	3-1000	±10%
Non-Linearity (%FSO)	±1					
Transverse Sensitivity (%)	<5					
Shock Limit (g)	5000					

ELECTRICAL

Excitation Voltage (Vdc)	12 to 30					
Loop Resistance (Ohms)	900 max					See Note 2
Turn on Time (sec)	<15					
Grounding	Case Isolated, Internally Shielded					

ENVIRONMENTAL

Temperature Response (%)	±5					
Operating Temperature (°C)	-20 to +80 for T (Tefzel) option cable					
	-20 to +60 for U (Urethane) option cable					
Protection Rating	IP68, 100meter minimum submersion					

PHYSICAL

Sensing Element	Ceramic (shear mode)
Case Material	Titanium
Weight (grams)	70
Mounting Torque	24 lb-in (2.7 N-m)

Calibration supplied: CS-FREQ-0100 NIST Traceable Amplitude Calibration from 20Hz to ±10% Frequency Response Limit

Supplied accessories: AC-A03663 ¼-28 to ¼-28 mounting stud

Optional accessories: AC-D03664 ¼-28 to M5 mounting stud
 AC-D03665 ¼-28 to M6 mounting stud
 AC-A04209 Magnetic Mounting Adaptor
 AC-D04210 Adhesive Mounting Adaptor

Note 1

The signal output from the 8042 sensor can be calculated using the following formulas.

$$\text{Velocity Level in IPS (in/sec)} = (\text{Signal Output in mA} - 4\text{mA}) \times (\text{Full Scale Range in IPS} / 16\text{mA})$$

Typical outputs are illustrated in the tables below.

Signal Output	8042-VR & 8042-VP Velocity Transmitter Ranges				
	0.50in/sec	1.00in/sec	2.00in/sec	3.00in/sec	5.00in/sec
4mA	0.00in/sec	0.00in/sec	0.00in/sec	0.00in/sec	0.00in/sec
8mA	0.125in/sec	0.25in/sec	0.50in/sec	0.75in/sec	1.25in/sec
12mA	0.25in/sec	0.50in/sec	1.00in/sec	1.50in/sec	2.50in/sec
16mA	0.375in/sec	0.75in/sec	1.50in/sec	2.25in/sec	3.75in/sec
20mA	0.50in/sec	1.00in/sec	2.00in/sec	3.00in/sec	5.00in/sec

Note 2

Maximum Loop Resistance = (Excitation Voltage – 12Vdc) / 20mA

Model 8042-VR/-VP Submersible Velocity Transmitter

ordering info

PART NUMBERING Model Number+Output Type+Range+Cable Option+Cable Length

8042-XX-GG-TZZZZ

| | | | Cable Length (0360 is 360 inches)

| | | Cable Jacket Option (T is Tefzel, U is Urethane)

| | Dynamic Range (05 is 0-0.5 in/sec)

| Range Type (VR is RMS Velocity)

-XX

VR = RMS

VP = Peak

-GG

05 = 0-0.5 in/sec (0-12.7 mm/sec)

10 = 0-1.0 in/sec (0-25.4 mm/sec)

20 = 0-2.0 in/sec (0-50.8 mm/sec)

30 = 0-3.0 in/sec (0-76.2 mm/sec)

50 = 0-5.0 in/sec (0-127 mm/sec)

Example: 8042-VR-10-U0360

Model 8042, RMS Velocity Output, 0-1.0 in/sec, Urethane Cable, 360 inch (30ft) Cable Length

contact info

NORTH AMERICA

Measurement Specialties, Inc.

1000 Lucas Way
Hampton, VA 23666
USA

Tel: +1-800-745-8008 or

+1-757-766-1500

Fax: +1-757-766-4297

Sales: pvg.cs.amer@meas-spec.com

EUROPE

Measurement Specialties (Europe), Ltd.

26 Rue des Dames
F78340 Les Clayes-sous-Bois
France

Tel: +33 (0) 130 79 33 00

Fax: +33(0) 134 81 03 59

Sales: pfg.cs.emea@meas-spec.com

ASIA

Measurement Specialties (China), Ltd.

No. 26 Langshan Road
Shenzhen High-Tech Park (North)
Nanshan District, Shenzhen 518057
China

Tel: +86 755 3330 5088

Fax: +86 755 3330 5099

Sales: pfg.cs.asia@meas-spec.com

The information in this sheet has been carefully reviewed and is believed to be accurate; however, no responsibility is assumed for inaccuracies. Furthermore, this information does not convey to the purchaser of such devices any license under the patent rights to the manufacturer. Measurement Specialties, Inc. reserves the right to make changes without further notice to any product herein. Measurement Specialties, Inc. makes no warranty, representation or guarantee regarding the suitability of its product for any particular purpose, nor does Measurement Specialties, Inc. assume any liability arising out of the application or use of any product or circuit and specifically disclaims any and all liability, including without limitation consequential or incidental damages. Typical parameters can and do vary in different applications. All operating parameters must be validated for each customer application by customer's technical experts. Measurement Specialties, Inc. does not convey any license under its patent rights nor the rights of others.