

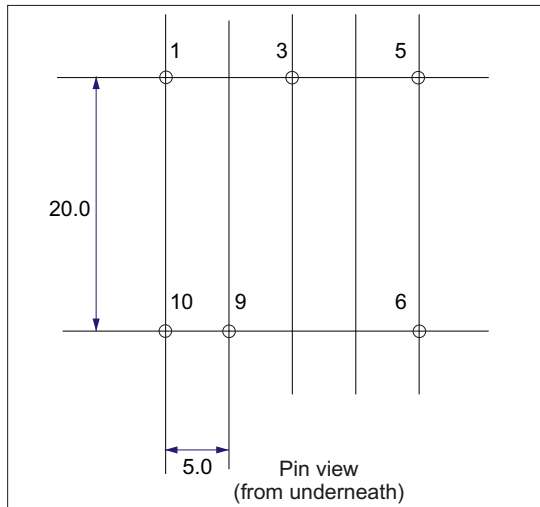

Label
YYWW = date code

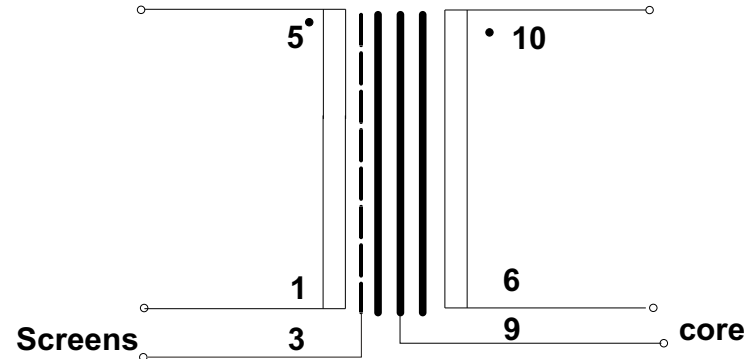
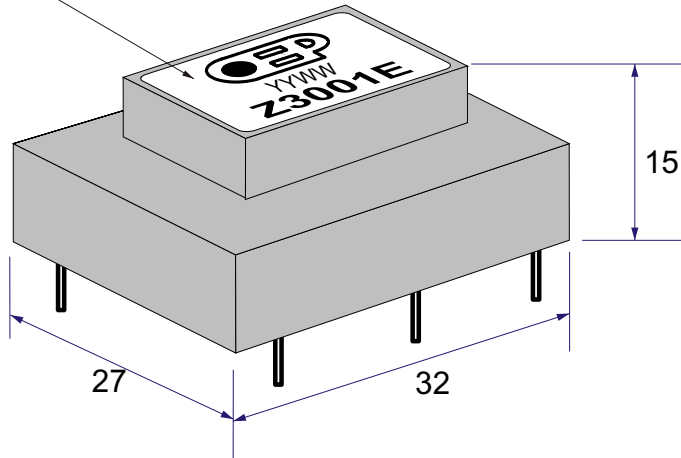

Mass = 0.045kg
Pin diameter = 0.80mm

Electrical specification:

Ratio: 1 to 1
Source impedance: 600 ohms
Optimum load impedance: 600 ohms
Frequency range: 20Hz - 20kHz, +/- 0.2dB
THD: < 1% at + 20dB
Common mode rejection ratio: < -60dB @ 10kHz
Primary DC resistance: 30 ohms +/- 15%
Secondary DC resistance: 30 ohms +/- 15%
Nominal inductance: 390mH @ 100Hz, 0.27V

Operating temperature range: -20°C to + 70°C
Fitted with electrostatic screen and stray flux screen.

Optional mu-metal screening can is available (33 x 28 x 16mm) to reduce electrical hum by up to 30dB

10k ohm impedance version available, part number Z3002E

Walters Group Holdings Ltd.
Unit 5, Oxonian Park, Langford Locks,
Kidlington, Oxfordshire. OX5 1FP
Tel: (01865) 855085 Fax: (01865) 855075
Website: www.oep.co.uk

DESCRIPTION	ISSUE	DATE	DRAWN	CHECKED	DRAWING NUMBER
Specification for Z3001E	1	01/07/04	CS		Z3001E
	3	19/07/05	CS		
	4	07/06/10	CS		
	5	29/04/13	CS		
	Scale: nts	All dimensions in mm unless stated otherwise			