

Ethernet OptoLock® Evaluation Kit

EVAL-EDL301T

EVALUATION KIT



Ethernet OptoLock® Evaluation Kit User Guide

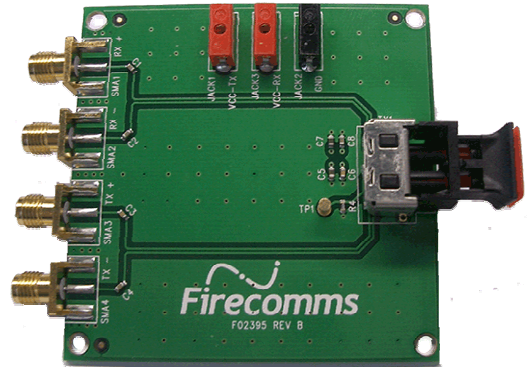

OVERVIEW

The EVAL-EDL301T Evaluation Kit enables evaluation of the Firecomms OptoLock® connector for bare plastic optic fiber (POF) termination. The kit includes a single piece of the OptoLock connector pre-mounted onto a simple PCB that allows easy application of DC power via standard 2 mm diameter DC jacks. Data input (TX) and data output (RX) are via standard screw terminal SMA connectors.

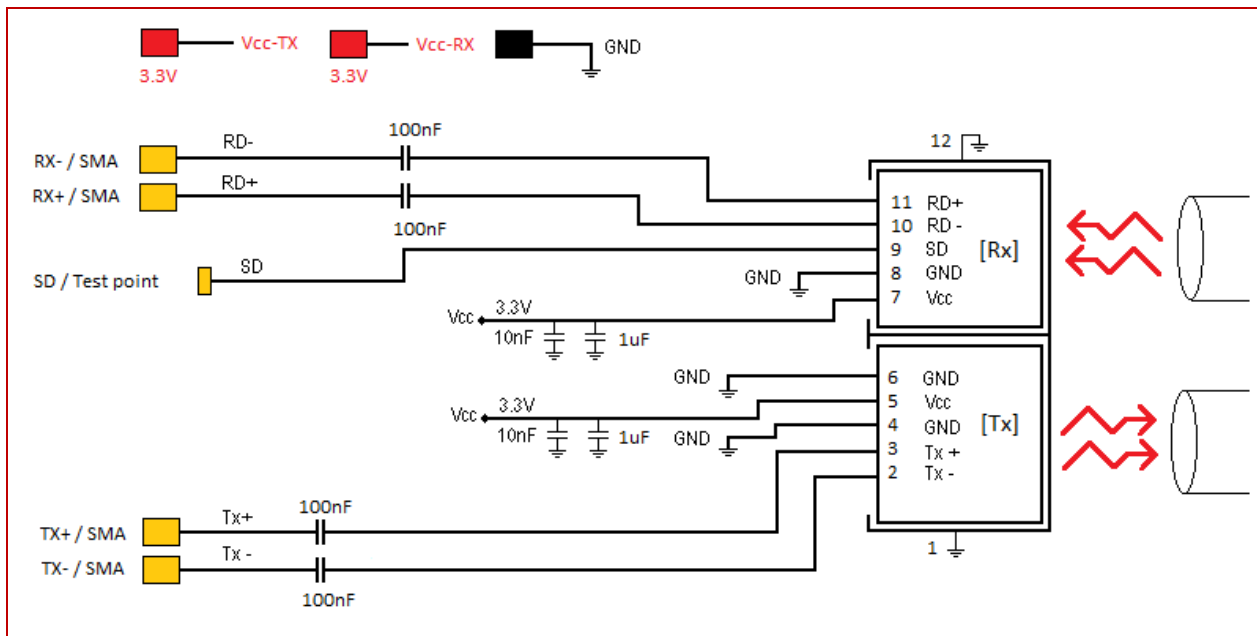

FIGURE 1
Layout of the OptoLock Evaluation PCB.

EVALUATION KIT CONTENTS

The Evaluation Kit contains the following:

1. Evaluation PCB
2. EDL301T mounted onto the test PCB
3. POF cable (1 m, 0.5 NA, 2.2 mm jacket duplex POF)
4. Data sheet

INITIAL SETUP

1. Connect GND of a DC power supply to the ground point of the PCB (black terminal).
2. Connect 3.3V to each of the TX and RX VCC jacks (red terminals).
3. Connect an oscilloscope probe (1M Ω) to the Signal Detect (SD) test point.
4. Connect a suitable pattern generator differential data signals via SMA cables to the TX +/- data pins.
5. Connect the RX +/- data pins to a suitable high speed oscilloscope using 50 Ω termination and high-speed coax, SMA terminated cables.
6. For a loop-back cable test, insert the POF cable into the TX and then loop it back to the RX side of the OptoLock connector. Push in the OptoLock clamp to lock it home.

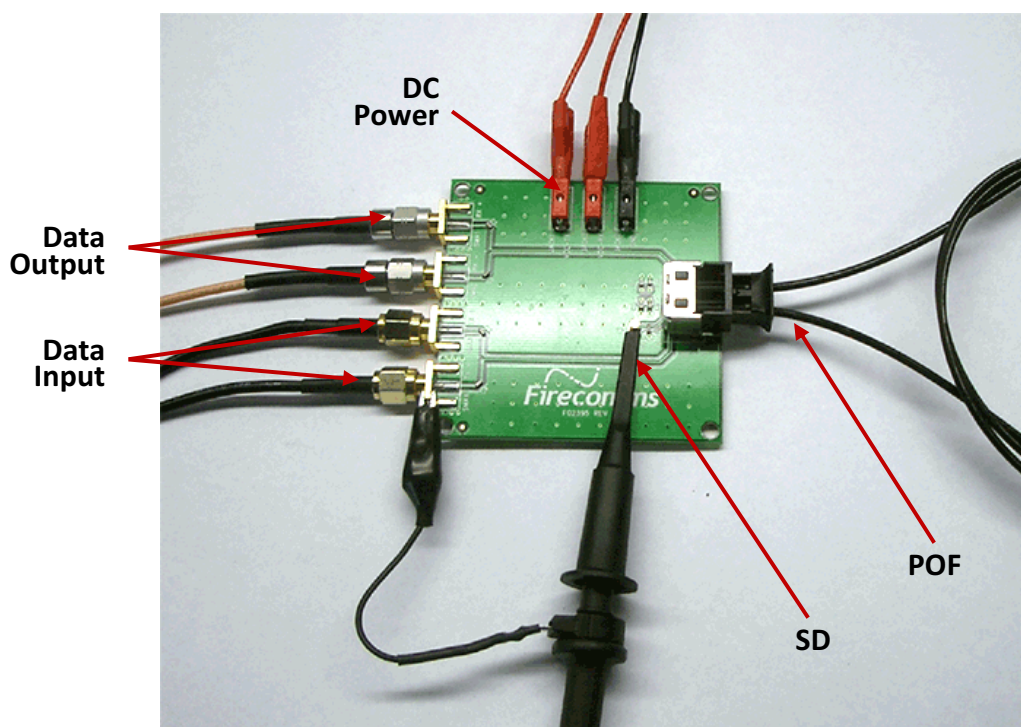

FIGURE 2
Setup of the Evaluation PCB.