

Ethernet OptoLock®

EDL301T

DATA SHEET



650 nm 100 Mbps Fiber Optic Transceiver for Ethernet over Bare POF with LVPECL Output Differential Swing

*Direct Compatibility with All
Ethernet PHY ICs Supporting IEEE
802.3 100Base-FX*



FEATURES

- Simple low-cost termination solution for bare POF
- Suitable for standard 2.2mm POF
- LVPECL output data bus (800-1400) mV
- Visible red light from eye-safe RCLED
- Includes CMOS LED driver (TX)
- High-sensitivity CMOS receiver and silicon Photo-Diode (PD)
- Integrated optics to efficiently focus and direct light to a 1mm fiber core with 0.5/.03 NA
- Compatible with IEEE 802.3u Fast Ethernet data communications standard
- Seamless digital to light/light to digital conversion
- RoHS compliant
- MTTF over 4×10^6 hours (60% CL @ 40°C)

DESCRIPTION

Firecomms Ethernet transceiver combines both transmitter and receiver fiber optic components in a small form factor housing. OptoLock® allows bare fiber termination of standard jacketed Plastic Optic Fiber (POF) with a simple insert and lock system. It is an ideal solution for Fast Ethernet telecoms-installed IPTV and self-installed home networking.

The EDL301T-xxx, delivers bandwidth of 100 Mb over POF in a point-to-point LAN. It has a very simple AC-coupled interface to any Ethernet PHY IC supporting IEEE 802.3 100Base-FX.



*POF-enabled set top
box with OptoLock*

Without the need for special tooling or expensive splicing equipment, the OptoLock design enables the fiber to be cut to length on-site with minimum of waste, and terminated quickly and reliably without the need for expensive equipment or specially trained staff.

The transmitter is a high speed RCLED (Resonant Cavity LED) driven by a CMOS IC. The receiver combines a photo-diode, trans-impedance amplifier and limiting amplifier, providing a digital output on an LVPECL type data bus compatible with all Ethernet PHY ICs.

OptoLock is protected by U.S. patents 7,597,485 and 7,905,665, Chinese patents 101501545 A and 102135650 B and other international patents.

EDL301T-xxx Revision B

Firecomms assumes no responsibility for inaccuracies or omissions in the information contained in this document. Specifications are subject to change without notice. No patent rights are granted to any of the circuits described herein.

TERMINATION STEPS

A POF link is quickly set up by cutting the duplex fiber with a sharp-blade, pulling open the clamp on the front of OptoLock, inserting both sides (the lit fiber to the unlit side of the connector), pushing the fiber into OptoLock until you meet resistance, and locking it in place with the clamp. These steps are shown here:



FIGURE 1
Cut the POF from its reel.

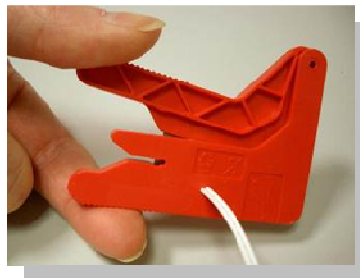

FIGURE 2
Cut a clean finish to the end.



FIGURE 3
Split the duplex POF.

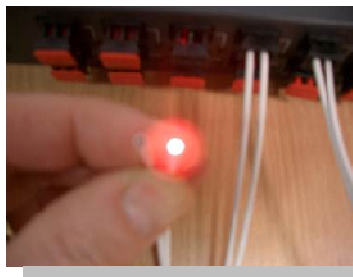

FIGURE 4
Identify the POF core with light.

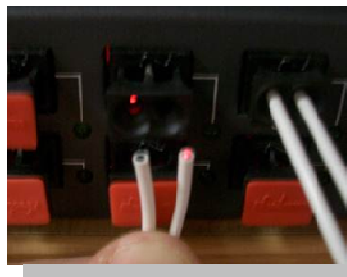

FIGURE 5
Present the lit POF core to the dark side of OptoLock.

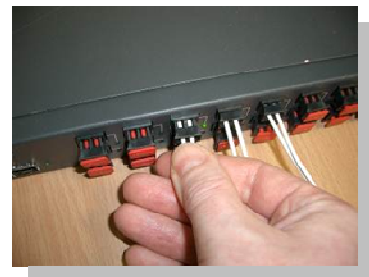

FIGURE 6
Insert and slide POF until it stops.

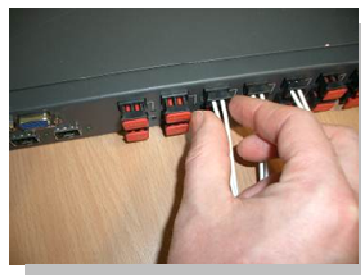

FIGURE 7
Push in the front clamp to lock POF into place.

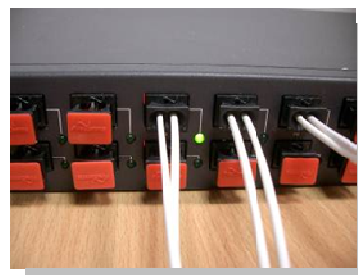

FIGURE 8
If the link is fully connected, the indicator LED flashes to show activity on the Ethernet link.

SPECIFICATIONS

ABSOLUTE MAXIMUM RATINGS				
<i>These are the absolute maximum ratings at or beyond which the FOT can be expected to be damaged.</i>				
Parameter	Symbol	Minimum	Maximum	Unit
Storage Temperature	T_{stg}	-20	+85	°C
Operating Temperature	T_{op}	-20	+70	°C
Soldering Temperature ^[1]			+260	°C
Supply Voltage	V_{CC}	-0.5	+4.5	V
Receiver Optical Power Overload	P_{OL}		0	dBm
Storage Compliance	MSL		2a	J-STD-020D

Notes:

1. 260°C, 5s 3 times, at least 2.2mm away from lead root.

TRANSMITTER ELECTRICAL AND OPTICAL CHARACTERISTICS					
Parameter	Symbol	Minimum	Typical	Maximum	Unit
Supply Voltage	V_{CC}	3.00	3.30	3.60	V
Current Consumption	I_{CC}	30.0	37.0	52.0	mA
Data Rate		10	125		Mbps
Input Capacitance	C_{in}			5.00	pF
Input Resistance	R_{in}		5.00		kΩ
Input Common-Mode Voltage Range	V_{IB}	GND+0.8		$V_{CC}-0.8$	V
Differential Input Voltage Swing	V_{ID}	100		1200	mV
Optical Power OFF Delay	T_{PD}	0.02		20.00	μs
Optical Power ON Delay	T_{PU}			5.00	μs
Peak Wavelength	λ_{peak}	640	660	670	nm
Spectral Bandwidth (FWHM)	$\Delta\lambda$	18	24	27	nm
Average Output Power	P_{50}	-8.5	-5.5	-1.5	dBm
Optical Rise Time (20%-80%)	T_R	0.50	1.30	2.50	ns
Optical Fall Time (80%-20%)	T_F	0.40	0.50	0.60	ns
Optical Modulation Amplitude	OMA	160	590	1250	μW
Open Eye Width	T_{eye}	6.5	7.4	7.9	ns

EDL301T-xxx Revision B

Firecomms assumes no responsibility for inaccuracies or omissions in the information contained in this document. Specifications are subject to change without notice. No patent rights are granted to any of the circuits described herein.



SPECIFICATIONS (continued)

RECEIVER ELECTRICAL AND OPTICAL CHARACTERISTICS					
Parameter	Symbol	Minimum	Typical	Maximum	Unit
Supply Voltage	V_{CC}	3.0	3.3	3.6	V
Current Consumption	I_{CC}	35	43	50	mA
Data Rate ^[4]		10	125		Mbps
Output Differential Impedance	R_{DIFF}		100		Ω
Output Common-Mode Voltage	V_{OB}		1.2		V
Output Differential Voltage Swing	V_{OD}	800	1150	1400	mV
Optical Rise Time (10% - 90%)	T_R	2	1.6	3	ns
Optical Fall Time (90% - 10%)	T_F	2	1.6	3	ns
Average Input Sensitivity	P_{in}			-24	dBm
Optical Overload				0	dBm
Signal Detect Assert/Deassert Time	T_{SD}	0.1	0.25	0.6	μ s
Signal Detect Optical Assert Level	p_{SD-AS}	-32.0	-27.5	-24.0	dBm
Signal Detect Optical Deassert Level	P_{SD-DAS}	-32.0	-28.5	-25.0	dBm
Signal Detect Voltage High ^[6] ($V_{OH} - V_{CC}$)	V_{SDH}	2.4	3.0	3.6	V
Signal Detect Voltage Low ^[6] ($V_{OL} - V_{CC}$)	V_{SDL}	0.0	0.05	0.10	V
Open Eye Width	EW	6.5	7.4	7.9	ns

Notes:

2. All tests were performed using an OptoLock connector for 2.2mm jacket coupled to 1mm core 0.5NA POF.
3. Test data was obtained at the upper data rate limit of 125 Mbps using a PRBS7 test pattern.
4. Test data was validated at 125 Mbps over the temperature range -20°C to +70°C and over the supply voltage range 2.97V to 3.63V.

MECHANICAL INFORMATION

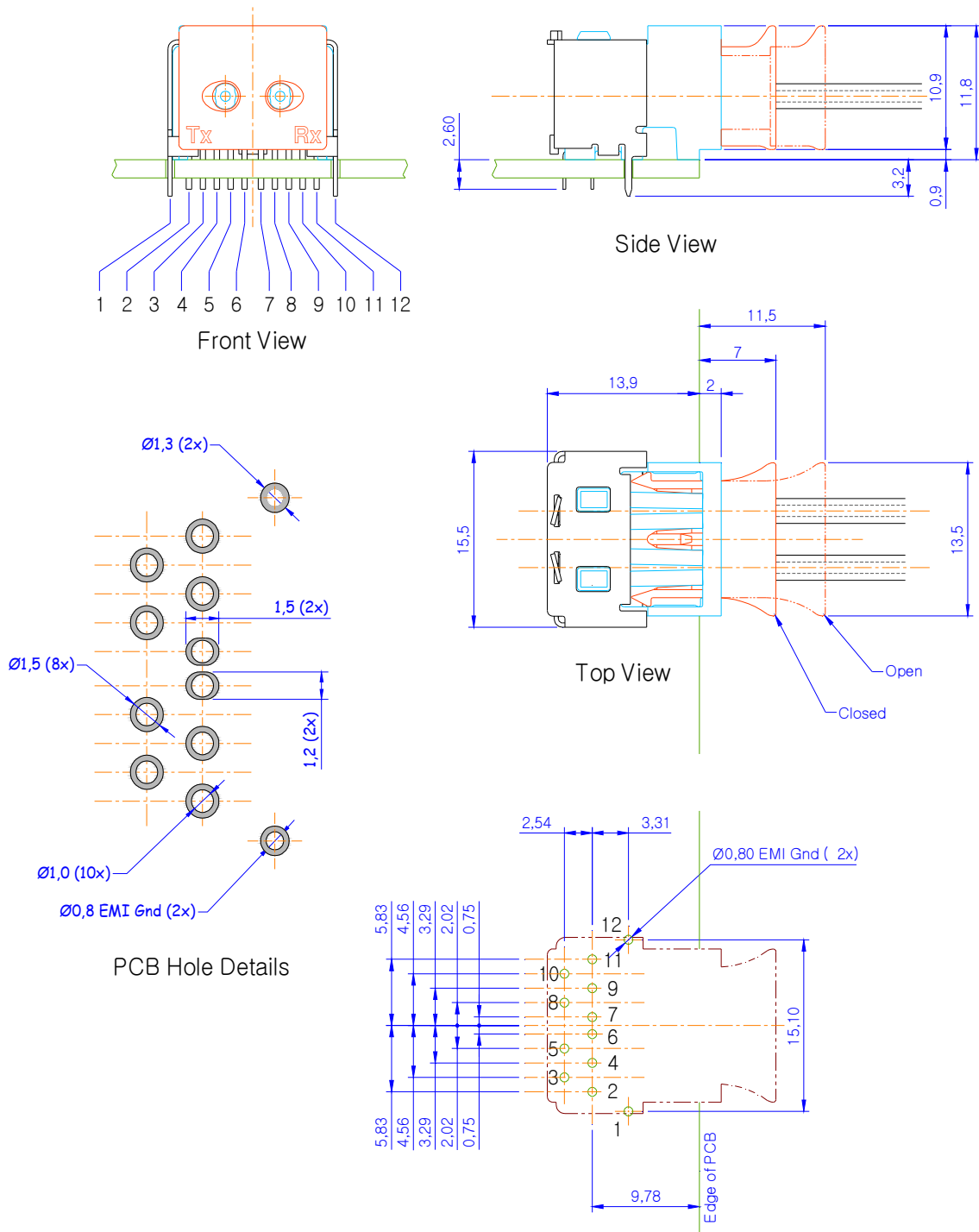

FIGURE 9
PCB layout footprint for EDL301T-xxx.

EDL301T-xxx Revision B

Firecomms assumes no responsibility for inaccuracies or omissions in the information contained in this document. Specifications are subject to change without notice. No patent rights are granted to any of the circuits described herein.

TRANSCEIVER PIN DESCRIPTION

TRANSCEIVER PIN DESCRIPTION		
Pin	Name	Symbol
<i>Receiver</i>		
12	EMI Shield –GND	GND
11	Data Output (Positive)	RD+
10	Data Output (Negative)	RD
9	Signal Detect Output	SD
8	Ground Pin ^[1]	GND
7	DC Power Input Pin 3.3V	V _{CC}
<i>Transmitter</i>		
6	Ground Pin ^[1]	GND
5	DC Power Input Pin 3.3 V	V _{CC}
4	Ground Pin ^[1]	GND
3	Signal Input TX+	TX+
2	Signal Input TX-	TX-
1	EMI Shield –GND	GND

Notes:

1. NB: All ground pins must be connected to the ground plane on the PCB. These pins are not connected internally.

INTERFACE CIRCUIT

The generalized interface circuit is shown in Figure 10. Each PHY IC manufacturer will recommend a termination configuration for their design; please refer to the relevant product data sheets. Some examples from the most popular PHYs are provided in Firecomms' EDL301T Application Note. It is important that the data lines are treated as controlled impedance, matched differential pairs, and that the crystal used in conjunction with the PHY is of a suitably high tolerance.

Signal Detect is an open-collector CMOS output from the receiver (RX). It is low ($\leq 0.6\text{ V}$) when there is no optical data or optical data below the lower optical power sensitivity level. It is high ($\approx 3.3\text{ V}$) when there is optical data present with a power level above the minimum sensitivity level.

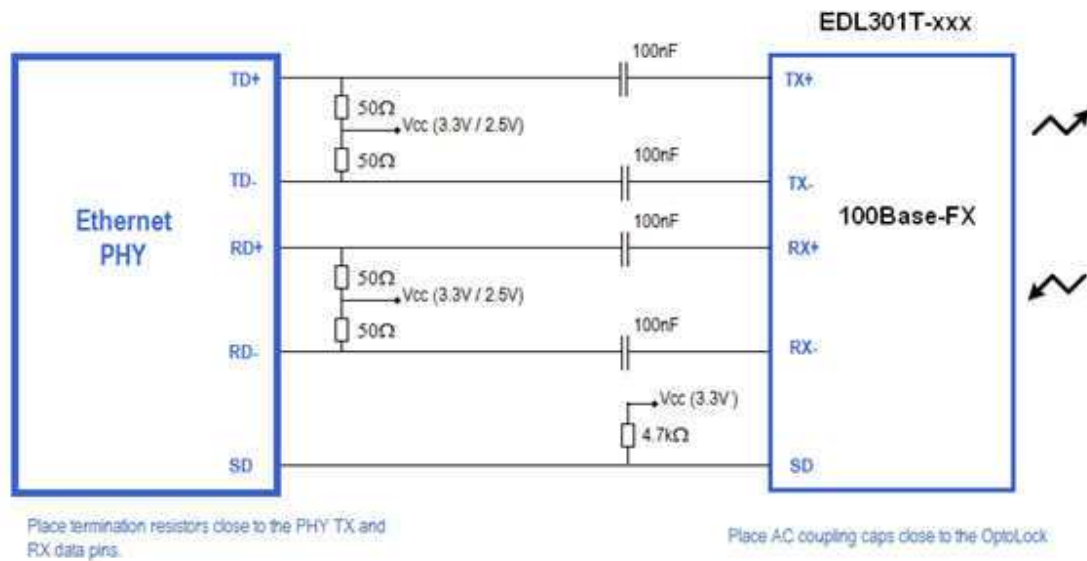

FIGURE 10
Generic Schematic layout for an AC coupled EDL301T-xxx.

ELECTRONIC BLOCK DIAGRAM

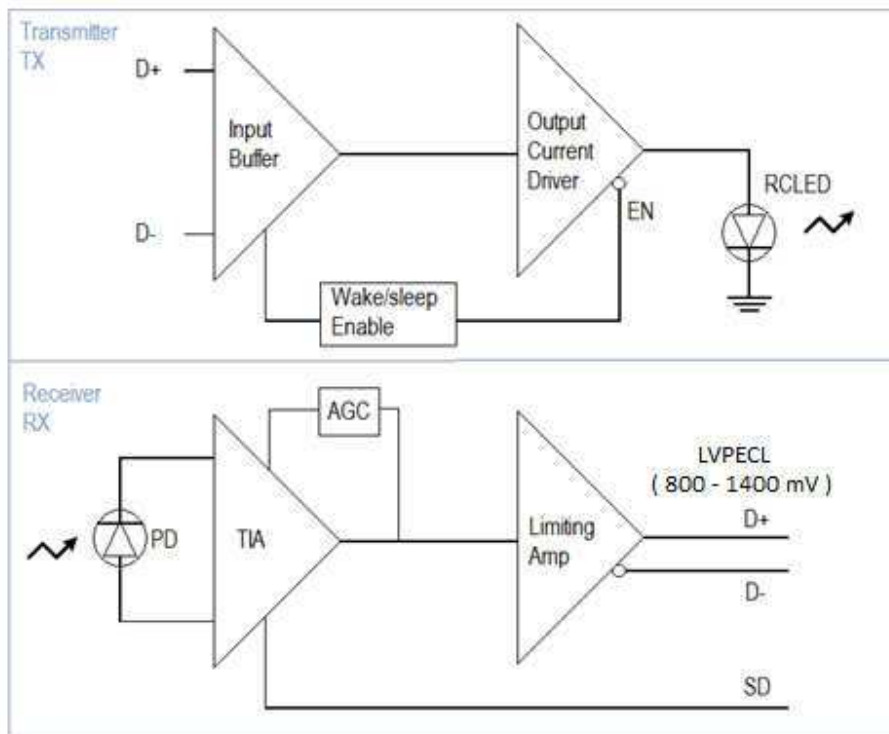

FIGURE 11
Electronic block diagram for the EDL301T-xxx.

ORDERING INFORMATION

ORDERING INFORMATION		
Part Number	Name	Description
EDL301T-220	OptoLock Ethernet Transceiver for 2.2mm POF, Black	650 nm RCLED-Based Transceiver with LVPECL Interface and Termination for Bare 2.2mm POF, Color Black
EDL301T-229	OptoLock Ethernet Transceiver for 2.2mm POF, White	650 nm RCLED-Based Transceiver with LVPECL Interface and Termination for Bare 2.2mm POF, Color White
EDL301T-150	OptoLock Ethernet Transceiver for 1.5mm POF, Black	650 nm RCLED-Based Transceiver with LVPECL Interface and Termination for Bare 1.5mm POF, Color Black
EDL301T-159	OptoLock Ethernet Transceiver for 1.5mm POF, White	650 nm RCLED-Based Transceiver with LVPECL Interface and Termination for Bare 1.5mm POF, Color White

EDL301T-xxx Revision B

Firecomms assumes no responsibility for inaccuracies or omissions in the information contained in this document. Specifications are subject to change without notice. No patent rights are granted to any of the circuits described herein.

PACKING INFORMATION

Components are packed in PVC anti-static tubes in moisture barrier bags. Bags should be opened only in static-controlled locations, and standard procedures should be followed for handling moisture sensitive components.

PACKING INFORMATION		
Components per Tube		25
	Tube Length	440 mm
	Tube Height	20 mm
	Tube Depth	31 mm
Tubes per Bag		10
Bags per Inner Carton		1
	Tube Length	590 mm
	Tube Height	85 mm
	Tube Depth	145 mm
Weight per Inner Carton, Complete		1.8 Kg
Components per Inner Carton		250
Inner Cartons per Outer Carton		4
	Outer Carton Length	600-640 mm
	Outer Carton Height	300 mm
	Outer Carton Depth	200-285 mm
Weight per Outer Carton, Complete		8.6 Kg
Components per Outer Carton		1,000

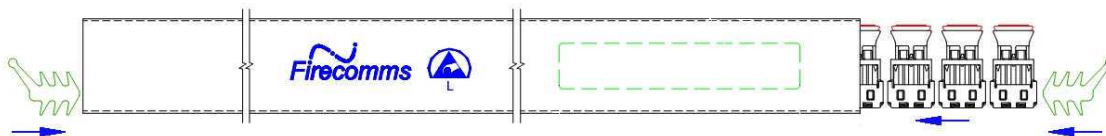

FIGURE 12
Packing tube for the Firecomms transceiver EDL301T.