

Ethernet OptoLock®

EDL300T

DATA SHEET



650 nm 100 Mbps Ethernet Fiber Optic Transceiver with Termination for Bare POF

*Seamless Digital to Light/
Light to Digital Conversion*

FEATURES

- Simple low-cost termination solution for bare POF
- Suitable for 1.5mm or 2.2mm POF
- Compatible with IEEE 802.3u Fast Ethernet data communications standard
- Logic interface compatible with both LVDS (Low-Voltage Differential Signaling) and CML (Current-Mode Logic)
- Integrated CMOS LED driver IC
- Mechanically and electrically interchangeable with Firecomms-enabled SMI connectors
- High-speed Resonant Cavity LED at red 650 nm with small emission aperture suitable for POF
- Resonant Cavity LED reliability tested to over 400,000 hours lifetime
- Integrated high-sensitivity receiver IC and pin-diode for one-step light-to-digital conversion
- Integrated optics to efficiently focus and direct light
- Optimized for high-speed Fast Ethernet of 125 Mbps
- RoHS compliant



DESCRIPTION

Firecomms Ethernet OptoLock® transceiver combines a pair of Firecomms Fast Ethernet fiber optic components within a miniature housing to provide instant termination for bare Plastic Optical Fiber (POF). This POF port significantly quickens and simplifies the connection of devices in communications and infotainment networks.

The design of OptoLock enables the fiber to be cut and terminated to the exact required length on site, allowing even the most novice consumer to quickly and easily terminate the bare optical fiber.



OptoLock is a RCLED-based 650 nm fiber optic solution designed to provide a Fast Ethernet communication link over POF. Firecomms' unique RCLEDs provide high levels of light coupling into the fiber, with short rise and fall times, enabling Ethernet-compliant signaling over large core POF. The simple termination system in the transceiver and the flexibility of POF reduces installation costs to a minimum.

The electrical inputs and outputs are compatible with low-voltage differential signaling levels for simple integration with Ethernet PHY chips.

OptoLock is protected by U.S. patents 7,597,485 and 7,905,665, Chinese patents 101501545 A and 102135650 B and other international patents.

EDL300T Revision A

Firecomms assumes no responsibility for inaccuracies or omissions in the information contained in this document. Specifications are subject to change without notice. No patent rights are granted to any of the circuits described herein.

TERMINATION STEPS

To terminate the POF cable into OptoLock, the end of the cable is cut cleanly, and the two strands are separated. One strand is inserted into each of two holes in the termination housing, which is then pressed closed to hold the POF in place. These steps are shown here.



FIGURE 1
Slice the POF cable.

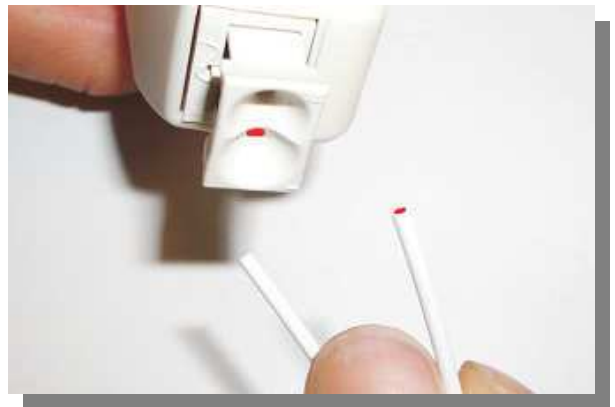

FIGURE 2
Split the POF strands.



FIGURE 3
Insert POF into OptoLock.

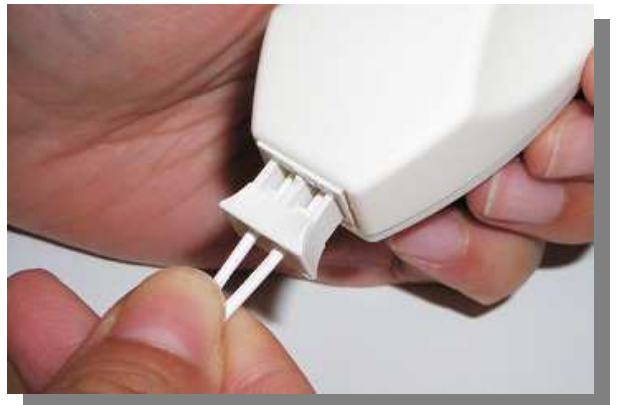

FIGURE 4
Press OptoLock to hold POF into place.

SPECIFICATIONS

ABSOLUTE MAXIMUM RATINGS ⁽¹⁾				
<i>These are the absolute maximum ratings at or beyond which the FOT can be expected to be damaged.</i>				
Parameter	Symbol	Minimum	Maximum	Unit
Storage Temperature	T_{stg}	-40	+85	°C
Operating Temperature	T_{op}	-20	+70	°C
Soldering Temperature ^[2]			+260	°C
Supply Voltage	V_{CC}	-0.5	+4.5	V

Notes:

1. 260°C, 5s 3 times, at least 2.2 mm away from lead root.

TRANSMITTER ELECTRICAL CHARACTERISTICS					
Parameter	Symbol	Minimum	Typical	Maximum	Unit
DC Supply Voltage	V_{CC}	3.0	3.3	3.6	V
Current Consumption	I_{CC}			55	mA
Baud Rate for an 8B/10B Encoded Data Bus	Baud Rate	10	125		MBd
Data Rate		8	100		Mbps
Data Input Capacitance	C_{IN}			5	pF
Data Input Resistance (Single-ended)	R_{IN}		5		kΩ
Input Common-Mode Range	$V_{IN-BIAS}$	GND+0.8		$V_{DD}-0.8$	V
Input Voltage Swing	$V_{IN-SWING}$	100		1200	mV
Optical Power OFF Delay	T_{PD}	0.02		20	μs
Optical Power ON Delay	T_{PU}			5	μs

EDL300T Revision A

Firecomms assumes no responsibility for inaccuracies or omissions in the information contained in this document. Specifications are subject to change without notice. No patent rights are granted to any of the circuits described herein.

SPECIFICATIONS (continued)

TRANSMITTER PIN DESCRIPTION		
Pin	Name	Symbol
1	Data Input (Negative)	TD
2	Data Input (Positive)	TD+
3	Ground Pin	GND
4	Input DC Power Pin	V _{CC}
5	Input, -3dB Power Down (Forces output power to drop by 3dB)	Rex

TRANSMITTER SPECIAL FUNCTIONS	
Function	Description
Rex	<p>The function of the Rex pin is to allow the user to adjust the optical output power of the transceiver by changing the drive current of the RCLED. The pin has three settings:</p> <ol style="list-style-type: none"> (1) <i>Rex is pulled to ground (set to low).</i> This is the default position and in this case the part is set to the internal default drive current of the transceiver. This is the recommended setting for normal operation. (2) <i>The Rex pin is pulled high (set to rail voltage 3.3V).</i> The power of the transceiver is reduced by 3 dBm. This function can be used by a system designer to perform an end of life test. (3) <i>The drive current of the device can be externally set and varied at will by placing a 15k Ohm variable resistor between Rex and ground.</i> It is not recommended to use this for standard operation, especially in applications that are sensitive to current consumption as the external variable resistor can cause higher than normal current consumption.

SPECIFICATIONS (continued)

TRANSMITTER OPTICAL CHARACTERISTICS					
Parameter	Symbol	Minimum	Typical	Maximum	Unit
Peak Wavelength ($T_A = -20$ to 70°C)	λ_{peak}	640	660	670	nm
Spectral Bandwidth (FWHM)	$\Delta\lambda$		23	30	nm
Average Output Power Coupled into Plastic Fiber at $T_A = -20$ to 70°C and 125 Mbps Data Rate	P	-8.5		-2.0	dBm
Optical Rise Time (20%-80%)	t_r		1.5	2.0	ns
Optical Fall Time (80%-20%)	t_f		2.0	3.0	ns
Extinction Ratio	R_E	10.0			dB
Maximum Systematic Jitter at 125 Mbps Coupled into Fiber (Measured after a minimum of 50 cm of POF with 0.3NA)				0.855	ns
Maximum Random Jitter at 125 Mbps Coupled into Fiber (Measured after a minimum of 50 cm of POF with 0.3NA)				0.855	ns

RECEIVER CHARACTERISTICS					
Parameter	Symbol	Minimum	Typical	Maximum	Unit
DC Supply Voltage	V_{CC}	3.0	3.3	3.6	V
Current Consumption	I_{CC}			45	mA
Output Impedance Between D and \underline{D}			100		Ohm
Offset Common Mode Voltage	V_{ocm}		1.2		V
Output Differential Voltage Swing		500		600	mV
SD (Signal Detect) Assert/Deassert Time		0.5	5	100	μs
Receivable Optical Power Sensitivity (SD on)		-24	-26	-28	dBm
Maximum Allowed Optical Power				-2	dBm
Rise/Fall Time (10%-90%)				2	ns

SPECIFICATIONS (continued)**EDL300T Revision A**

Firecomms assumes no responsibility for inaccuracies or omissions in the information contained in this document. Specifications are subject to change without notice. No patent rights are granted to any of the circuits described herein.



RECEIVER PIN DESCRIPTION		
Pin	Name	Symbol
1	Input DC Power Pin	V _{CC}
2	Ground Pin	GND
3	Output Signal Detect	SD
4	Data Input (Negative)	RD
5	Data Input (Positive)	RD+

GENERAL APPLICATION CIRCUIT

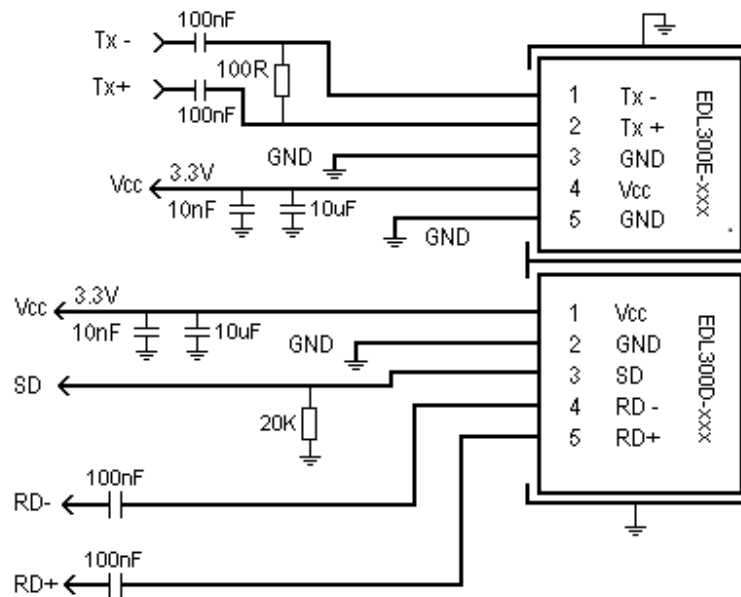

FIGURE 5
General application circuit.

Notes:

1. The Rex pin on the EDL300E-xxx must be connected directly to the ground plane if the external power adjust feature is not being used. If the external power feature is required, please consult the application note or application support at Firecomms.
2. The Tx and Rx FOTs must be electrically shielded from each other to prevent crosstalk. This shield must be grounded. Please see the application note for recommendations on connector options and the PCB layout for standard connectors, such as SMI and OptoLock.
3. Power line capacitors should be located as close to the FOT's DC power pins as possible.
4. The data lines are impedance-matched differential pairs. The PCB layout for these tracks must comply to high-speed data standards for impedance matching.
5. Ethernet PHY interface circuits are available in the application note for the Ethernet FOT devices.

EDL300T Revision A

Firecomms assumes no responsibility for inaccuracies or omissions in the information contained in this document. Specifications are subject to change without notice. No patent rights are granted to any of the circuits described herein.

MECHANICAL DATA

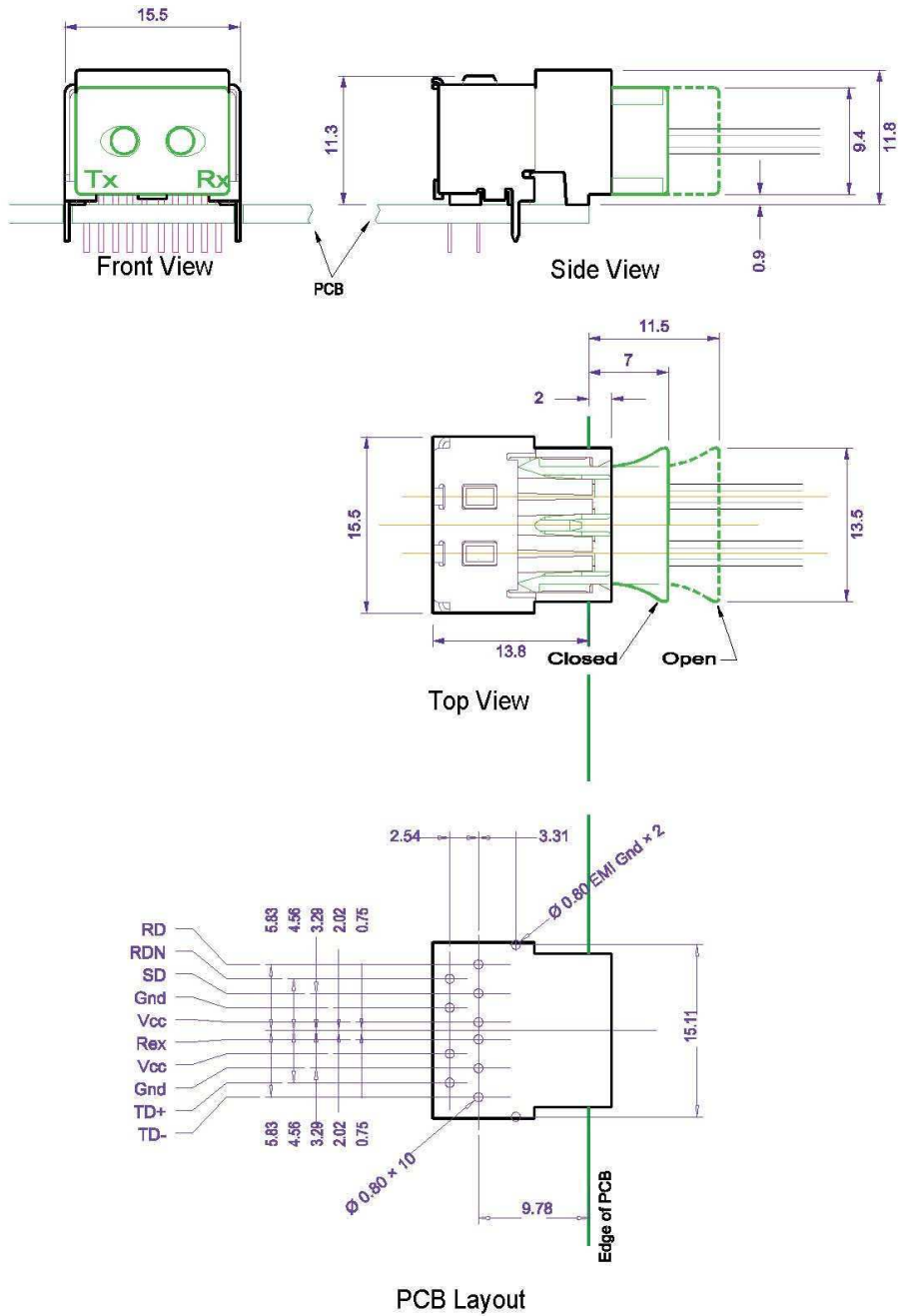

FIGURE 6
PCB layout (top view, looking down) for the Firecomms transceiver EDL300T.

EDL300T Revision A

Firecomms assumes no responsibility for inaccuracies or omissions in the information contained in this document. Specifications are subject to change without notice. No patent rights are granted to any of the circuits described herein.

PACKING INFORMATION

Components are packed in PVC anti-static tubes in moisture barrier bags. Bags should be opened only in static-controlled locations, and standard procedures should be followed for handling moisture sensitive components.

PACKING INFORMATION		
Components per Tube		25
	Tube Length	440 mm
	Tube Height	20 mm
	Tube Depth	31 mm
Tubes per Bag		10
Bags per Inner Carton		1
	Tube Length	590 mm
	Tube Height	85 mm
	Tube Depth	145 mm
Weight per Inner Carton, Complete		1.8 Kg
Components per Inner Carton		250
Inner Cartons per Outer Carton		4
	Outer Carton Length	600-640 mm
	Outer Carton Height	300 mm
	Outer Carton Depth	200-285 mm
Weight per Outer Carton, Complete		8.6 Kg
Components per Outer Carton		1,000

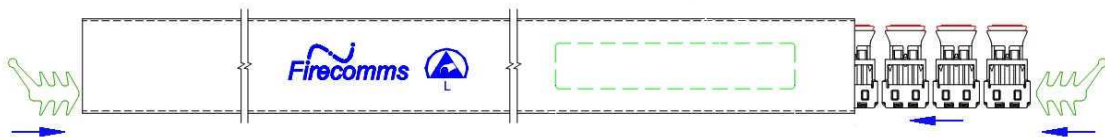

FIGURE 7
Packing tube for the Firecomms transceiver EDL300T.

EDL300T Revision A

Firecomms assumes no responsibility for inaccuracies or omissions in the information contained in this document. Specifications are subject to change without notice. No patent rights are granted to any of the circuits described herein.

ORDERING INFORMATION

ORDERING INFORMATION		
Part Number	Name	Description
EDL300T-150	OptoLock Ethernet Transceiver 1.5mm, Black	650 nm RCLED-Based Transceiver with Termination for Bare POF, Color Black
EDL300T-159	OptoLock Ethernet Transceiver 1.5mm, White	650 nm RCLED-Based Transceiver with Termination for Bare POF, Color White
EDL300T-220	OptoLock Ethernet Transceiver 2.2mm, Black	650 nm RCLED-Based Transceiver with Termination for Bare POF, Color Black
EDL300T-229	OptoLock Ethernet Transceiver 2.2mm, White	650 nm RCLED-Based Transceiver with Termination for Bare POF, Color White

Firecomms Ltd. • 2200 Airport Business Park • Cork, Ireland • Ph +353 (21) 4547100 • Fax +353 (21) 4322657 • www.firecomms.com
 Copyright (c) 2013 Firecomms Ltd. OptoLock is a registered trademark of Firecomms Ltd and is protected by US patents 7,597,485 and 7,905,665, Chinese patents 101501545 A and 102135650 B and other international patents.

EDL300T Revision A

Firecomms assumes no responsibility for inaccuracies or omissions in the information contained in this document.
 Specifications are subject to change without notice. No patent rights are granted to any of the circuits described herein.

