

Analog Sensor OptoLock®

FB00AKAR

DATA SHEET



650 nm Analog Fiber Optic Transceiver for sensor applications over bare POF



FEATURES

- Suitable for analog sensing
- Suitable for both generating and detecting red light
- Visible red light from eye-safe RCLED
- Integrated optics to efficiently focus and direct light to a 1mm fiber core with 0.5/.03 NA
- High bandwidth, low capacitance 500 um silicon photodiode
- RoHS compliant

APPLICATIONS

- Visible red-light sensing
- Interrupter applications
- Security applications
- Remote sensing

DESCRIPTION

Firecomms Analog Fiber Optic Transceiver is a duplex connector with a transmitter that uses a high-speed RCLED and a separate receiver channel which has a high bandwidth low capacitance photo-diode.

The high-speed red 650nm RCLED has optimal optical power at a drive current of approximately 20mA (1.9V forward voltage).

When biased at this drive current modulating signals can be AC coupled to the RCLED using a suitable coupling capacitor (100nF to 470nF) to modulate the optical power and produce a large OMA (optical modulation amplitude).

The receiver is a low capacitance high-speed photo-diode which facilitates receiving light signals from DC up to 125 MHz.

Both the TX and RX are separately encapsulated in clear plastic with molded lensing that is design for optical coupling to 1mm diameter plastic optical fiber with an effective NA of 0.5.

OptoLock is protected by U.S. patents 7,597,485 and 7,905,665, Chinese patents 101501545 A and 102135650 B and other international patents.

FB00AKAR Revision A

Firecomms assumes no responsibility for inaccuracies or omissions in the information contained in this document. Specifications are subject to change without notice. No patent rights are granted to any of the circuits described herein.

TERMINATION STEPS

A POF link is quickly set up by cutting the duplex fiber with a sharp-blade, pulling open the clamp on the front of OptoLock, inserting both sides (the lit fiber to the unlit side of the connector), pushing the fiber into OptoLock until you meet resistance, and locking it in place with the clamp. These steps are shown here:



FIGURE 1
Cut the POF from its reel.

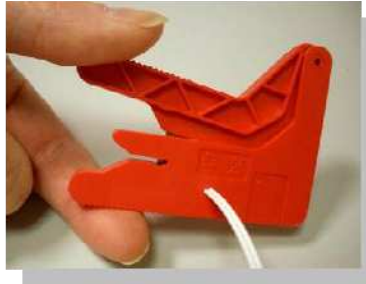

FIGURE 2
Cut a clean finish to the end.



FIGURE 3
Split the duplex POF.

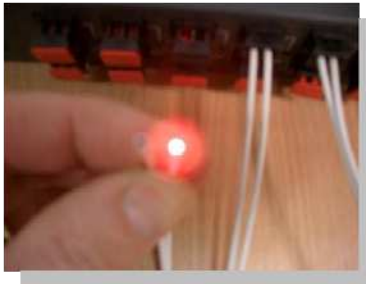

FIGURE 4
Identify the POF core with light.



FIGURE 5
Present the lit POF core to the dark side of OptoLock.



FIGURE 6
Insert and slide POF until it stops.



FIGURE 7
Push in the front clamp to lock POF into place.

SPECIFICATIONS

ABSOLUTE MAXIMUM RATINGS ⁽¹⁾				
<i>These are the absolute maximum ratings at or beyond which the FOT can be expected to be damaged.</i>				
Parameter	Symbol	Minimum	Maximum	Unit
Storage Temperature	T _{stg}	-20	+85	°C
Operating Temperature	T _{op}	-20	+70	°C
Soldering Temperature ^[2]			+260	°C
Supply Voltage (Receiver)	V _{CC}	-0.5	+4.5	V
Receiver Optical Power Overload	P _{OL}		2	dBm
Storage Compliance	MSL		2a	JEDEC20D

Notes:

- These are absolute maximum ratings at or beyond which the FOT can be damaged
- 260°C, 5s 3 times, at least 2.2mm away from lead root.

TRANSMITTER ELECTRICAL AND OPTICAL CHARACTERISTICS						
Parameter	Symbol	Minimum	Typical	Maximum	Unit	Test Condition
Peak Wavelength	λ_{peak}	640	660	670	nm	10 mA, -20°C to 85°C
Forward Voltage	V _f	1.7		2.3	V	10 mA, -20°C to 85°C
Spectral Bandwidth (FWHM)	$\Delta\lambda$	18	24	27	nm	10 mA, -20°C to 85°C
Average Output Power	P	-10	-5.5	0	dBm	10 mA, -20°C to 85°C
Change in Optical Power over Temp	ΔP			5	dB	10 mA, -20°C to 85°C
Optical Rise Time (20%-80%)	T _R	0.50	1.30	2.50	ns	0-2 V Square Wave
Optical Fall Time (80%-20%)	T _F	0.40	0.50	2	ns	0-2 V Square Wave
Cut off Frequency (-3dB Optical power)	f _c	5		100	MHz	Min @ 10 mA bias Max @ 20 mA bias
Capacitance	C ₀		5		pF	V _f =0 V, f=1 MHz

FB00AKAR Revision A

Firecomms assumes no responsibility for inaccuracies or omissions in the information contained in this document. Specifications are subject to change without notice. No patent rights are granted to any of the circuits described herein.

SPECIFICATIONS (Transmitter)

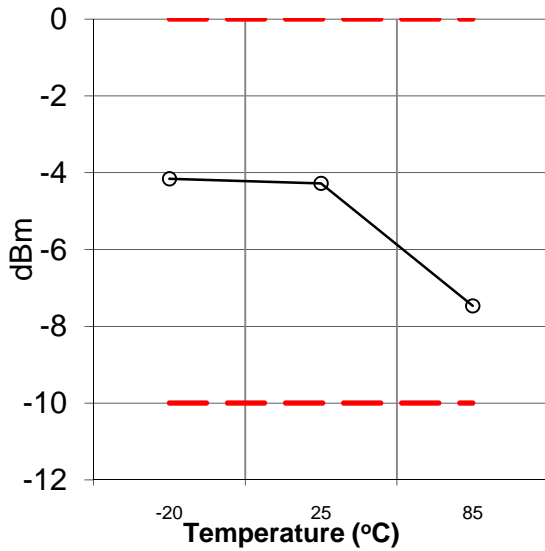

FIGURE 8: Average POF Coupled Optical Power / dBm for $I_f = 10$ mA, against temperature

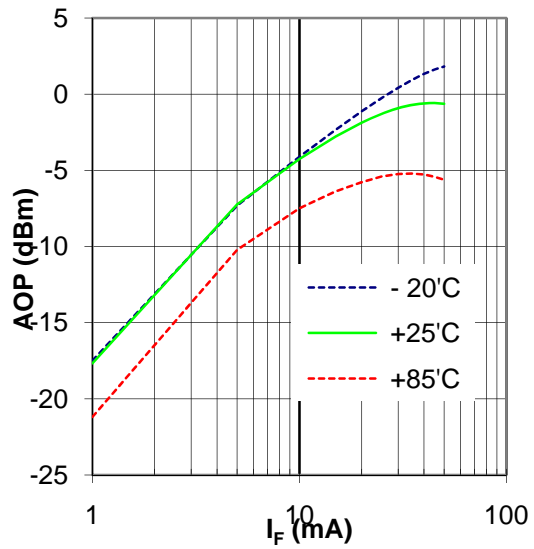

FIGURE 9: Average POF Coupled Optical Power (dBm) against forward current I_f (mA)

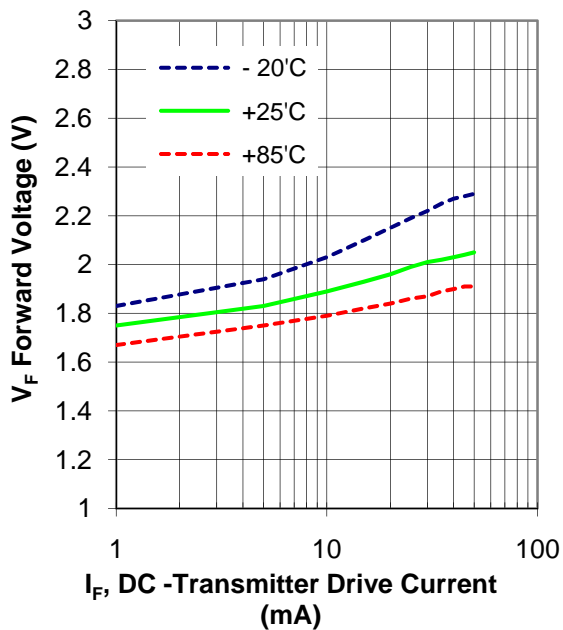

FIGURE 10: Forward Voltage V_f (V) against forward current I_f (mA)

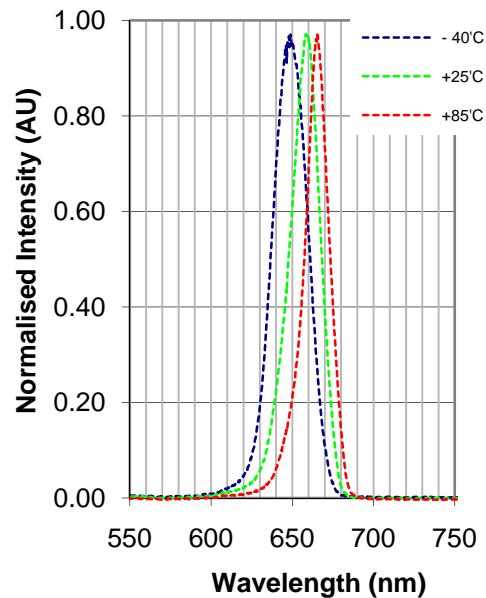

FIGURE 11: Normalized Intensity (AU) against Wavelength (nm)

SPECIFICATIONS (Receiver)

RECEIVER ELECTRICAL AND OPTICAL CHARACTERISTICS					
Parameter	Symbol	Minimum	Typical	Maximum	Unit
Responsivity @ 650 nm	R		0.3	0.42	A/W
Dark Current	I_R		0.2	1.0	mA
Upper Cut off Frequency	$f_{c, -3dB}$		125	300	MHz
Dark Noise Density			10		fA/√Hz
Optical Rise Time (20% - 80%)	t_r		1		ns
Optical Fall Time (80% - 20%)	T_f		1		ns
Capacitance (for bias = 8V, f= 1MHz)	C_0		3		pF

MECHANICAL INFORMATION

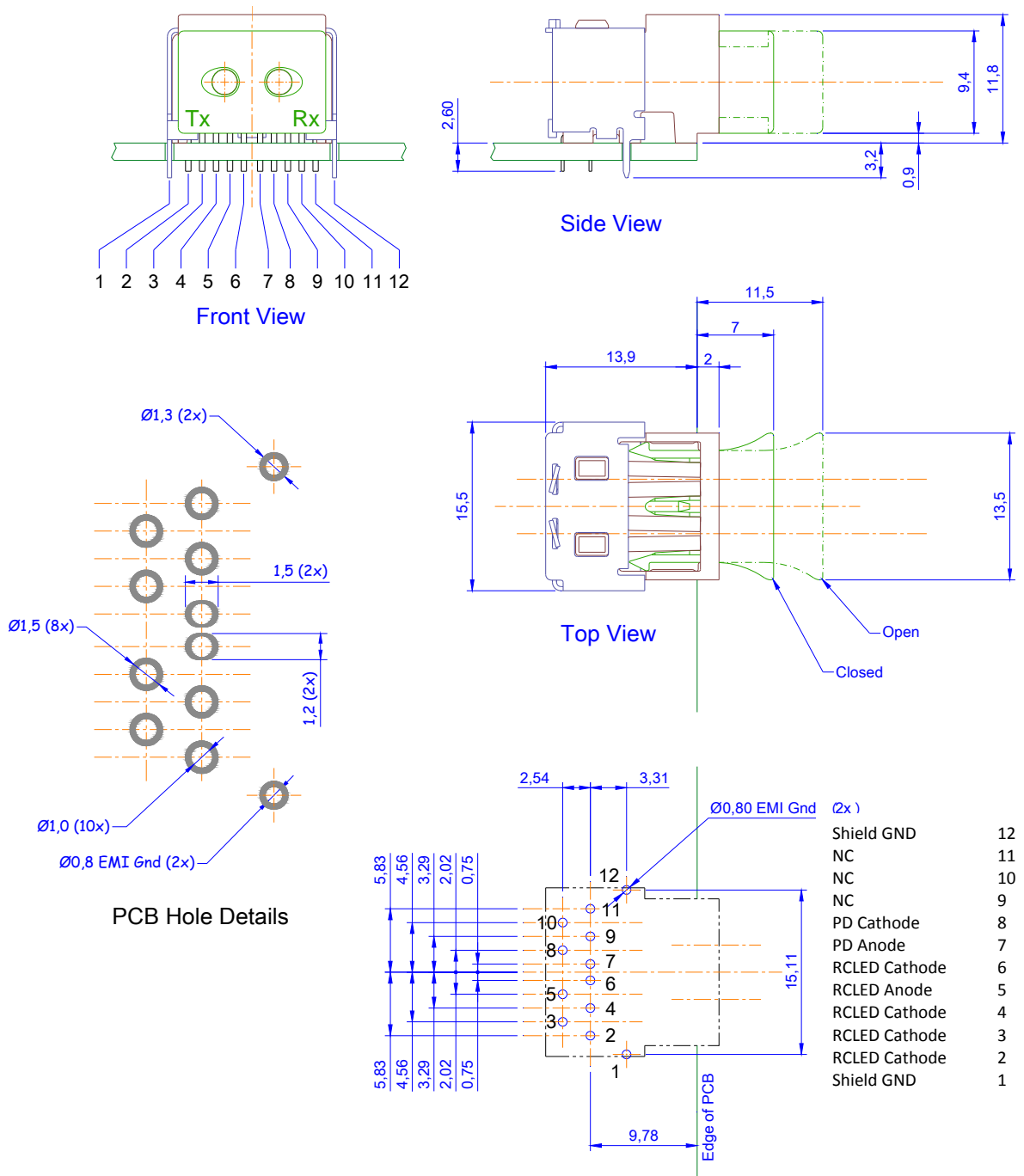

FIGURE 12
PCB layout footprint for FB00AKAR.

TRANSCEIVER PIN DESCRIPTION

TRANSCEIVER PIN DESCRIPTION		
Pin	Name	Symbol
<i>Receiver</i>		
12	EMI Shield – GND ^[1]	GND
11	Not Connected	NC
10	Not Connected	NC
9	Not Connected	NC
8	PD Cathode	RD-
7	PD Anode	RD+
<i>Transmitter</i>		
6	RCLED CATHODE	TX-
5	RCLED ANODE	TX+
4	RCLED CATHODE	TX-
3	RCLED CATHODE	TX-
2	RCLED CATHODE	TX-
1	EMI Shield –GND ^[1]	GND

Notes:

1. NB: EMI Shield ground pins must be connected to the signal ground plane on the PCB. This is important to prevent cross-talk between TX and RX and also to shield the FOT's from external EMI/EMC and ESD.



FIGURE 13:
Side views of the OptoLock with dust cap, without dust cap and with POF inserted

FB00AKAR Revision A

Firecomms assumes no responsibility for inaccuracies or omissions in the information contained in this document. Specifications are subject to change without notice. No patent rights are granted to any of the circuits described herein.

INTERFACE CIRCUIT

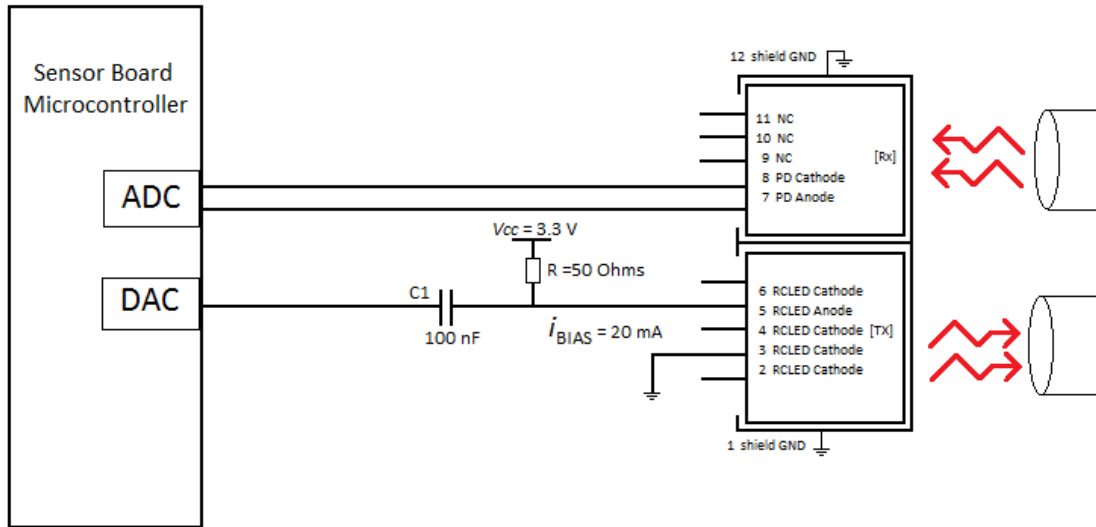

FIGURE 14
Schematic layout for an AC coupled FB00AKAR.

Bias is set at 20mA using a 50 Ohm resistor and the FOT bias line of 3.3V. This gives optimum optical power for modulation. The AC coupling capacitor value should be chosen based on the best match to the frequency content of the drive signal. In general a value between 100 nF and 470 nF is recommended.

ORDERING INFORMATION

ORDERING INFORMATION		
Part Number	Name	Description
FB00AKAR	OptoLock Analog Sensor OptoLock for 2.2mm POF,	650 nm RCLED-Based Analog Sensor with 650nm RCLED and 500um PD in a Black Body with termination for bare 2.2mm POF

PACKING INFORMATION

Components are packed in PVC anti-static tubes in moisture barrier bags. Bags should be opened only in static-controlled locations, and standard procedures should be followed for handling moisture sensitive components.

PACKING INFORMATION		
Components per Tube		25
	Tube Length	440 mm
	Tube Height	20 mm
	Tube Depth	31 mm
Tubes per Bag		10
Bags per Inner Carton		1
	Tube Length	590 mm
	Tube Height	85 mm
	Tube Depth	145 mm
Weight per Inner Carton, Complete		1.8 Kg
Components per Inner Carton		250
Inner Cartons per Outer Carton		4
	Outer Carton Length	600-640 mm
	Outer Carton Height	300 mm
	Outer Carton Depth	200-285 mm
Weight per Outer Carton, Complete		8.6 Kg
Components per Outer Carton		1,000

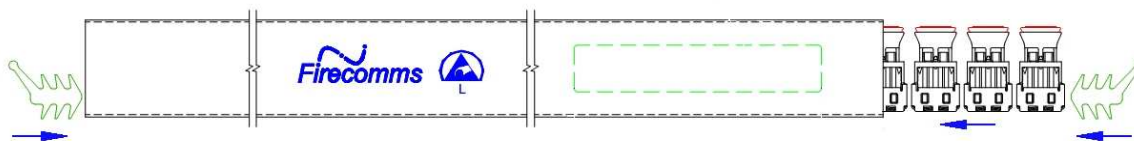

FIGURE 15
Packing tube for the Firecomms transceiver FB00AKAR.