

Ethernet LC Evaluation Kit

EVAL-FB1M2LPR

EVALUATION KIT



Ethernet LC Evaluation Kit User Guide

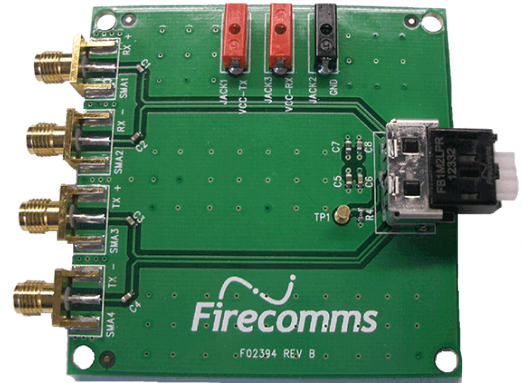

OVERVIEW

The EVAL-FB1M2LPR Evaluation Kit enables evaluation of the Firecomms LC connector for plastic optic fiber (POF) and large core glass fiber (200, 400 um PCS). The kit includes a single piece of the LC connector pre-mounted onto a simple PCB that allows easy application of DC power via standard 2 mm diameter DC jacks. Data input (TX) and data output (RX) are via standard screw terminal SMA connectors.

For particular POF or PCS lengths and assemblies please contact Firecomms Applications support directly.

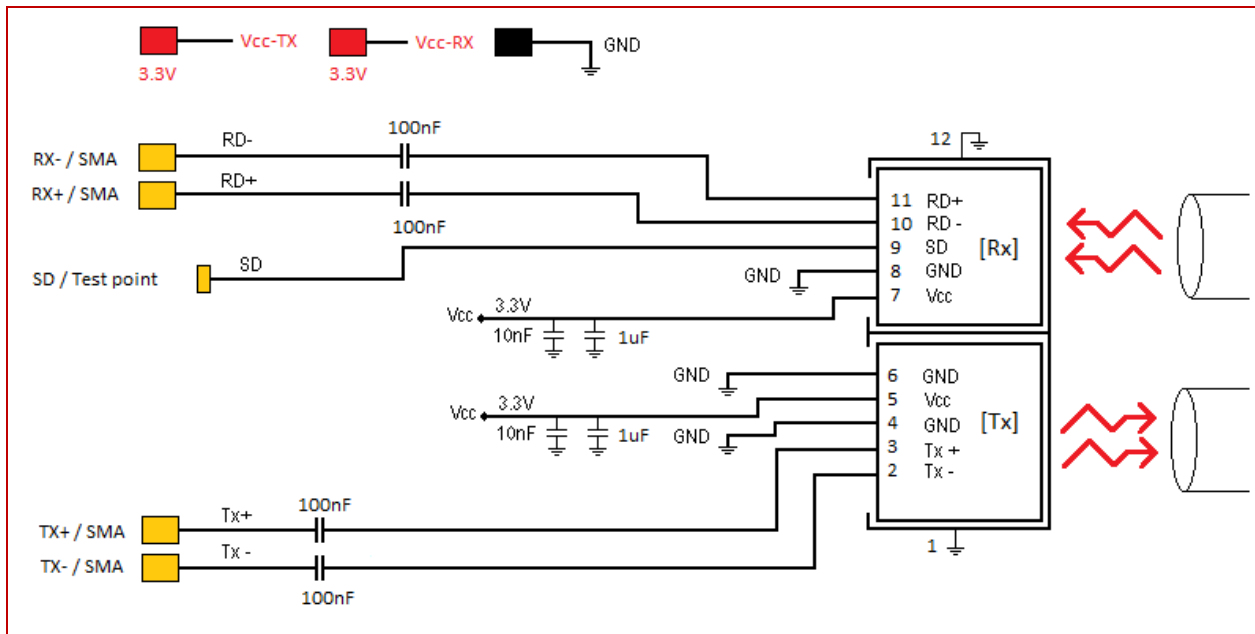

FIGURE 1
Layout of the LC Evaluation PCB.

EVALUATION KIT CONTENTS

The Evaluation Kit contains the following:

1. Evaluation PCB
2. FB1M2LPR mounted onto the test PCB
3. POF cable (1 m, 0.5 NA, 2.2 mm jacket duplex POF) with LC termination connectors
4. Data sheet

INITIAL SETUP

1. Connect GND of a DC power supply to the ground point of the PCB (black terminal).
2. Connect 3.3V to each of the TX and RX VCC jacks (red terminals).
3. Connect an oscilloscope probe (1M Ω) to the Signal Detect (SD) test point.
4. Connect a suitable pattern generator differential data signals via SMA cables to the TX +/- data pins.
5. Connect the RX +/- data pins to a suitable high speed oscilloscope using 50 Ω termination and high-speed coax, SMA terminated cables.
6. For a loop-back cable test, connect the LC Loop back cable provided into the LC connector. The cable brings the TX optical signal back into the RX over 1m of Step-Index POF.

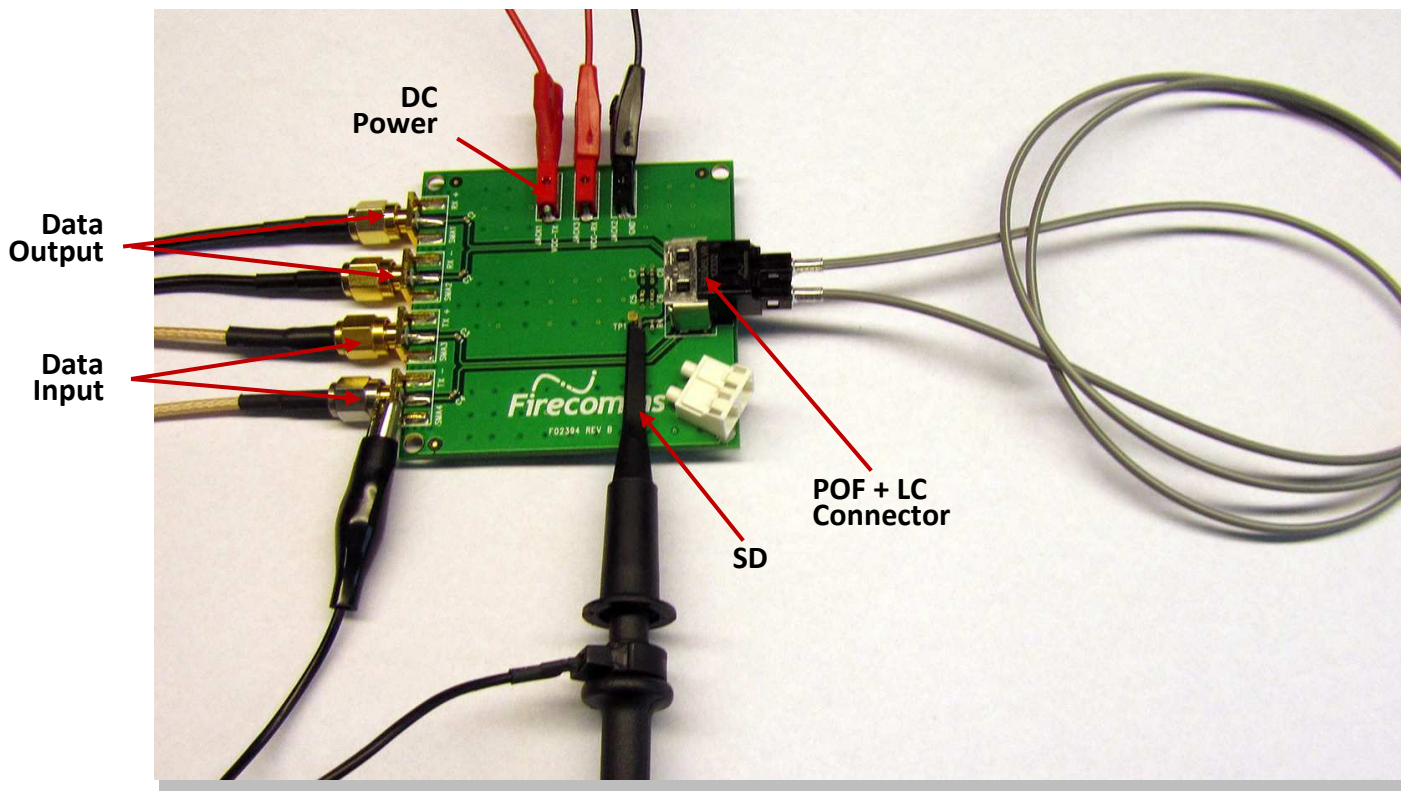

FIGURE 2
Setup of the Evaluation PCB.