

# 125 Mbps Industrial Ethernet Transceiver in LC FB1M2LPR

DATA SHEET



## 650 nm Fiber Optic Transceiver for Industrial Ethernet with LC Termination

*LVPECL I/O*

*IEC 61754-20 Compliant*



### FEATURES

- LC connector system for use with POF and PCS
- Compatible with IEEE 802.3u Fast Ethernet over fiber 100Base-FX data communications standard
- Red visible 650 nm Resonant Cavity LED (RCLED)
- Integrated CMOS driver IC for RCLED
- High sensitivity CMOS receiver IC and PIN diode
- Integrated optics to efficiently focus and direct light
- -40° to +85°C operating range
- RoHS compliant

### APPLICATIONS

Table 1 APPLICATIONS	
Application	Industrial Networking
Standard	IEEE 802.3 (100Base-FX) IEC 61754-20
Distance	50 meters Step Index POF 100 meters PCS <sup>[1]</sup>
Speed	10/100 Ethernet

1. Depending on the installation conditions.

### DESCRIPTION

Firecomms duplex LC connector for Fast Ethernet combines both transmitter and receiver fiber optic components in a small form factor LC housing. The LC connector allows termination of LC cable plugs with both standard 2.2 mm jacketed Plastic Optical Fiber (POF) and Plastic Clad Silica (PCS) multimode glass fibers used for extended distance applications. With a very simple circuit interface to any standard Ethernet PHY IC supporting 100Base-FX (IEEE 802.3), the connector provides Ethernet bandwidth of 100 Mb over POF in a point-to-point LAN.

The connector system complies with the international LC standard IEC 61754-20. This design enables the use of POF with the popular LC connector in industrial LAN applications.

The transmitter is a high-speed RCLED driven by a CMOS IC. The receiver combines a photo-diode, trans-impedance amplifier and limiting amplifier, providing a digital output on an LVPECL-type data bus compatible with all Ethernet PHY ICs.

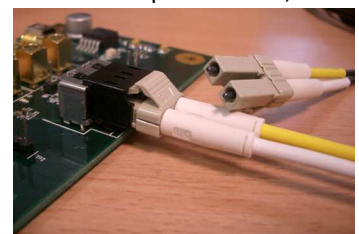

#### FB1M2LPR Revision A

Firecomms assumes no responsibility for inaccuracies or omissions in the information contained in this document. Specifications are subject to change without notice. No patent rights are granted to any of the circuits described herein.

**SPECIFICATIONS**

Table 2 ABSOLUTE MAXIMUM RATINGS				
<i>These are the absolute maximum ratings at or beyond which the FOT can be expected to be damaged.</i>				
Parameter	Symbol	Minimum	Maximum	Unit
Storage Temperature	$T_{stg}$	-40	+85	°C
Operating Temperature	$T_{op}$	-40	+85	°C
Soldering Temperature <sup>[1]</sup>	$T_{sld}$		+260 <sup>[1]</sup>	°C
Supply Voltage	$V_R$	-0.5	4.5	V
Receiver Optical Overload	$P_{OL}$		0	dBm
Storage Compliance	MSL		2a	J-STD-020D

Notes:

1. 260°C for 10 sec, 1 time only, at least 2.2 mm away from lead root.

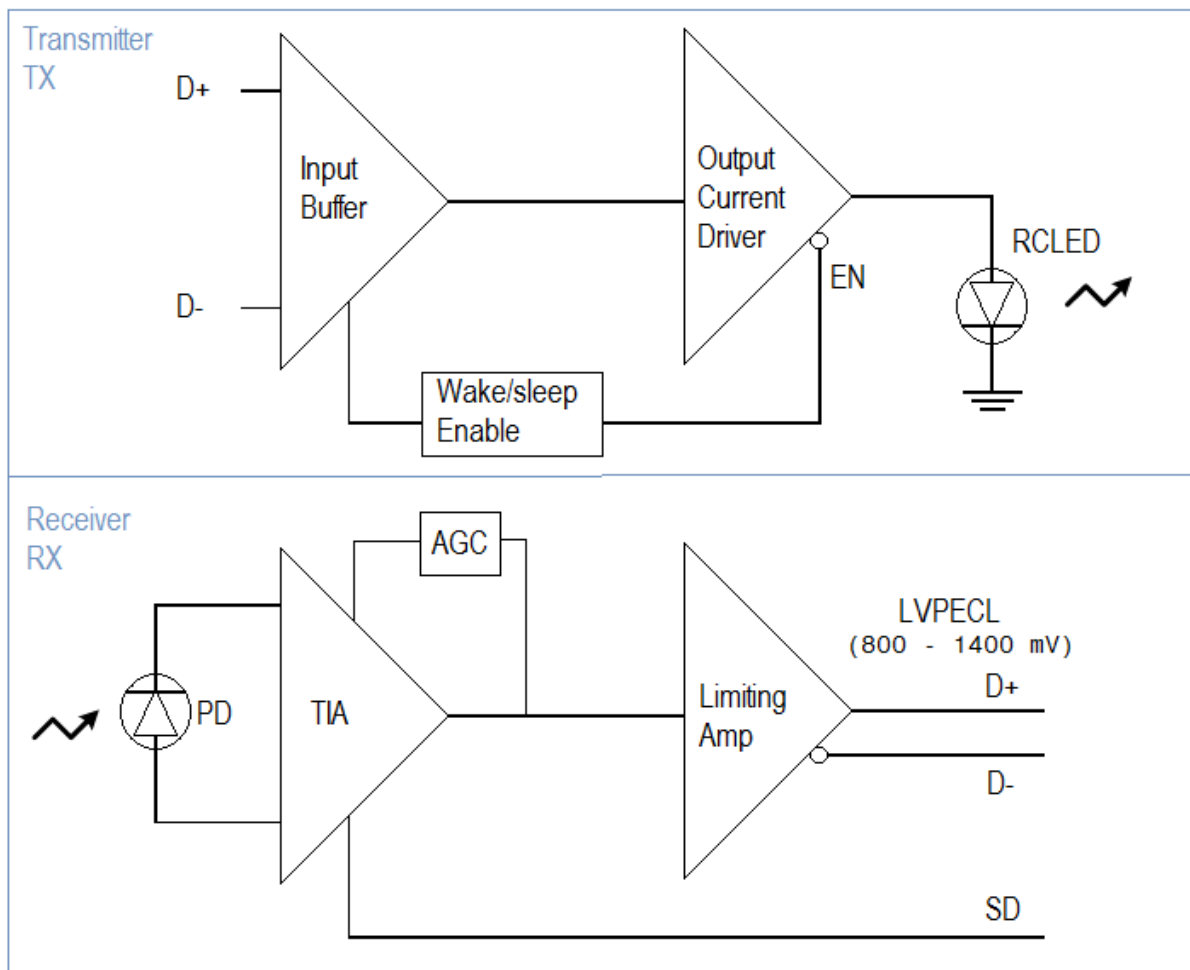

**FIGURE 1**  
Electronic block diagrams of the TX and RX fiber optic transceivers

## SPECIFICATIONS (continued)

**Table 3**  
**TRANSMITTER ELECTRICAL AND OPTICAL CHARACTERISTICS**

*Test Conditions:*

1. Test data was validated over the full temperature range of -40°C to +85°C, and over the supply range of 3V to 3.6V.
2. Test data represents operation at the maximum data rate of 125 Mbps using a PRBS7 test pattern (8B/10B encoding) unless otherwise stated.
3. Optical power is measured when coupled into 0.5 m of a 1 mm diameter 0.5 NA plastic fiber.

Parameter	Symbol	Minimum	Typical	Maximum	Unit
DC Supply Voltage	V <sub>CC</sub>	3.0	3.3	3.6	V
Operating Current Consumption	I <sub>CC</sub>	30	37	52	mA
Data Rate		10		125	Mbps
Data Input Capacitance	C <sub>IN</sub>			5	pF
Data Input Resistance (Single-Ended)	R <sub>IN</sub>		5		kΩ
Input Common-Mode Range	V <sub>IN-BIAS</sub>	GND+0.8		V <sub>CC</sub> -0.8	V
Input Voltage Swing	V <sub>IN-SWING</sub>	100		1200	mV
Minimum Differential Voltage Swing to Ensure Wake-Up	Wake-up Input	50			mV
Wake-Up Time Delay			5	80	μs
Optical Power OFF Delay		0.02		20	μs
Peak Wavelength	λ <sub>peak</sub>	640	660	670	nm
Spectral Bandwidth (FWHM)	Δλ	18	24	27	nm
Average Optical Power	P	-10	-5.5	-1.5	dBm
Optical Rise Time (20%-80%)	t <sub>R</sub>	0.5	1.3	3.1	ns
Optical Fall Time (80%-20%)	t <sub>F</sub>	0.4	0.5	0.75	ns
Optical Modulation Amplitude (OMA)	OMA	160	590	1250	μW
Open Eye Width	T <sub>eye</sub>	6.5	7.4	7.9	ns

**SPECIFICATIONS (continued)**

**Table 4  
RECEIVER CHARACTERISTICS**

*Test Conditions:*

1. Test data was validated over the full temperature range of -40°C to +85°C, and over the supply range of 3V to 3.6V.
2. Test data represents operation at the maximum data rate of 125 Mbps using a PRBS7 test pattern (8B/10B encoding) unless otherwise stated.
3. Optical power was coupled from a minimum 0.5 m length of 1 mm diameter core and 0.5 NA step index plastic optic fiber.

Parameter	Symbol	Minimum	Typical	Maximum	Unit
DC Supply Voltage	V <sub>CC</sub>	3.0	3.3	3.6	V
Operating Current Consumption	I <sub>CC</sub>	35	43	50	mA
Output Impedance Between D and <u>D</u>	R <sub>Diff</sub>		100		Ohm
Offset Common Mode Voltage	V <sub>ocm</sub>		1.41		V
Output Differential Voltage Swing		800	1150	1400	mV
Receivable Optical Power Sensitivity			-26	-24	dBm
Maximum Allowed Optical Power				0	dBm
Rise Time (10%-90%)			1.6	3.4	ns
Fall Time (90%-10%)			1.6	3.4	ns
Signal Detect Assert/De-Assert Time	T <sub>SD</sub>	0.1	0.3	0.6	us
Signal Detect Optical Assert Level	P <sub>SD-AS</sub>	-32	-27	-24	dBm
Signal Detect Optical De-Assert Level	P <sub>SD-DAS</sub>	-32	-28	-25	dBm
Signal Detect Voltage High	V <sub>SDH</sub>	2.4	3.0	3.6	V
Signal Detect Voltage Low	V <sub>SDL</sub>	0.0	0.05	0.1	V
Open Eye Width	EW	5.7	7.4	7.9	ns

**SPECIFICATIONS (continued)**

Table 5 TRANSCEIVER PIN DESCRIPTION		
Pin	Name	Symbol
TRANSMITTER		
1	EMI Shield-GND	GND
2	Signal Input TX-	TX-
3	Signal Input TX+	TX+
4	Ground Pin <sup>[1]</sup>	GND
5	DC Power Input Pin 3.3V	Vcc
6	Ground Pin <sup>[1]</sup>	GND
RECEIVER		
7	DC Power Input Pin 3.3V	Vcc
8	Ground Pin	GND
9	Signal Detect Output	SD
10	Data Output (Negative)	RD-
11	Data Output (Positive)	RD+
12	EMI Shield-GND	GND

## Notes:

- Both ground pins must be connected to the ground plane on the PCB. These pins are not connected internally.



**FIGURE 2**  
LC connector shown with dust plug, as open connector, and with LC plug inserted

**APPLICATION CIRCUIT**

Following is the general interface circuit. Each Ethernet PHY manufacturer recommends a termination configuration for its design. Examples of the most commonly used PHYs are given in the Firecomms Ethernet Application Note.

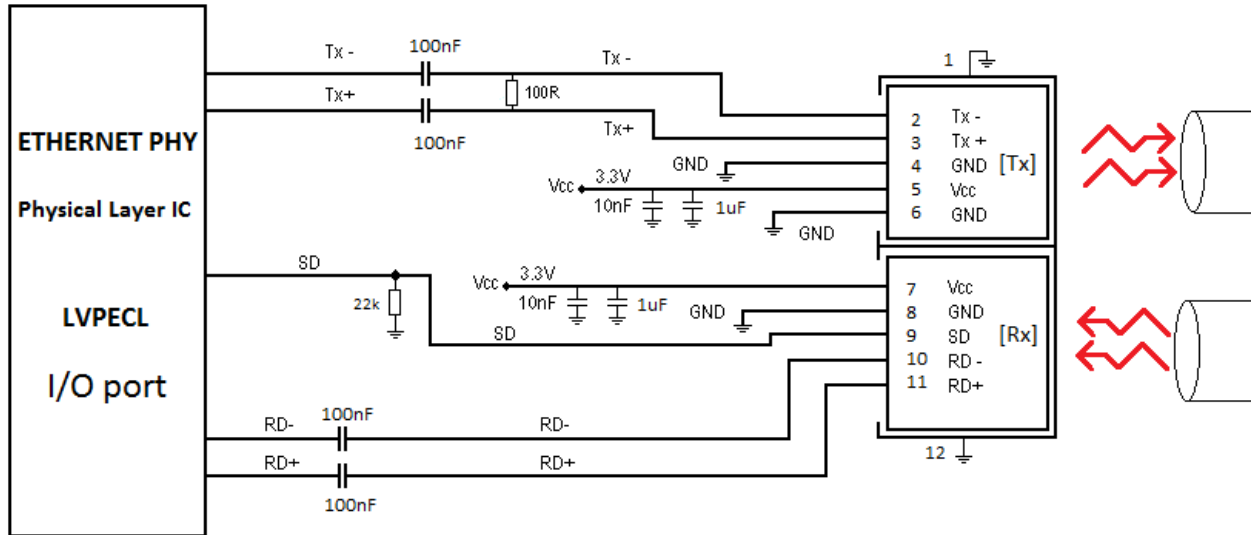

**FIGURE 3**  
Interface circuit schematic to AC couple to an Ethernet PHY

Notes:

1. The transmitter (TX) and receiver (RX) are electrically shielded from each other to prevent crosstalk. To be effective this shield must be grounded.
2. Both GND pins of the TX FOT must be connected to GND (they are not connected internally).
3. Power line capacitors should be located as close as possible to the FOT's DC power PINs.
4. The data lines are impedance-matched differential pairs. The PCB layout for these tracks must comply to IEEE standards for high-speed data and impedance matching.

**MECHANICAL DATA**



**FIGURE 4**  
LC connector as viewed from different angles

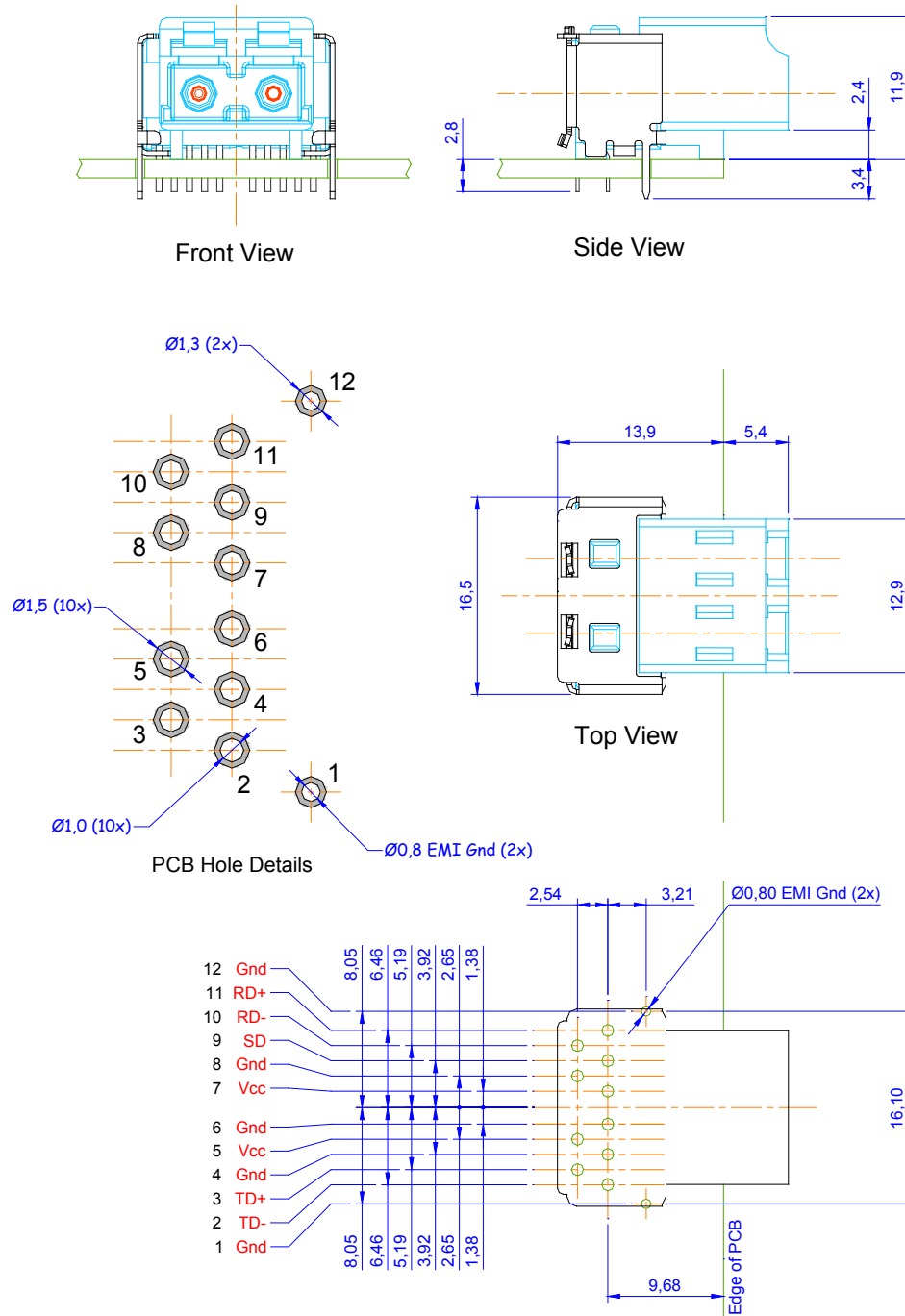
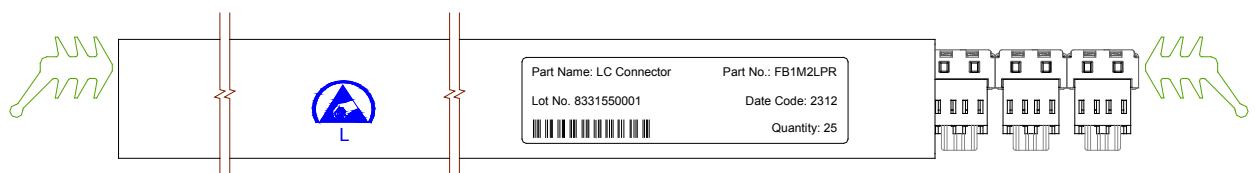

**FIGURE 5**  
Mechanical dimensions of the LC connector and PCB footprint, which is a top view. General dimensional tolerance is  $\pm 0.2$ mm.

**PACKING INFORMATION**

Components are packed in PVC anti-static tubes in moisture barrier bags. Bags should be opened only in static-controlled locations, and standard procedures should be followed for handling moisture sensitive components.

Table 6 PACKING INFORMATION		
Components per Tube		25
	Tube Length	440 mm
	Tube Height	27.4 mm
	Tube Width	19.4 mm
Tubes per Bag		10
Bags per Inner Carton		1
	Inner Carton Length	588 mm
	Inner Carton Height	82 mm
	Inner Carton Width	147 mm
Weight per Inner Carton, Complete		1.7 Kg
Components per Inner Carton		250
Inner Cartons per Outer Carton		4
	Outer Carton Length	600-640 mm
	Outer Carton Height	179 mm
	Outer Carton Width	300 mm
Weight per Outer Carton, Complete		8.1 Kg
Components per Outer Carton		1,000



**FIGURE 6**  
Packing tube for the Firecomms LC transceiver system

**ORDERING INFORMATION**

Table 7 ORDERING INFORMATION		
Part Number	Name	Description
FB1M2LPR	LC Transceiver for Fast Ethernet over POF/PCS	650 nm RCLED-Based Transceiver, Color Black, with LVPECL I/O and Termination for LC Plug with PCS/POF