

# Industrial Ethernet Transceiver in OptoLock<sup>®</sup>

## FB1M2KPR

DATA SHEET



### 650 nm Fiber Optic Transceiver for Industrial Ethernet with Optolock<sup>®</sup> Termination

LVPECL I/O



#### FEATURES

- Simple low-cost termination solution for 2.2 mm jacketed POF cables without a plug
- Compatible with IEEE 802.3u Fast Ethernet over fiber 100Base-FX data communications standard
- Compatible with Ethernet PHYs supporting 100Base-FX
- Resonant Cavity LED (RCLED) at red 650 nm with small emission aperture suitable for POF
- RCLED reliability tested to over 400,000 hours lifetime
- Integrated CMOS driver IC for RCLED
- High sensitivity CMOS receiver IC and PIN diode for one-step light to digital conversion
- Integrated optics to efficiently focus and direct light
- -40° to +85°C operating range
- RoHS compliant

#### APPLICATIONS

Table 1 APPLICATIONS	
Application	Industrial Networking
Standard	IEEE 802.3 (100Base-FX)
Distance	50 meters Step Index POF <sup>[1]</sup>
Speed	100 Mbps

Note:

1. Depending on the installation conditions.

#### DESCRIPTION

Firecomms Industrial OptoLock<sup>®</sup> transceiver has a small form factor housing which combines a pair of Firecomms fiber optic components to provide instant termination for bare Plastic Optical Fiber (POF). As this POF port significantly simplifies the optical connection, it reduces maintenance time for industrial equipment.

This version of OptoLock carries a pair of Fast Ethernet Fiber Optic Transceivers (FOTs) designed to provide



Ethernet data links over POF in industrial environments. The FOTs are compatible with LVPECL which is the standard bus for a Fast Ethernet physical layer interface IC supporting the IEEE 100Base-FX standard. The interface circuit is simple AC coupling to the PHY's data pins. Signal detect on the RX provides a link on/off diagnostic for the PHY and can be used for power saving.

OptoLock is protected by U.S. patents 7,597,485 and 7,905,665, Chinese patents 101501545 A and 102135650 B and other international patents.

## TERMINATION STEPS

To terminate the POF cable into OptoLock, the end of the cable is cut cleanly, and the two strands are separated. One strand is inserted into each of two holes in the termination housing, which is then pressed closed to hold the POF in place. These steps are shown here.

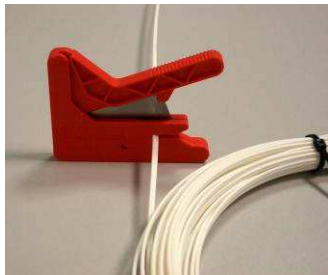

**FIGURE 1**  
Slice the POF cable.

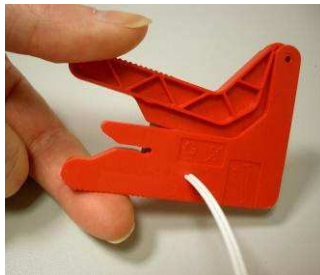

**FIGURE 2**  
Cut a clean finish to the end.



**FIGURE 3**  
Split the duplex POF.

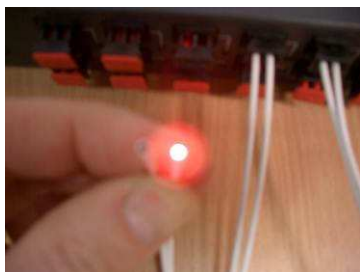

**FIGURE 4**  
Identify the POF core that is lit.



**FIGURE 5**  
Present the lit core to the dark OptoLock side.



**FIGURE 6**  
Insert both strands into OptoLock.



**FIGURE 7**  
Push home to lock the clamp.

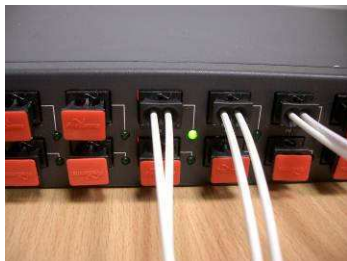

**FIGURE 8**  
If the link is fully connected the indicator LED will flash showing activity on the Ethernet link.

**SPECIFICATIONS**

Table 2 ABSOLUTE MAXIMUM RATINGS				
<i>These are the absolute maximum ratings at or beyond which the FOT can be expected to be damaged.</i>				
Parameter	Symbol	Minimum	Maximum	Unit
Storage Temperature	$T_{stg}$	-40	+85	°C
Operating Temperature <sup>[1]</sup>	$T_{op}$	-40	+85	°C
Soldering Temperature <sup>[1]</sup>	$T_{sld}$		+260 <sup>[1]</sup>	°C
Supply Voltage	$V_R$	-0.5	4.5	V
Receiver Optical Overload	$P_{OL}$		0	dBm
Storage Compliance	MSL		2a	J-STD-020D

Notes:

1. 260°C for 10 sec, 1 time only, at least 2.2 mm away from lead root.

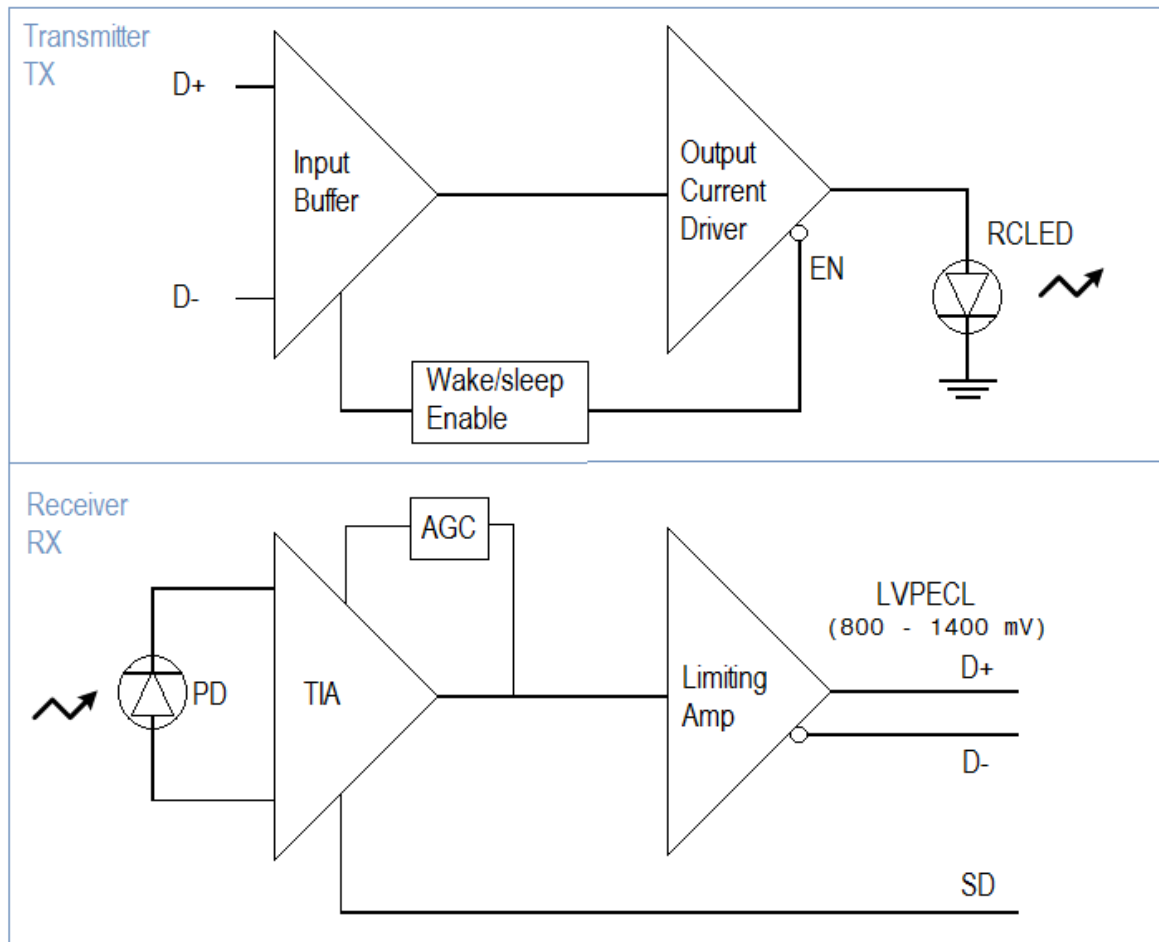

**FIGURE 9**  
Electronic block diagrams of the TX and RX fiber optic transceivers

**SPECIFICATIONS (continued)**

**Table 3  
TRANSMITTER ELECTRICAL AND OPTICAL CHARACTERISTICS**

**Test Conditions:**

1. Test data was validated over the full temperature range of -40°C to +85°C, and over the supply range of 3V to 3.6V.
2. Test data represents operation at the maximum data rate of 125 Mbps using a PRBS7 test pattern (8B/10B encoding) unless otherwise stated.
3. Optical power is measured when coupled into 0.5 m of a 1 mm diameter 0.5 NA plastic fiber.

Parameter	Symbol	Minimum	Typical	Maximum	Unit
DC Supply Voltage	V <sub>CC</sub>	3.0	3.3	3.6	V
Operating Current Consumption	I <sub>CC</sub>	30	37	52	mA
Data Rate		10		125	Mbps
Data Input Capacitance	C <sub>IN</sub>			5	pF
Data Input Resistance (Single-Ended)	R <sub>IN</sub>		5		kΩ
Input Common-Mode Range	V <sub>IN-BIAS</sub>	GND+0.8		V <sub>CC</sub> -0.8	V
Input Voltage Swing	V <sub>IN-SWING</sub>	100		1200	mV
Minimum Differential Voltage Swing to Ensure Wake-Up	Wake-up Input	50			mV
Wake-Up Time Delay			5	80	μs
Optical Power OFF Delay		0.02		20	μs
Peak Wavelength	λ <sub>peak</sub>	640	660	670	nm
Spectral Bandwidth (FWHM)	Δλ	18	24	27	nm
Average Optical Power <sup>[3]</sup>	P	-10	-5.5	-1.5	dBm
Optical Rise Time (20%-80%)	t <sub>R</sub>	0.5	1.3	3.1	ns
Optical Fall Time (80%-20%)	t <sub>F</sub>	0.4	0.5	0.75	ns
Optical Modulation Amplitude (OMA)	OMA	160	590	1250	μW
Open Eye Width	T <sub>eye</sub>	6.5	7.4	7.9	ns

**SPECIFICATIONS (continued)**

**Table 4  
RECEIVER CHARACTERISTICS**

*Test Conditions:*

1. Test data was validated over the full temperature range of -40°C to +85°C, and over the supply range of 3V to 3.6V.
2. Test data represents operation at the maximum data rate of 125 Mbps using a PRBS7 test pattern (8B/10B encoding) unless otherwise stated.
3. Optical power was coupled from a minimum 0.5 m length of 1 mm diameter core and 0.5 NA step index plastic optic fiber.

Parameter	Symbol	Minimum	Typical	Maximum	Unit
DC Supply Voltage	V <sub>cc</sub>	3.0	3.3	3.6	V
Operating Current Consumption	I <sub>cc</sub>	35	43	50	mA
Output Impedance Between D and <u>D</u>	R <sub>Diff</sub>		100		Ohm
Offset Common Mode Voltage	V <sub>ocm</sub>		1.41		V
Output Differential Voltage Swing		800	1150	1400	mV
Receivable Optical Power Sensitivity			-26	-24	dBm
Maximum Allowed Optical Power				0	dBm
Rise Time (10%-90%)			1.6	3.4	ns
Fall Time (90%-10%)			1.6	3.4	ns
Signal Detect Assert/De-Assert time	T <sub>SD</sub>	0.1	0.3	0.6	us
Signal Detect Optical Assert Level	P <sub>SD-AS</sub>	-32	-27	-24	dBm
Signal Detect Optical De-Assert Level	P <sub>SD-DAS</sub>	-32	-28	-25	dBm
Signal Detect Voltage High	V <sub>SDH</sub>	2.4	3.0	3.6	V
Signal Detect Voltage Low	V <sub>SDL</sub>	0.0	0.05	0.1	V
Open Eye Width	EW	5.7	7.4	7.9	ns

**SPECIFICATIONS (continued)**

Table 5 TRANSCEIVER PIN DESCRIPTION		
Pin	Name	Symbol
TRANSMITTER		
1	EMI Shield-GND	GND
2	Signal Input TX-	TX-
3	Signal Input TX+	TX+
4	Ground Pin <sup>[1]</sup>	GND
5	DC Power Input Pin 3.3V	Vcc
6	Ground Pin <sup>[1]</sup>	GND
RECEIVER		
7	DC Power Input Pin 3.3V	Vcc
8	Ground Pin	GND
9	Signal Detect Output	SD
10	Data Output (Negative)	RD-
11	Data Output (Positive)	RD+
12	EMI Shield-GND	GND

Notes:

1. NB: both TX ground pins must be connected to the ground plane on the PCB. These pins are not connected internally.



**FIGURE 10**  
OptoLock shown with dust cap, as open for fiber, and with fiber inserted

**APPLICATION CIRCUIT**

Figure 11 is the general interface circuit. Each Ethernet PHY manufacturer recommends a termination configuration for its own design. Examples of the most commonly used PHYs are given in the Firecomms Ethernet Application Note.

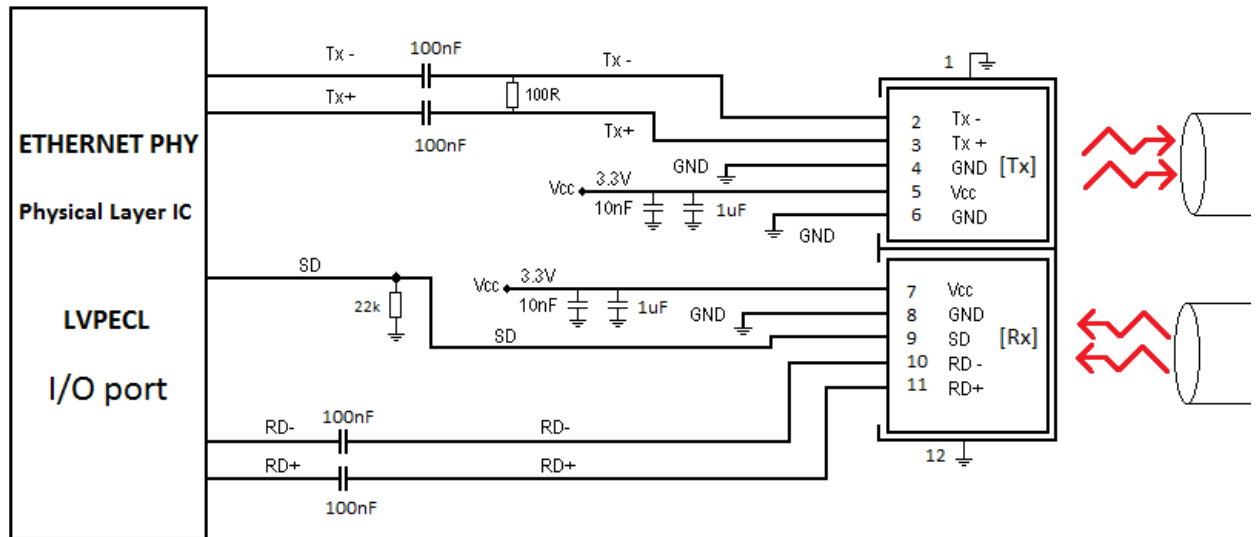
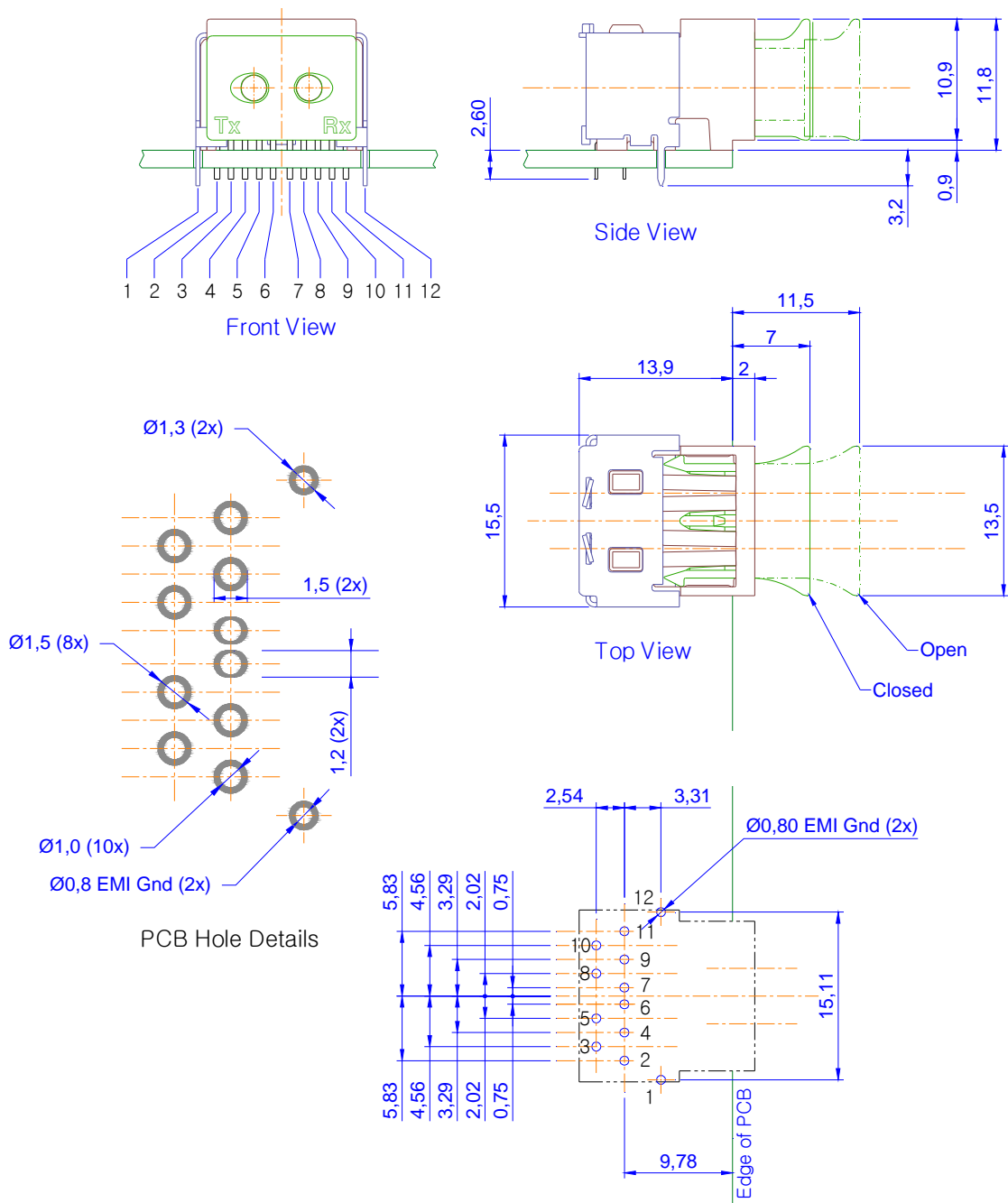

**FIGURE 11**  
Interface circuit schematic to AC couple to an Ethernet PHY

Notes:

1. The transmitter (TX) and receiver (RX) are electrically shielded from each other to prevent crosstalk. To be effective this shield must be grounded
2. Both GND pins of the TX FOT must be connected to GND (they are not connected internally).
3. Power line capacitors should be located as close as possible to the FOT's DC power PINs.
4. The data lines are impedance-matched differential pairs. The PCB layout for these tracks must comply to IEEE standards for high-speed data and impedance matching.

**MECHANICAL DATA**

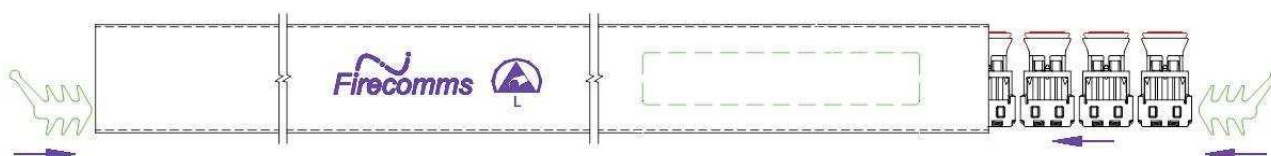

**FIGURE 12**  
**Mechanical dimensions of the OptoLock connector and PCB footprint, which is a top view. General dimensional tolerance is  $\pm 0.2$  mm.**

**PACKING INFORMATION**

Components are packed in PVC anti-static tubes in moisture barrier bags. Bags should be opened only in static-controlled locations, and standard procedures should be followed for handling moisture sensitive components.

Table 6 PACKING INFORMATION		
Components per Tube		25
	Tube Length	440 mm
	Tube Height	20 mm
	Tube Depth	31 mm
Tubes per Bag		10
Bags per Inner Carton		1
	Inner Carton Length	590 mm
	Inner Carton Height	85 mm
	Inner Carton Depth	145 mm
Weight per Inner Carton, Complete		1.8 Kg
Components per Inner Carton		250
Inner Cartons per Outer Carton		4
	Outer Carton Length	600-640 mm
	Outer Carton Height	300 mm
	Outer Carton Depth	200-285 mm
Weight per Outer Carton, Complete		8.6 Kg
Components per Outer Carton		1,000



**FIGURE 13**  
Packing tube for the Firecomms transceiver

**ORDERING INFORMATION**

Table 7 ORDERING INFORMATION		
Part Number	Name	Description
FB1M2KPR	Industrial Ethernet OptoLock Transceiver, 2.2 mm POF, Black	650 nm RCLD-Based Transceiver, Color Black, with Black Termination for Bare POF Cable 2.2 mm Diameter