

DC-50 MBd RedLink Transmitter

FT50MHNR & FT50MVNR

DATA SHEET



650 nm DC-50 MBd Fiber Optic Transmitter



FEATURES

- Visible RCLED at red wavelength (650 nm)
- Fully integrated CMOS driver IC
- Optimized for data transmission from DC-50 MBd
- Industrial temperature range -40 °C to +85 °C
- Dual 5 V and 3.3 V power rail supply options
- RoHS compliant, flame retardant (UL 94 V-0)
- TTL compatible CMOS inputs
- Compatible with Versatile Link cables and connectors

APPLICATIONS

Table 1 APPLICATIONS	
Application	Automation and Industrial Control, Serial Communications, Voltage Isolation
Standard	Serial RS232, RS485, CAN Bus, Modbus, Profibus
Distance	50 meters Step Index (SI) POF ^[1]
Speed	DC to 50 MBd

Note:

1. Depending on the installation conditions.

DESCRIPTION

The Firecomms DC-50 MBd transmitter consists of a highly reliable Resonant Cavity Light Emitting Diode (RCLED) with integrated driver IC as a visible optical transmitter housed in a miniature package to interface to plug-terminated lengths of Plastic Optic Fiber (POF). It is capable of delivering 50 MBd digital signals over fiber and operates over the temperature range of -40 °C to +85 °C.

The FT50MHNR & FT50MVNR contain a red RCLED with fully integrated precision driver IC, designed to provide a communication link over POF. The RCLED in this transceiver is a highly reliable visible incoherent light source requiring low operating current. The use of an intrinsically eye-safe, visible light simplifies link set-up and testing.

SPECIFICATIONS

Table 2
DC-50 MBd TRANSMITTER ABSOLUTE MAXIMUM RATINGS

These are the absolute maximum ratings at or beyond which the FOT can be expected to be damaged.

Notes:

1. 260 °C for 10 sec, one time only, at least 2.2 mm away from lead root.

Parameter	Symbol	Minimum	Maximum	Unit
Storage Temperature	T _{stg}	-40	+85	°C
Operating Temperature ^[1]	T _{op}	-40	+85	°C
Soldering Temperature ^[1]	T _{sld}		+260 ^[1]	°C
Supply Voltage (TX)	V _{cc}	-0.5	5.5	V
TX Input Voltage (Data in)	V _{IN}	-0.5	5.5	V
Storage Compliance	MSL		2a	J-STD-020D

Table 3
TRANSMITTER ELECTRICAL AND OPTICAL CHARACTERISTICS

Test Conditions:

1. Test data was validated over the full temperature range of -40 °C to +85 °C, and over the full drive current range. Typical data are at 25 °C, with data running to a 50% duty cycle and standard TTL or LVTTTL input (1.4 V logic threshold to 50% optical threshold).
2. Optical power measured at the end of 0.5 meters of 1 mm diameter plastic with a large area detector.

Parameter	Symbol	Min	Typical	Max	Unit	Test Condition
Supply Current	I _{cc}		40		mA	
TX Wake Up Delay	t _{on}		3		µs	[2]
Input Voltage - Low	V _{IL}	-0.3		0.8	V	[1]
Input Voltage - High	V _{IH}	2.0		V _{cc} +0.25	V	[1]
Data Input Capacitance	C _{in}		7		pF	
Data Input Resistance	R _{in}		100		kΩ	
Optical Power High (OPH)	P _H	-5.5		+1.5	dBm	Input Voltage High ^{[1],[2]}
Optical Power Low (OPL)	P _L			-40	dBm	Input Voltage Low ^{[1],[2]}
Optical Wavelength	λ	640	650	670	nm	
Spectral Bandwidth (FWHM)	Δλ			30	nm	
Optical Rise Time (80%-20%)	t _r		3	6	ns	
Optical Fall Time (80%-20%)	t _f		3	5	ns	
TX Pulse Width Distortion	PWD	-2.0	0.5	+2.0	ns	[1]

FT50MHNR & FT50MVNR Revision B

Firecomms assumes no responsibility for inaccuracies or omissions in the information contained in this document. Specifications are subject to change without notice. No patent rights are granted to any of the circuits described herein.

SPECIFICATIONS (continued)

Table 4 TRANSMITTER PIN DESCRIPTION		
Pin	Name	Symbol
1	Line Voltage	Vcc
2	No Pin Present	NP
3	GROUND	GND
4	Data Input (TTL)	D+
5	Retaining Pin ^[5]	GND
8	Retaining Pin ^[5]	GND

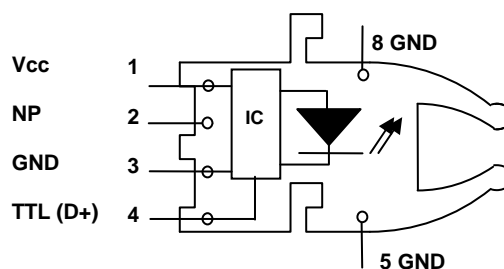

FIGURE 1
RedLink 50 Mbd transmitter PCB footprint, top-view

APPLICATION CIRCUIT

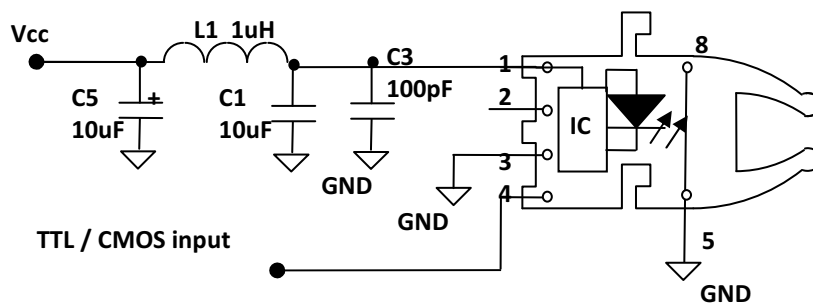

FIGURE 2
Recommended transmitter application circuit

MECHANICAL DATA

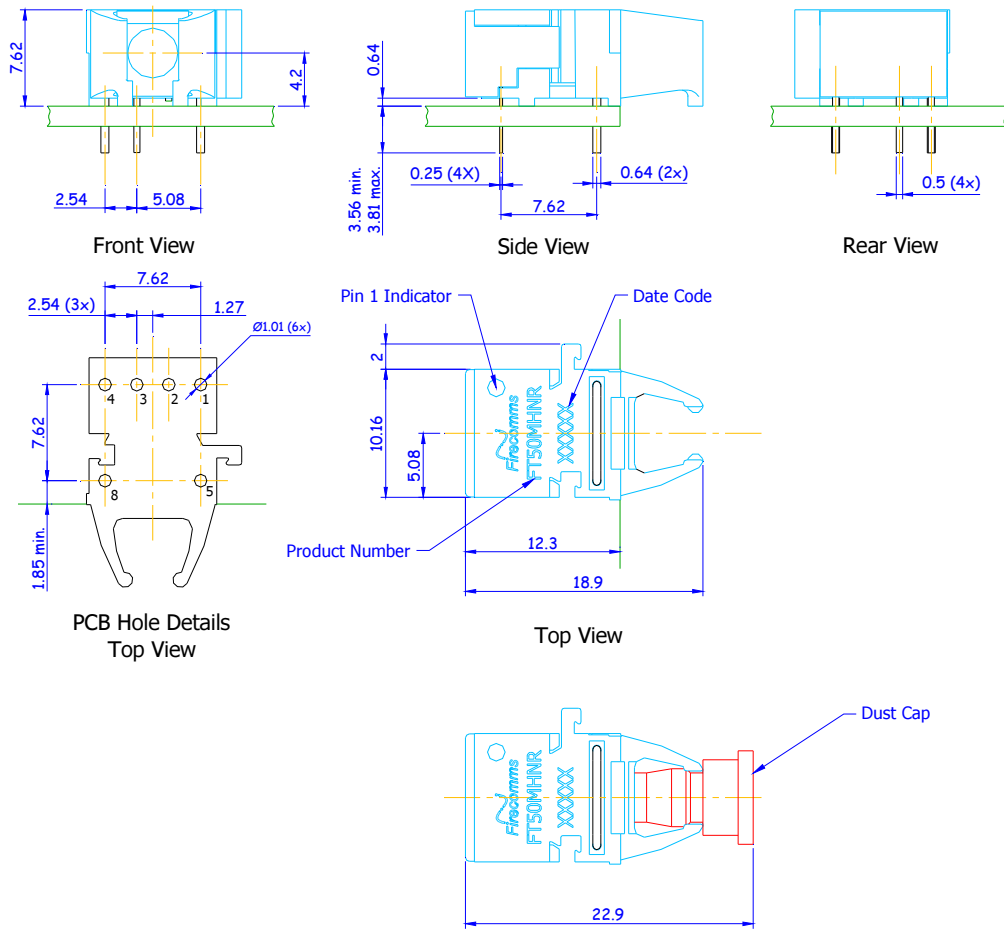

FIGURE 3
Mechanical dimensions of the Horizontal RedLink 50 MBd Transmitter showing its three-pin configuration.
General dimensional tolerance is ±0.2 mm.

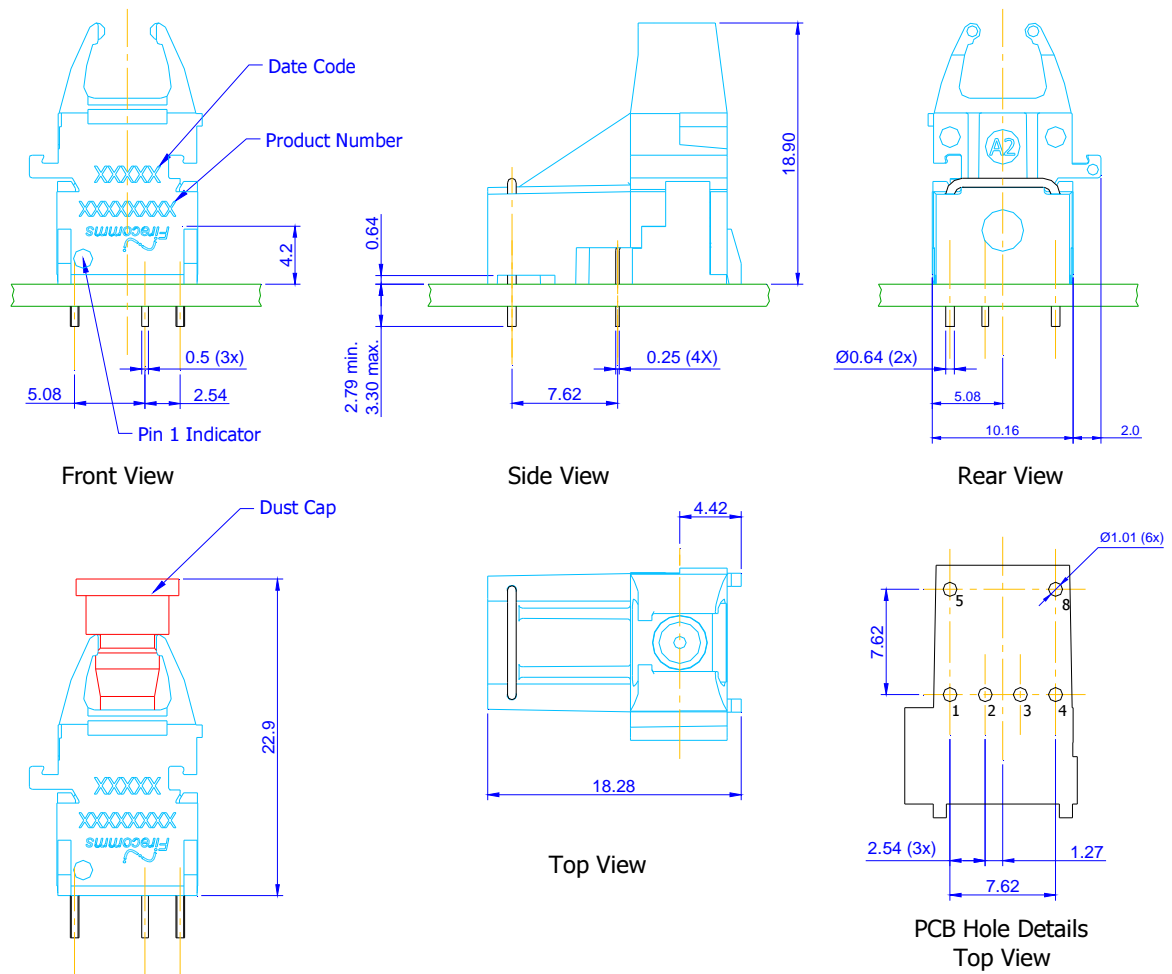

FIGURE 4
Mechanical dimensions of the Vertical RedLink 50 MBd Transmitter showing its three-pin configuration.
General dimensional tolerance is ± 0.2 mm.

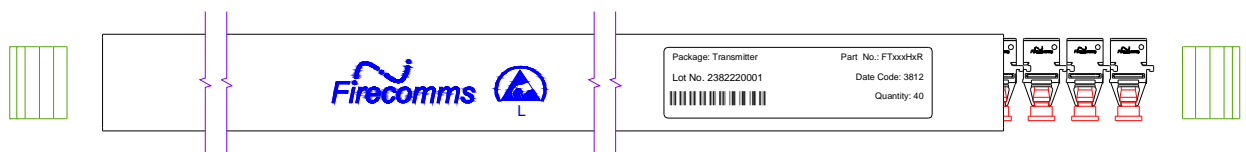

FIGURE 5
Packing tube for the Firecomms 50 MBd transmitter

PACKING INFORMATION

Components are packed in PVC anti-static tubes in moisture barrier bags. Bags should be opened only in static-controlled locations, and standard procedures should be followed for handling moisture sensitive components.

Table 7 PACKING INFORMATION			
		Horizontal	Vertical
Components per Tube		40	40
	Tube Length	515 mm	515 mm
	Tube Height	16.2 mm	21.0 mm
	Tube Depth	26.9 mm	30.8 mm
Tubes per Bag		5	5
Bags per Inner Carton		1	1
	Inner Carton Length	630 mm	630 mm
	Inner Carton Height	70 mm	70 mm
	Inner Carton Depth	105 mm	105 mm
Weight per Inner Carton, Complete		0.48 Kg	0.66 Kg
Components per Inner Carton		200	200
Inner Cartons per Outer Carton		10	10
	Outer Carton Length	650 mm	650 mm
	Outer Carton Height	235 mm	235 mm
	Outer Carton Depth	376 mm	376 mm
Weight per Outer Carton, Complete		5.28 Kg	6.98 Kg
Components per Outer Carton		2,000	2,000

ORDERING INFORMATION

Table 6 ORDERING INFORMATION		
Part Number	Name	Description
FT50MHNR	RedLink 50 MBd Transmitter, Horizontal	RedLink 650 nm, Horizontal, DC – 50 MBd RCLED-Based Transmitter, Gray Casing
FT50MVNR	RedLink 50 MBd Transmitter, Vertical	RedLink 650 nm, Vertical, DC – 50 MBd RCLED-Based Transmitter, Gray Casing