



650 nm DC-10 MBd Low Current Fiber Optic Transmitter

FEATURES

- Visible RCLED at red wavelength (660 nm)
- Optimized for data transmission from DC to 10 MBd with low current consumption
- Ideal for use with Step Index (SI) Plastic Optical Fiber (POF)
- Industrial temperature range -40°C to +85°C
- RoHS compliant
- Flame retardant (UL 94 V-0) connector housings
- Low pulse width distortion
- Compatible with Versatile Link cables and connectors

APPLICATIONS

Table 1	
Application	Automation and Industrial Control, Low-Speed Serial Communications, Voltage Isolation
Standard	Serial RS232, RS485, CAN Bus, Modbus, Profibus, Sercos
Distance	50 meters Step Index POF ^[1]
Speed	DC to 10 MBd

Note:

1. Depending on the installation conditions.

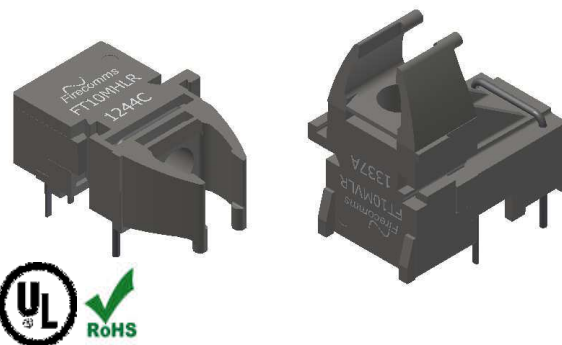

DESCRIPTION

The Firecomms DC to 10 MBd low current RedLink® transmitter is a highly reliable Resonant Cavity Light Emitting Diode (RCLED) which operates as a visible optical source generating red 650 nm light at data rates from burst mode DC to a maximum of 10 MBd of continuous digital data. The RCLED is encapsulated in a lensed clear molded plastic package for optimum coupling to Plastic Optical Fiber (POF). It operates over the industrial temperature range of -40°C to +85°C.

The 10 MBd transmitter produces higher optical power for the same input current relative to the standard Firecomms 10 MBd device (FT10MHNR). This allows a lower overall current consumption when used in an existing link design.

The transmitter is assembled in a gray non-conducting plastic horizontal-mounted housing requiring low operating current. The use of the eye-safe, visible light simplifies link set-up and testing.

For optimum link performance Firecomms recommends using this transmitter in combination with the standard 10 MBd receiver, FR10MHIR, for optical to electrical conversion. Typical applications use 10 MBd over POF in industrial automation serial bus protocols.

SPECIFICATIONS, General

Table 2
DC-10 MBd LOW CURRENT TRANSMITTER ABSOLUTE MAXIMUM RATINGS

These are the absolute maximum ratings at or beyond which the FOT can be expected to be damaged.

Notes:

1. 260°C for 10 seconds, one time only, at least 2.2 mm away from lead root.
2. When peak forward current exceeds 30 mA, the duty cycle must maintain a pulse width (PW) less than 1 μs and average forward current less than or equal to 30 mA. [$30 \text{ mA} \leq I_{\text{FPK}} \leq 45 \text{ mA} \leftrightarrow I_{\text{FAVG}} \leq 30 \text{ mA AND PW} \leq 1 \mu\text{s}$]

Parameter	Symbol	Minimum	Maximum	Unit
Storage Temperature	T _{stg}	-40	+85	°C
Operating Temperature ^[1]	T _{op}	-40	+85	°C
Soldering Temperature ^[1]	T _{slid}		+260 ^[1]	°C
TX Reverse Input Voltage	V _R		3	V
TX Peak Forward Input Current ^[2]	I _{FPK}		45	mA
Average Forward Input Current ^[2]	I _{FAVG}		30	mA
Storage Compliance	MSL		2a	J-STD-020D

Table 3
DC-10 MBd LOW CURRENT TRANSMITTER REGULATORY COMPLIANCE

Parameter	Symbol	Standard	Level
Electrostatic Discharge, Human Body Model (contact ESD)	HBM	Mil-STD-883	Level 2 (4 kV)
Radiated Emissions Immunity	Vm ⁻¹	IEC 61000-4-3	15 Vm ⁻¹
UL Certification	UL	94 V-0 material	Files No. E362227
Storage Compliance	MSL	J-STD-020D	2a (4 week floor life)
Restriction of Hazardous Substances Directive	RoHS	Directive 2002/95/EC	Certified compliant
Eye Safety		IEC 60825-1	LED Class 1

SPECIFICATIONS, Handling

Firecomms' 10 MBd RedLink devices are gray. They are auto-insertable and are tested for handling in static controlled assembly processes (HBM and CDM). Cleaning, degreasing and post solder washing should be carried out using standard solutions compatible with both plastics and the environment. For example, recommended solutions for degreasing are alcohols (methyl, isopropyl and isobutyl). In the soldering process, non-halogenated water soluble fluxes are recommended. RedLink products are not suitable for use in reflow solder processes (infrared/vapor-phase reflow). The dust plug should be kept in place during soldering, washing and drying processes to avoid contamination of the active optical area of each connector.

SPECIFICATIONS, Transmitter

Table 4
TRANSMITTER ELECTRICAL AND OPTICAL CHARACTERISTICS

Test Conditions:

1. Test data was validated over the full temperature range of -40°C to $+85^{\circ}\text{C}$, and over the full drive current range.
2. Optical power for POF is measured when coupled into 0.5 m of a 1 mm diameter 0.5 NA POF and a large area detector.
3. As measured in the given application circuit (inverting) as shown in Figure 5 with 50 cm of 0.5 NA POF.
4. Emission Wavelength (centroid) $\lambda_c = \sum P_i \lambda_i / \sum P_i$. (Ref: EIA/TIA std. FOTP-127/6.1, 1991)
5. Spectral Width Root Mean Squared (RMS) $\lambda_{\text{RMS}} = (\sum P_i (\lambda_c - \lambda_i)^2 / \sum P_i)^{1/2}$. (Ref: EIA/TIA std. FOTP-127/6.3, 1991)

Parameter	Symbol	Min	Typical	Max	Unit	Test Condition
Output Power	P	-3	+2	+4	dBm	1 mm POF, $I_{\text{FDC}} = 30 \text{ mA}$
		-9	-3	-1	dBm	1 mm POF, $I_{\text{FDC}} = 10 \text{ mA}$
		-11	-5	-3	dBm	1 mm POF, $I_{\text{FDC}} = 5 \text{ mA}$
		-14	-8	-6	dBm	1 mm POF, $I_{\text{FDC}} = 3 \text{ mA}$
Emission Wavelength (centroid) ^[4]	λ_c	640	660	680	nm	$I_{\text{FDC}} = 30 \text{ mA}$
Spectral Width (RMS) ^[5]	λ_{RMS}		11	20	nm	$I_{\text{FDC}} = 30 \text{ mA}$
Forward Voltage	V_F	1.4	1.95	2.4	V	$I_{\text{FDC}} = 30 \text{ mA}$
Forward Voltage Temperature Coefficient	$\Delta V_F / \Delta T$		-3.5		$\text{mV}/^{\circ}\text{C}$	$I_{\text{FDC}} = 30 \text{ mA}$
Reverse Input Breakdown Voltage	V_{BR}	20			V	$I_{\text{FDC}} = -1 \mu\text{A}$
Diode Capacitance	C_o		11		pF	$V = 0 \text{ V}$
Data Rate		DC		10	MBd	
Optical Rise Time (20%-80%)	t_r		5	7	ns	$I_{\text{FAVG}} = 15 \text{ mA}^{[3]}$
Optical Fall Time (80%-20%)	t_f		7	9	ns	$I_{\text{FAVG}} = 15 \text{ mA}^{[3]}$
Propagation Delay Low-to-High (Electrical-to-Optical)	PropDly_LtoH (EL/OP)	18	22	28	ns	$I_{\text{FAVG}} = 15 \text{ mA}^{[3]}$
Propagation Delay High-to-Low (Electrical-to-Optical)	PropDly_HtoL (EL/OP)	16	24	36	ns	$I_{\text{FAVG}} = 15 \text{ mA}^{[3]}$
Pulse Width Distortion	PWD	-2	2	8	ns	$I_{\text{FAVG}} = 15 \text{ mA}^{[3]}$

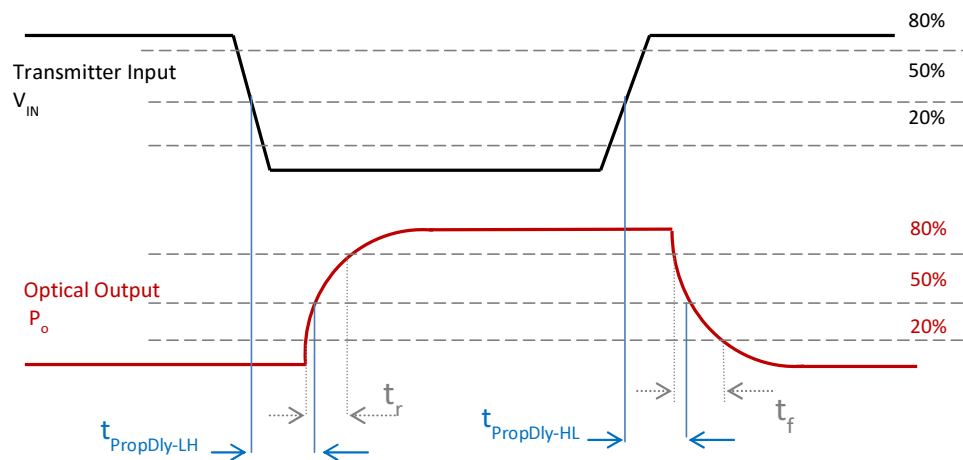

FIGURE 1
Transmitter propagation delay and rise/fall time definitions.

SPECIFICATIONS, Transmitter (continued)

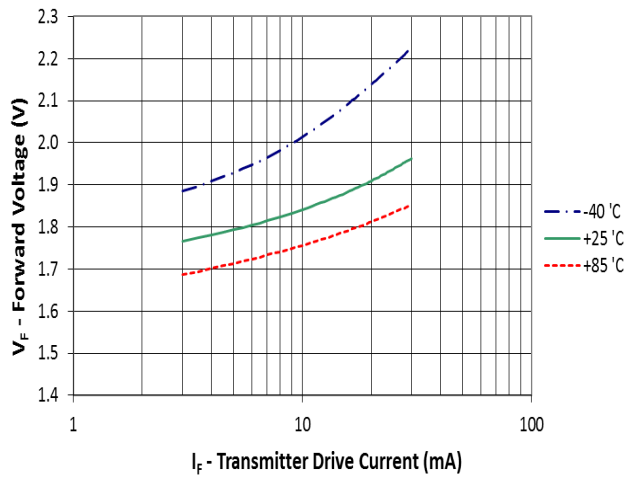

FIGURE 2
Typical forward voltage (VF) vs. drive current (IF,DC).

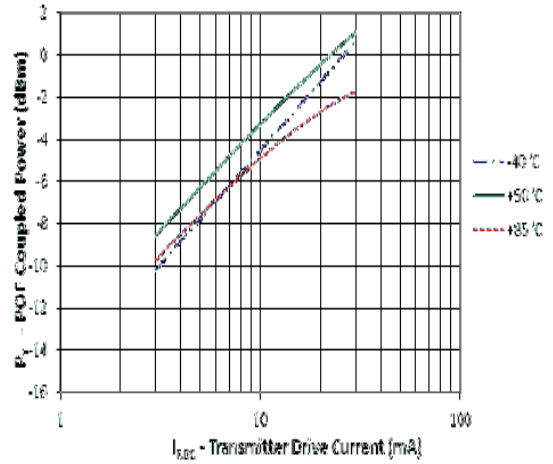

FIGURE 3
Typical normalized optical power vs. drive current.

Table 5 TRANSMITTER PIN DESCRIPTION		
Pin	Name	Symbol
1	RCLED ANODE	TX+
2	RCLED CATHODE	TX-
3	NC	GND
4	NC	GND
5	Retaining Pin	GND
8	Retaining Pin	GND

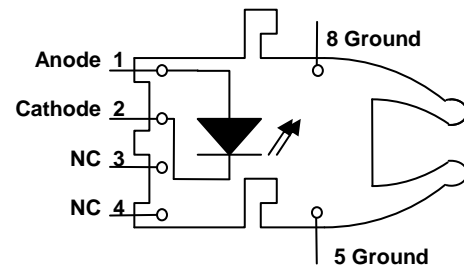

FIGURE 4
RedLink low current transmitter PCB footprint, top-view.

APPLICATION CIRCUIT

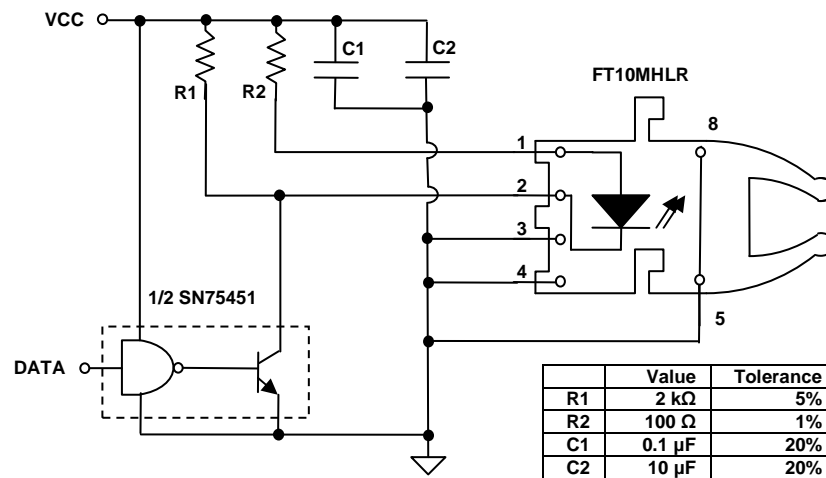

FIGURE 5
Recommended low current transmitter (inverting) application circuit. I_{F,ON} = 30 mA nominal at +25°C.

MECHANICAL DATA, Horizontal

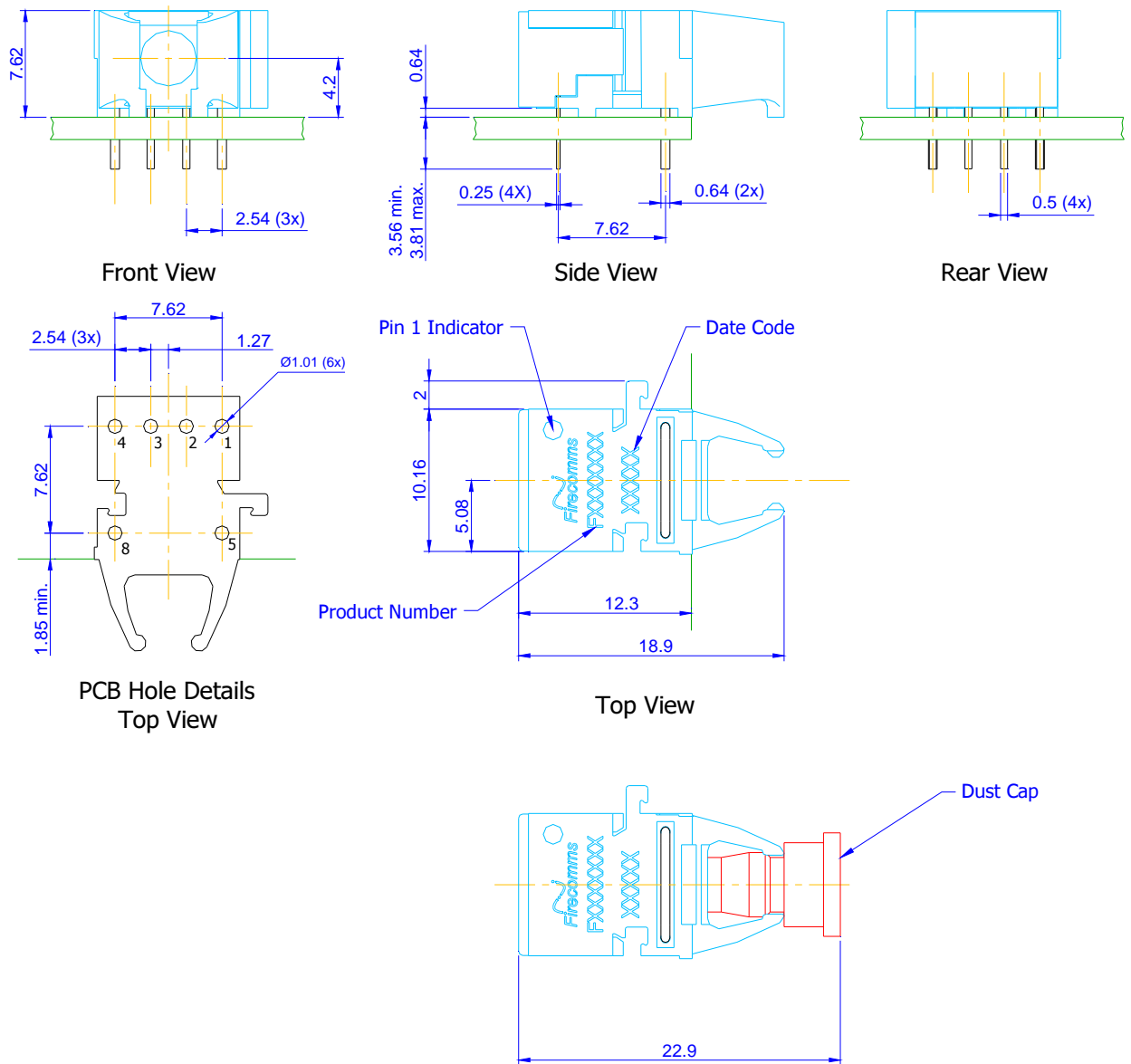

FIGURE 6
Mechanical dimensions of the Horizontal 10 Mbd Low Current RedLink connector and PCB footprint, which is a top view. General dimensional tolerance is ± 0.2 mm.

MECHANICAL DATA, Vertical

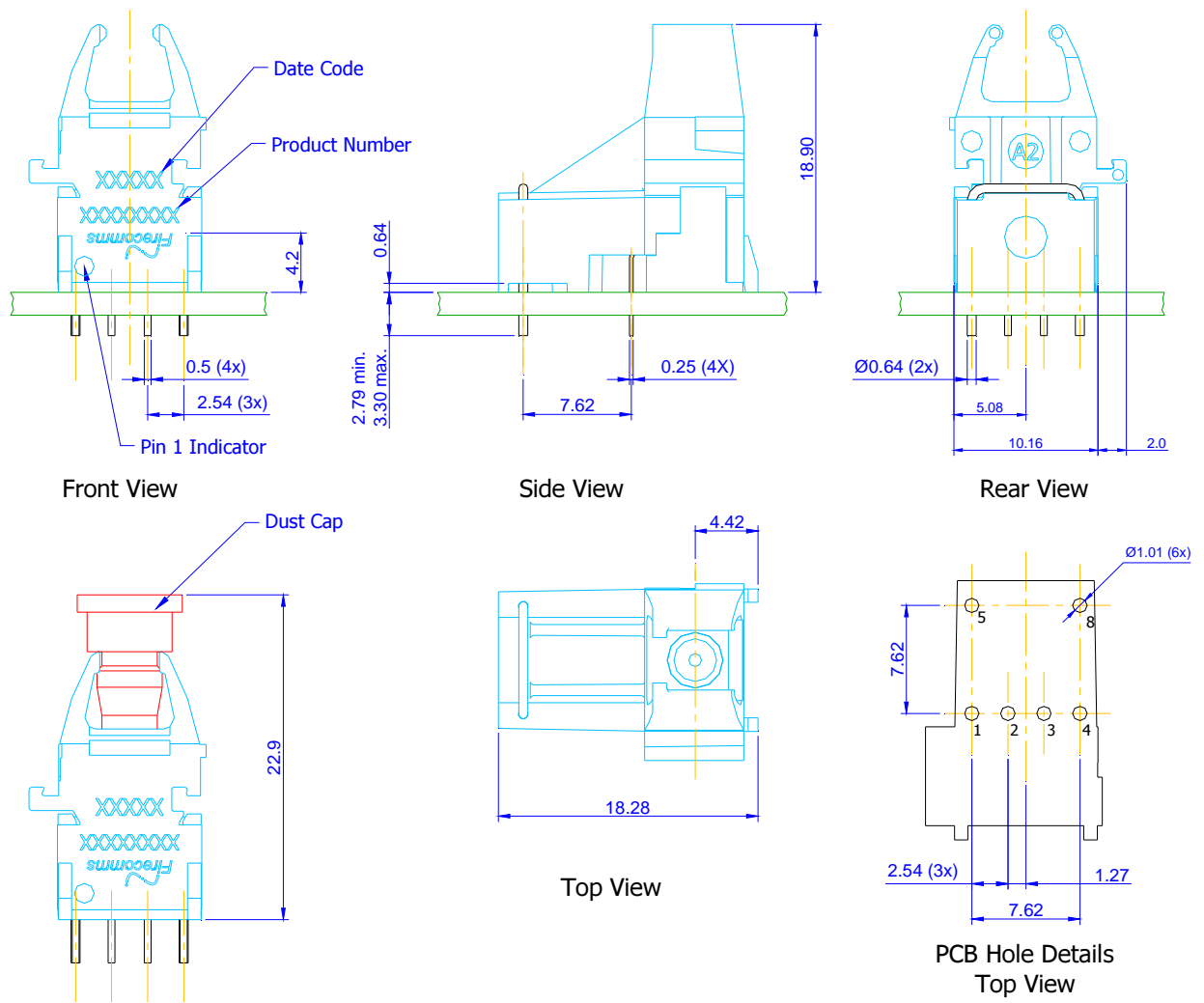

FIGURE 7
 Mechanical dimensions of the Vertical 10 Mbd Low Current RedLink connector and PCB footprint, which is a top view. General dimensional tolerance is ± 0.2 mm.

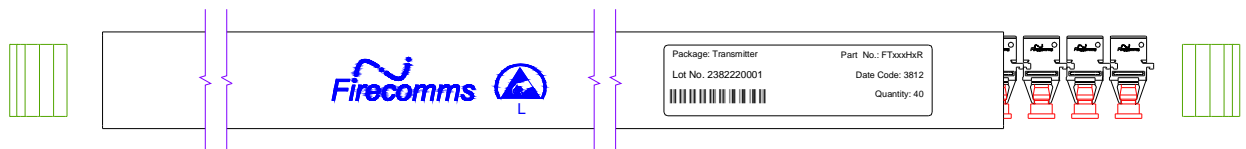

FIGURE 8
 Packing tube for the Firecomms 10 MBd transmitter.

PACKING INFORMATION

Components are packed in PVC anti-static tubes in moisture barrier bags. Bags should be opened only in static-controlled locations, and standard procedures should be followed for handling moisture sensitive components.

Table 6 PACKING INFORMATION		
	Horizontal	Vertical
Components per Tube	40	40
Tube Length	515 mm	515 mm
Tube Height	16.2 mm	21.0 mm
Tube Depth	26.9 mm	30.8 mm
Tubes per Bag	5	5
Bags per Inner Carton	1	1
Inner Carton Length	630 mm	630 mm
Inner Carton Height	70 mm	70 mm
Inner Carton Depth	105 mm	105 mm
Weight per Inner Carton, Complete	0.48 Kg	0.66 Kg
Components per Inner Carton	200	200
Inner Cartons per Outer Carton	10	10
Outer Carton Length	650 mm	650 mm
Outer Carton Height	235 mm	235 mm
Outer Carton Depth	376 mm	376 mm
Weight per Outer Carton, Complete	5.28 Kg	6.98 Kg
Components per Outer Carton	2,000	2,000

ORDERING INFORMATION

Table 7 ORDERING INFORMATION		
Part Number	Name	Description
FT10MHLR	RedLink 10 MBd Low Current Transmitter, Horizontal	RedLink 650 nm, DC-10 MBd RCLED-Based Low Current Transmitter, Gray Housing, Horizontal
FT10MVLR	RedLink 10 MBd Low Current Transmitter, Vertical	RedLink 650 nm, DC-10 MBd RCLED-Based Low Current Transmitter, Gray Housing, Vertical