



650 nm DC-10 MBd RedLink® Fiber Optic Transmitter and Receiver



FEATURES

- Ideal for use with POF and PCS fiber
- Optimized for data transmission from DC to 10 MBd
- Industrial temperature range: -40°C to +85°C
- RoHS and UL compliant
- Flame retardant (UL 94 V-0) connector housings.
- RCLED transmitter with visible red light (650 nm wavelength)
- Fully integrated IC receiver with dual differential photo-diodes and integrated TIA and TTL output
- 5V TTL/CMOS compatible I/O for ease of design
- Low pulse width distortion
- Compatible with Versatile Link cables and connectors

APPLICATIONS

Table 1 APPLICATIONS	
Application	Automation and Industrial Control, Low-Speed Serial Communications, Voltage Isolation
Standard	Serial RS232, RS485, CAN Bus, Modbus, Profibus, Sercos
Distance	50 meters Step Index (SI) POF ^[1] 300 meters with 200µm PCS fiber ^[1]
Speed	DC to 10 MBd

Note:

1. Depending on the installation conditions.

DESCRIPTION

The Firecomms DC to 10 MBd RedLink® transceiver pair consists of a highly reliable Resonant Cavity Light Emitting Diode (RCLED) as a visible optical transmitter and an integrated receiver within a miniature package to interface to plug-terminated lengths of Plastic Optic Fiber (POF) or 200 µm Plastic Clad Silica (PCS) fiber. The device is capable of delivering digital signals as burst mode or continuous data from DC to 10 MBd over POF/PCS and operates over the industrial temperature range of -40°C to +85°C. It is available in horizontal and vertical package styles.

The 10 MBd transmitter has a gray non-conducting plastic housing containing a clear plastic encapsulated light source. The light source is a large-current aperture (150 µm diameter) red (650 nm) eye-safe RCLED based on InGaP/InGaAlP/GaAs technology. The RCLED operates over a wide range of drive current that can be adjusted using a serial resistor to minimize current consumption for a given fiber distance. The RCLED transmitter has been designed to achieve improved electrical-to-optical efficiency at low drive currents.

The 10 MBd receiver comprises of a black non-conducting plastic housing containing a clear plastic package that encapsulates a monolithic receiver IC. The fully integrated IC uses dual photo-diodes operating as a low-noise receiver for optical-to-electrical conversion. It has integrated pulse width distortion minimization circuitry for reliable data transmission. The receiver features a push-pull 5V TTL compatible CMOS output. The receiver is typically used in industrial automation and serial bus protocols.

SPECIFICATIONS, General

Table 2
DC-10 MBd TRANSMITTER AND RECEIVER ABSOLUTE MAXIMUM RATINGS

These are the absolute maximum ratings at or beyond which the FOT can be expected to be damaged.

Notes:

1. 260°C for 10 seconds, one time only, at least 2.2 mm away from lead root.
2. When peak forward current exceeds 60 mA then the duty cycle must maintain a pulse width (PW) less than 1 μ s and average forward current less than or equal to 60 mA. [60 mA \leq I_{FPK} \leq 1000 mA \leftrightarrow I_{FAVG} \leq 60 mA AND PW \leq 1 μ s]

Parameter	Symbol	Minimum	Maximum	Unit
Storage Temperature	T _{stg}	-40	+85	°C
Operating Temperature ^[1]	T _{op}	-40	+85	°C
Soldering Temperature ^[1]	T _{slid}		+260 ^[1]	°C
TX Reverse Input Voltage	V _R		-10	V
TX Forward Input Current ^[2]	I _{FDC}		80	mA
TX Peak Forward Input Current ^[2]	I _{FPK}		1000	mA
Average Forward Input Current ^[2]	I _{FAVG}		60	mA
RX Supply Voltage	V _{CC}	-0.5	+5.5	V
RX Output Current	I _{OAVG}	-16	+16	mA

Table 3
DC-10 MBd TRANSMITTER AND RECEIVER REGULATORY COMPLIANCE

Parameter	Symbol	Standard	Level
Electrostatic Discharge, Human Body Model (contact ESD)	HBM	Mil-STD-883	Level 2 (4 kV)
Radiated Emissions Immunity	Vm ⁻¹	IEC 61000-4-3	15 Vm ⁻¹
UL Certification	UL	94 V-0 material	Files No. E362227
Storage Compliance	MSL	J-STD-020D	2a (4 week floor life)
Restriction of Hazardous Substances Directive	RoHS	Directive 2002/95/EC	Certified compliant
Eye Safety		IEC 60825-1	LED Class 1

SPECIFICATIONS, Handling

Firecomms' 10 MBd RedLink devices are color coded: transmitters are gray and receivers are black. They are auto-insertable. They are tested for handling in static-controlled assembly processes (HBM and CDM). Cleaning, degreasing and post solder washing should be carried out using standard solutions compatible with both plastics and the environment. For example, recommended solutions for degreasing are alcohols (methyl, isopropyl and isobutyl). In the soldering process, non-halogenated water soluble fluxes are recommended. RedLink products are not suitable for use in reflow solder processes (infrared/vapor-phase reflow). The dust plug should be kept in place during soldering, washing and drying processes to avoid contamination of the active optical area of each connector.

SPECIFICATIONS, Transmitter

**Table 4
TRANSMITTER ELECTRICAL AND OPTICAL CHARACTERISTICS**

Test Conditions:

1. Test data was validated over the full temperature range of -40°C to +85°C, and over the full drive current range.
2. Optical power for POF is measured when coupled into 0.5 m of a 1 mm diameter 0.5 NA POF and a large area detector.
3. Optical power for PCS is measured when coupled into 0.5 m of a 200 μm diameter PCS and a large area detector.
4. As measured in the given application circuit (inverting) shown in Figure 9 over 50 cm of 0.5 NA POF.
5. Emission Wavelength (centroid) $\lambda_c = \sum_i P_i \cdot \lambda_i / \sum_i P_i$. (Ref: EIA/TIA std. FOTP-127/6.1, 1991)
6. Spectral Width Root Mean Squared (RMS) $\lambda_{RMS} = (\sum_i P_i (\lambda_c - \lambda_i)^2 / \sum_i P_i)^{1/2}$ (ref: EIA/TIA std. FOTP-127/6.3, 1991).

Parameter	Symbol	Min	Typical	Max	Unit	Test Condition
Output Optical Power	P_o	-7.2	-3.5	+1.3	dBm	1 mm POF, $I_{FDC} = 60$ mA
		-16.8	-9.0	-0.7	dBm	1 mm POF, $I_{FDC} = 20$ mA
		-17.3	-12.5	-7.2	dBm	200 μm PCS, $I_{FDC} = 60$ mA
Emission Wavelength (centroid) [5]	λ_c	635	650	665	nm	$I_{FDC} = 30$ mA
Spectral Width (RMS) [6]	λ_{RMS}		11	16	nm	$I_{FDC} = 30$ mA
Forward Voltage	V_F	1.8	2.1	2.65	V	$I_{FDC} = 60$ mA
Forward Voltage Temperature Coefficient	$\Delta V_F / \Delta T$		-3.3		mV/°C	$I_{FDC} = 60$ mA
Reverse Input Breakdown Voltage	V_{BR}	10			V	$I_{FDC} = -1$ μA
Diode Capacitance	C_o		11		pF	V = 0 V
TX Numerical Aperture	NA		0.5			$I_{FDC} = 60$ mA
Data Rate		DC		10	MBd	Min UI = 100 ns, Max f = 5 MHz
Optical Rise Time (20%-80%)	t_r		6	9	ns	$I_{FAVG} = 30$ mA [4], see fig.1
Optical Fall Time (80%-20%)	t_f		8	11	ns	$I_{FAVG} = 30$ mA [4], see fig.1
Propagation Delay Low-to-High (ELEC – OPTO)	$t_{PropDly_LH}$	20	23	30	ns	$I_{FAVG} = 30$ mA [4], see fig.1
Propagation Delay High-to-Low (ELEC – OPTO)	$t_{PropDly_HL}$	18	25	36	ns	$I_{FAVG} = 30$ mA [4], see fig.1
Pulse Width Distortion	PWD	-4	2	8	ns	$I_{FAVG} = 30$ mA [4], see fig.1

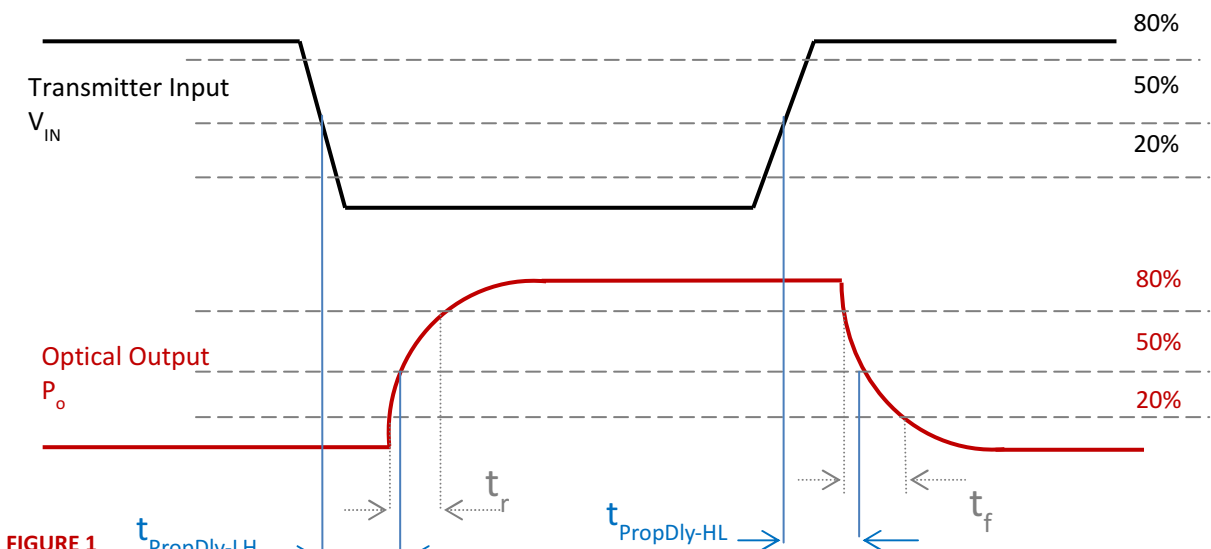

FIGURE 1 $t_{PropDly-LH}$ t_r $t_{PropDly-HL}$ t_f
Definition of Transmitter Propagation Delay, rise and fall times.

SPECIFICATIONS, Transmitter (continued)

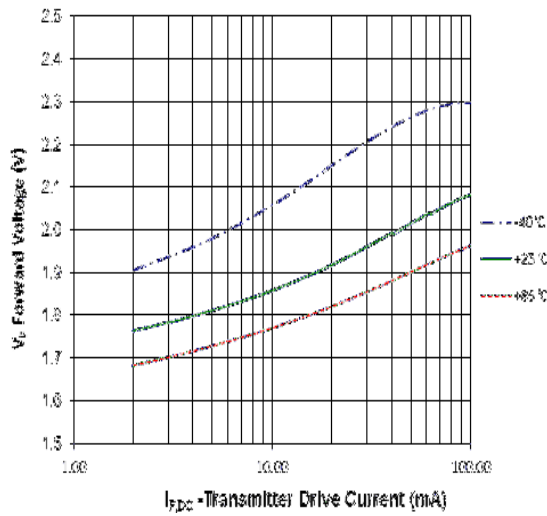

FIGURE 2
Typical forward voltage (VF) vs. drive current (IF,DC).

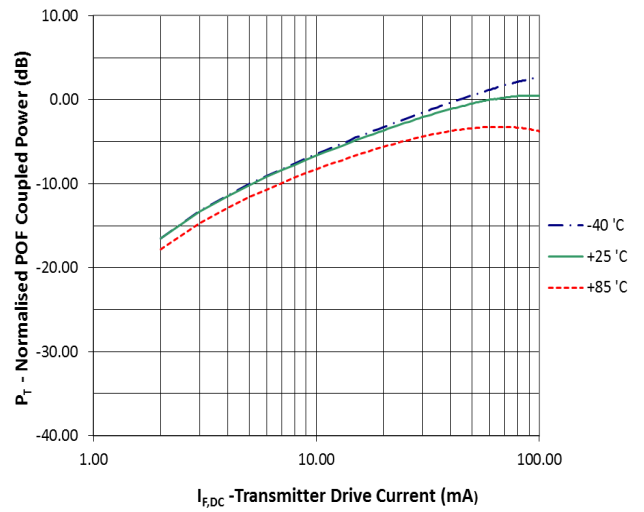

FIGURE 3
Typical normalized optical power vs. drive current.

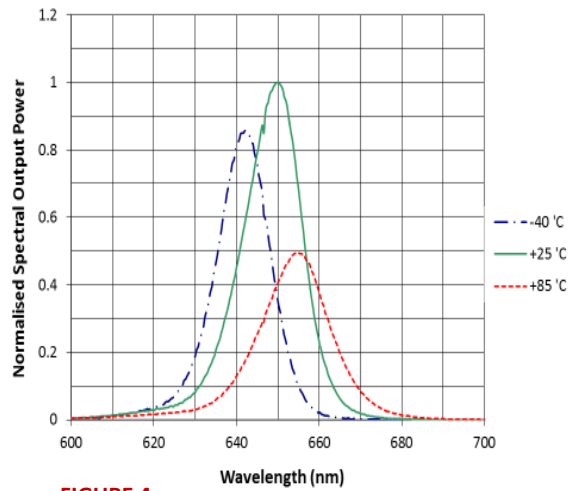

FIGURE 4
Typical normalized optical spectra.

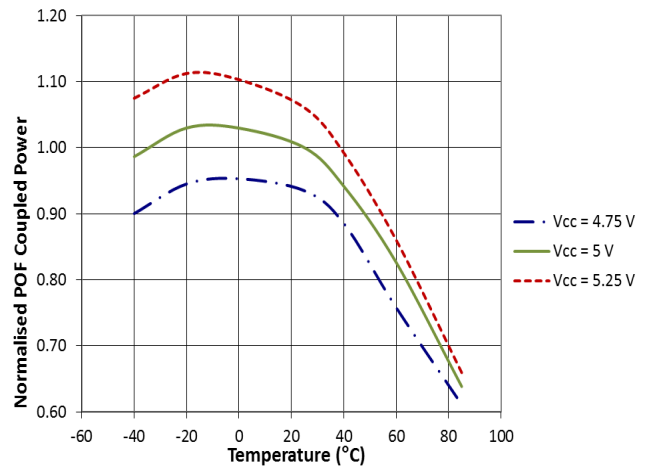

FIGURE 5
Typical normalized optical power vs. temperature (in recommended drive circuit).

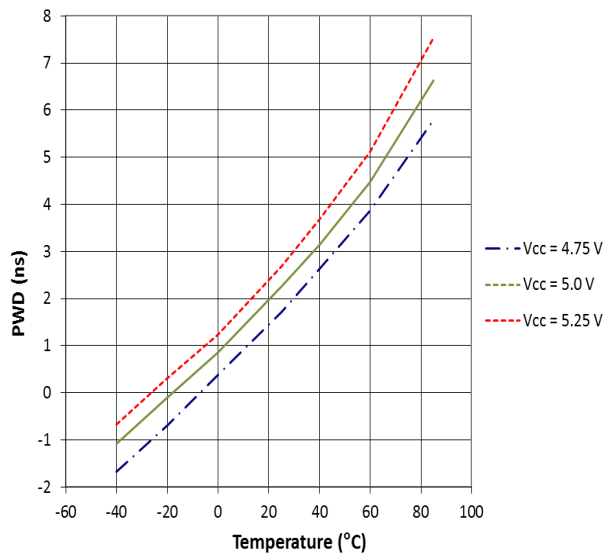

FIGURE 6
Typical optical pulse width distortion vs. temperature and power supply voltage (in recommended drive circuit).

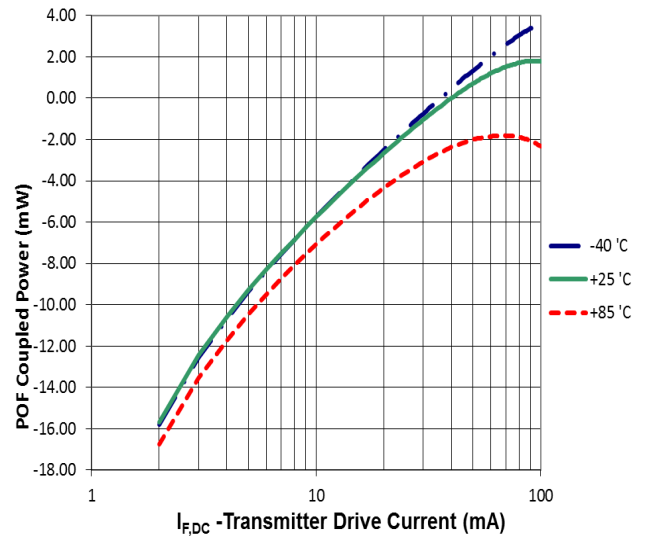

FIGURE 7
Typical POF coupled optical power vs. drive current.

SPECIFICATIONS, Transmitter (continued)

Table 5 TRANSMITTER PIN DESCRIPTION		
Pin	Name	Symbol
1	RCLED ANODE	TX+
2	RCLED CATHODE	TX-
3	Ground Pin ^[1]	GND
4	Ground Pin ^[1]	GND
5	Retaining Pin	GND
8	Retaining Pin	GND

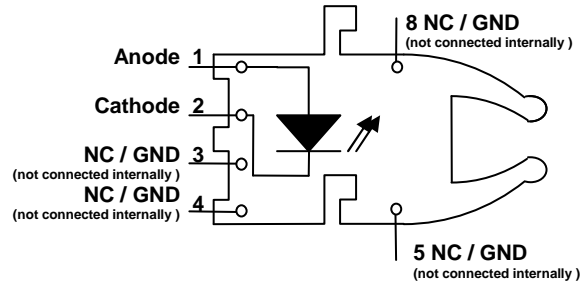

FIGURE 8
RedLink pin numbering.

Notes:

- NB: both TX ground pins must be connected to the ground plane on the PCB. These pins are not connected internally.

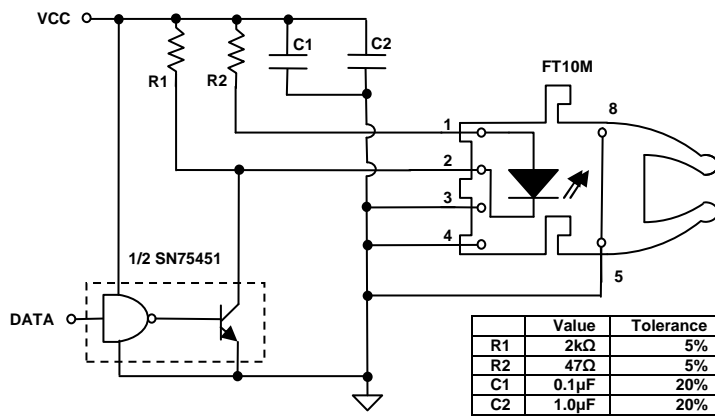

FIGURE 9
Inverting transmitter reference circuit for the 10 MBd transmitter; for temperature range 0°C to +70°C, use SN75451B as the driver IC. For temperature range -40°C to +85°C, use SN55451B as the driver. $I_{F,ON} = 60 \text{ mA}$ nominal at +25°C.

SPECIFICATIONS, Receiver

Table 6
RECEIVER ELECTRICAL AND OPTICAL CHARACTERISTICS

Test Conditions:

1. Test data was validated over the full temperature range of -40°C to +85°C, and over the full supply rail voltage of 4.5 V to 5.5 V. Data referred to as typical are rated at +25°C and $V_{CC} = 5.0$ V.
2. Input power levels are for peak (not average) optical input levels. For 50% duty cycle data, peak optical power is twice the average optical power.
3. Receiver overdrive (PRL, max) is specified as the limit where |PWD| will not exceed 14 ns. The receiver will be in the correct state (logic "0") for optical powers above PRL, max. However, it may not meet a 14% symbol period PWD if the overdrive limit is exceeded.
4. Estimated value measured from junction to PC board solder joint for horizontal mount package.
5. Pins 5 and 8 are used for mounting and retaining purposes. It is required that pins 5 and 8 be connected to ground.
6. In recommended receiver circuit, with an optical signal from the recommended transmitter circuit.
7. Pin 4 is electrically isolated internally. Pin 4 may be externally connected to pin 1 for board layout compatibility with existing designs. Otherwise it is recommended pin 4 be grounded.
8. $BER \leq 10E-9$.

Parameter	Symbol	Min	Typical	Max	Unit	Test Condition
Peak POF Sensitivity: Minimum Input for Logic "0"	$P_{RL\ MIN}$		-23.0	-19.5	dBm	1 mm POF, PWD < 14 ns
Peak POF Overdrive Limit: Maximum Input for Logic "0"	$P_{RL\ MAX}$	-1.0	1.0		dBm	1 mm POF, PWD < 14 ns
Peak POF Off State Limit: Maximum Input for Logic "1"	$P_{RH\ MAX}$			-42	dBm	1 mm POF
Peak PCS Sensitivity: Minimum Input for Logic "0"	$P_{RL\ MIN}$		-25.0	-21.5	dBm	200 μ m PCS, PWD < 14 ns
Peak PCS Overdrive Limit: Maximum Input for Logic "0"	$P_{RL\ MAX}$	-3.0	0.0		dBm	200 μ m PCS, PWD < 14 ns
Peak PCS Off State Limit: Maximum Input for Logic "1"	$P_{RH\ MAX}$			-44	dBm	200 μ m PCS
Data Rate		DC		10	MBd	Min UI = 100 ns, Max f = 5 MHz
Supply Current	I_{CC}		15	22	mA	$V_O =$ Open Circuit
High Level Output Voltage	V_{OH}	4.45	4.99		V	$I_O = -40$ μ A
Low Level Output Voltage	V_{OL}		0.1	0.2	V	$I_O = 1.6$ mA
Output Rise Time (20%-80%)	t_r	3	10	17	ns	$C_{LOAD} = 10$ pF
Output Fall Time (80%-20%)	t_f	3	8	15	ns	$C_{LOAD} = 10$ pF
Power Supply Noise Immunity with PCB filter	PSNI		0.4		V_{PP}	Filter = 2.7 Ω , 100 nF Sine Wave DC – 10 MHz
Power Supply Noise Immunity without PCB filter	PSNI		0.4		V_{PP}	Sine Wave DC – 1MHz, 10 MHz @ 25°C
1 st Pulse, Pulse Width Distortion	PWD-1st	-14	-4	6	ns	Optical power (-1 to -19.5 dBm)
Pulse Width Distortion (data or clock)	PWD	-8	4	12	ns	
1 st Pulse Propagation Delay	$t_{PropDly_1st}$	60	82	107	ns	
Propagation Delay, Low to High (OPTO-ELEC, Data/CLK)	$t_{PropDly_LH}$	56	78	102	ns	
Propagation Delay, High to Low (OPTO-ELEC, Data/CLK)	$t_{PropDly_HL}$	61	82	107	ns	

SPECIFICATIONS, Receiver (continued)

The following graphs include the typical variance over both temperature from -40 °C to +85 °C and power supply from 4.5 V to 5.5 V.

Mean: Nominal performance at 25°C and 5.0 V

Max: Typical maximum over temperature from -40°C to +85°C and Vcc from 4.5 V to 5.5 V.

Min: Typical minimum over temperature from -40°C to +85°C and Vcc from 4.5 V to 5.5 V.

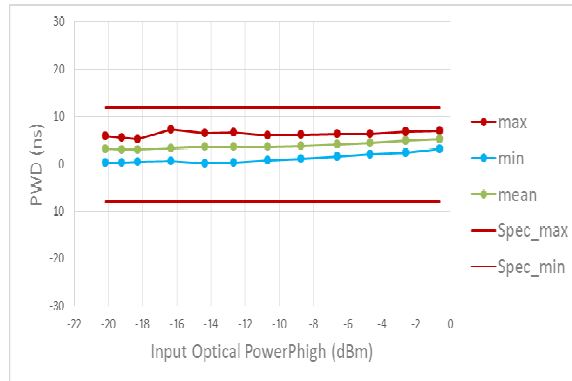

FIGURE 10
Pulse Width Distortion vs. Optical Input Power at 10 MBd.

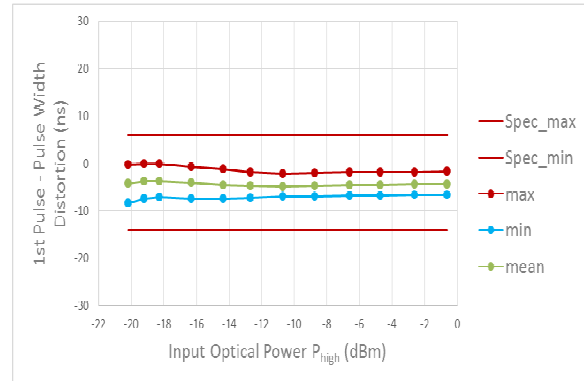

FIGURE 11
1st Pulse - Pulse Width Distortion vs. Optical Input Power.

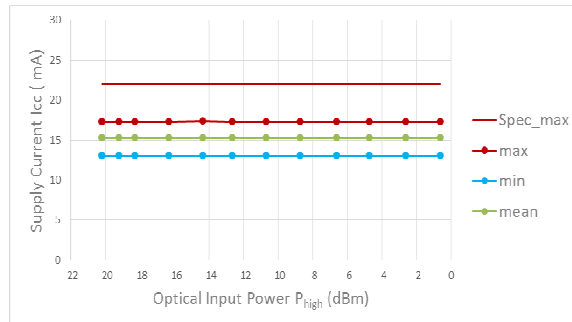

FIGURE 12
Supply Current over all operating conditions.

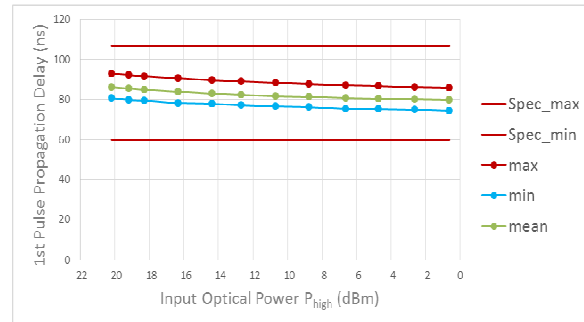

FIGURE 13
1st Pulse Propagation Delay over all operating conditions.

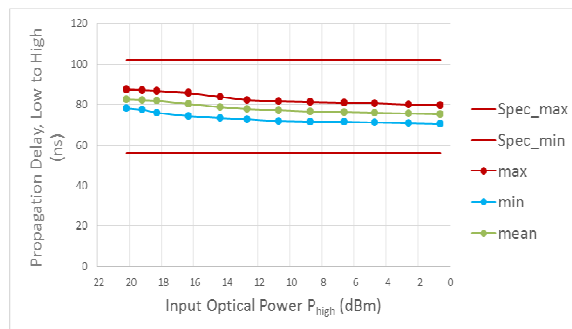

FIGURE 14
Propagation Delay for Output Low to High Transitions.

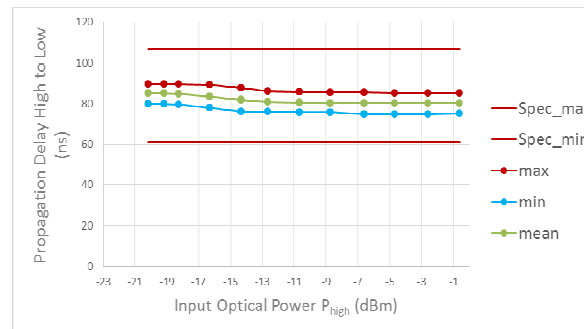

FIGURE 15
Propagation Delay for Output High to Low Transitions.

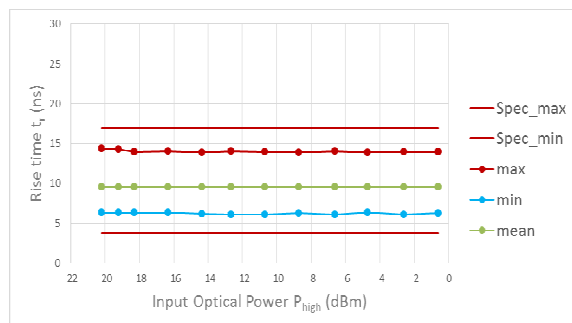

FIGURE 16
Receiver output rise time t_r over all operating conditions.

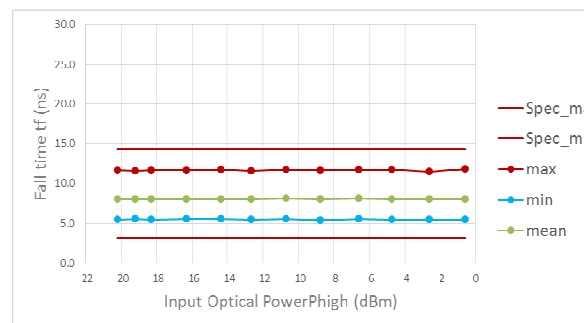

FIGURE 17
Receiver output fall time t_f over all operating conditions.

SPECIFICATIONS, Receiver (continued)

Table 7 RECEIVER PIN DESCRIPTION		
Pin	Name	Symbol
1	Receiver Output	V_o
2	Receiver Ground	GND
3	Receiver VCC	VCC
4	NO CONNECT	N/C
5	Retaining Pin	GND
8	Retaining Pin	GND

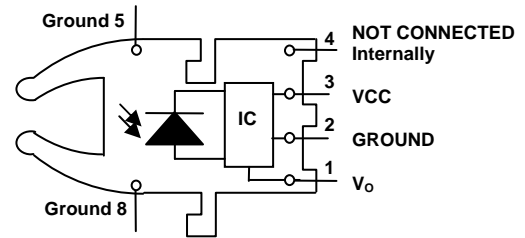

FIGURE 18
Receiver pin numbering.

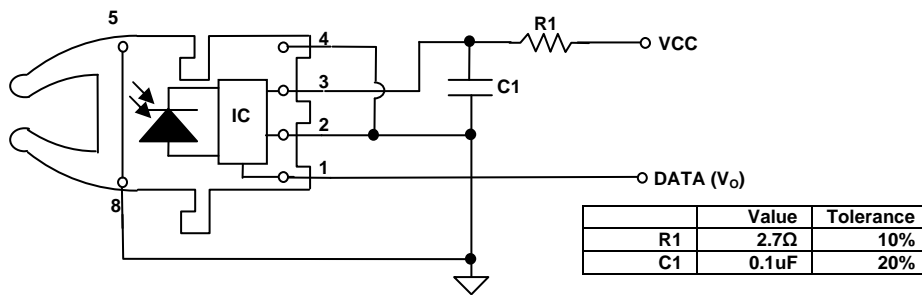

FIGURE 19
Recommended receiver application circuit.

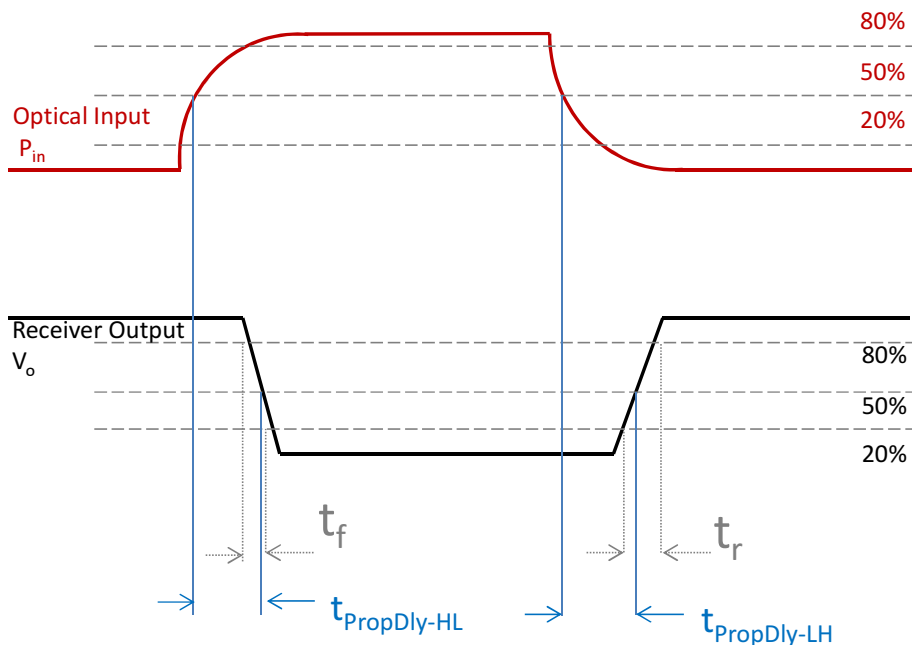

FIGURE 20
Definition of Receiver Propagation Delay, rise and fall times.

MECHANICAL DATA, Horizontal

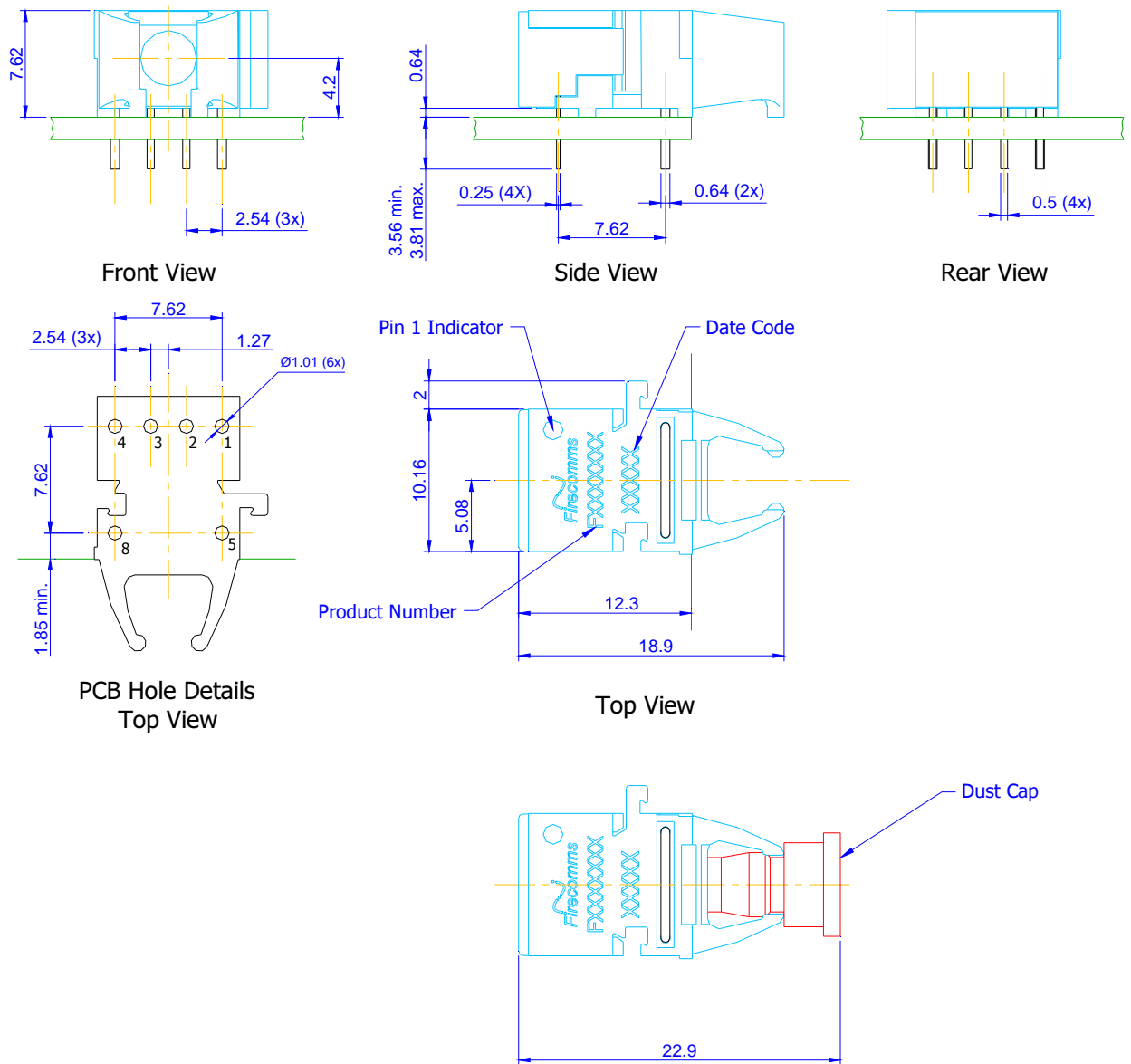

FIGURE 21
Mechanical dimensions of the Horizontal 10 Mbd RedLink connector and PCB footprint, which is a top view. General dimensional tolerance is ± 0.2 mm.

MECHANICAL DATA, Vertical

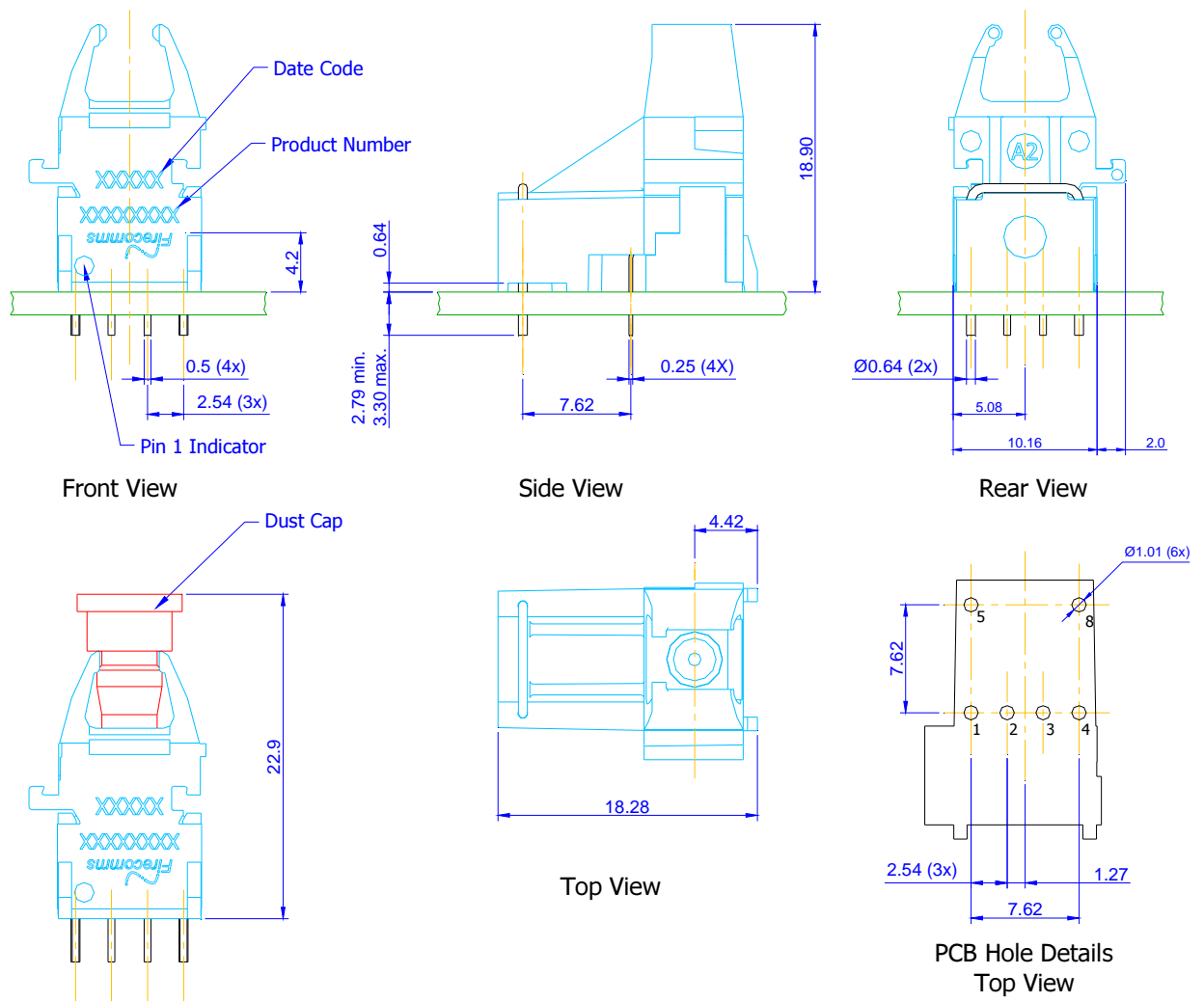

FIGURE 22
Mechanical dimensions of the Vertical 10 Mbd RedLink connector and PCB footprint, which is a top view.

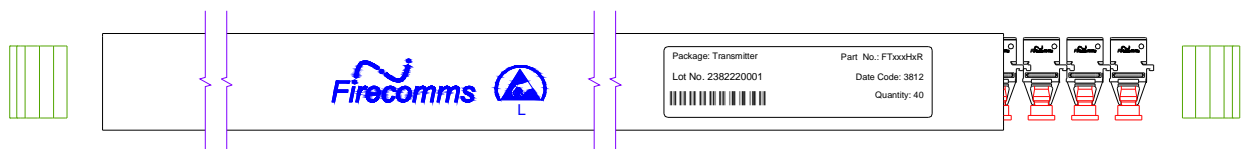

FIGURE 23
Packing tube for the Firecomms 10 MBd transmitter and/or receiver.

PACKING INFORMATION

Components are packed in PVC anti-static tubes in moisture barrier bags. Bags should be opened only in static-controlled locations, and standard procedures should be followed for handling moisture sensitive components.

Table 8 PACKING INFORMATION		
	Horizontal	Vertical
Components per Tube	40	40
Tube Length	515 mm	515 mm
Tube Height	16.2 mm	21.0 mm
Tube Depth	26.9 mm	30.8 mm
Tubes per Bag	5	5
Bags per Inner Carton	1	1
Inner Carton Length	630 mm	630 mm
Inner Carton Height	70 mm	70 mm
Inner Carton Depth	105 mm	105 mm
Weight per Inner Carton, Complete	0.48 Kg	0.66 Kg
Components per Inner Carton	200	200
Inner Cartons per Outer Carton	10	10
Outer Carton Length	650 mm	650 mm
Outer Carton Height	235 mm	235 mm
Outer Carton Depth	376 mm	376 mm
Weight per Outer Carton, Complete	5.28 Kg	6.98 Kg
Components per Outer Carton	2,000	2,000

ORDERING INFORMATION

Table 9 ORDERING INFORMATION		
Part Number	Name	Description
FT10MHNR	RedLink 10 MBd Transmitter, Horizontal	RedLink 650 nm, DC-10 MBd RCLED-Based Transmitter, Gray Housing, Horizontal
FR10MHIR	RedLink 10 MBd Receiver, Horizontal	RedLink DC-10 MBd Receiver, Black Housing, Horizontal
FT10MVNR	RedLink 10 MBd Transmitter, Vertical	RedLink 650 nm, DC-10 MBd RCLED-Based Transmitter, Gray Housing, Vertical
FR10MVIR	RedLink 10 MBd Receiver, Vertical	RedLink DC-10 MBd Receiver, Black Housing, Vertical