

# DC-1 MBd RedLink® Transmitter and Receiver Pair

DATA SHEET



## 650 nm DC-1 MBd RedLink® Fiber Optic Transmitter and Receiver



### FEATURES

- Ideal for use with POF
- Optimized for data transmission from DC to 1 MBd
- Industrial temperature range -40°C to +85°C
- RoHS and UL compliant
- Flame retardant (UL 94 V-0) connector housings
- RCLED transmitter with visible red light (650 nm wavelength)
- Fully integrated IC receiver with dual differential photo-diodes and integrated TIA and TTL output
- 5V TTL/CMOS compatible I/O for ease of design
- Low pulse width distortion
- Compatible with Versatile Link cables and connectors

### APPLICATIONS

Table 1 APPLICATIONS	
Application	Motor Control, Voltage Isolation, Drives, Inverters, Industrial Control, Gaming, Medical Imaging
Standard	Low-speed serial RS232, RS485, CAN Bus, Modbus, Profibus
Distance	50 meters Step Index (SI) POF in typical operating conditions 30 meters in worst case conditions
Speed	DC to 1 MBd (NRZ)

### DESCRIPTION

The Firecomms DC to 1 MBd RedLink® transmitter is based on the highly reliable Firecomms Resonant Cavity Light Emitting Diode (RCLED) technology. The receiver is based on a fully integrated differential photo-diode with TIA and limiting amplifier.

Housed in non-conducting plastic RedLink connector housings, the 1 MBd transmitter is gray while the 1 MBd receiver is blue. The housings are compatible with the Versatile Link style fiber plug and are optimized for use with Plastic Optic Fiber (POF).

The transmitter can be driven from TTL type logic drivers and the receiver is single-ended TTL/CMOS type output. Both transmitter and receiver operate over the industrial temperature range of -40°C to +85°C supporting many industrial applications where reliable command and control response is required in electrically harsh environments.

The transmitter uses a large-current aperture (150 µm diameter) red (650 nm) eye-safe RCLED based on InGaP/InGaAlP/GaAs technology. It operates over a wide range of drive current that can be adjusted using a serial resistor to minimize current consumption for a given link distance.

The receiver uses a monolithic IC with fully integrated dual photo-diodes which act as a differential light sensor, giving enhanced immunity to EMI/EMC from the local environment making the unit ideal for use in electrically noisy applications. It has a single data output compatible with TTL/CMOS electronics. The receiver is typically used at 1 MBd over POF in industrial serial bus protocol links.

**SPECIFICATIONS, General**

**Table 2**  
**DC-1 MBd TRANSMITTER AND RECEIVER ABSOLUTE MAXIMUM RATINGS**

*These are the absolute maximum ratings at or beyond which the FOT can be expected to be damaged.*

Notes:

1. 260°C for 10 seconds, one time only, at least 2.2 mm away from lead root.
2. When peak forward current exceeds 60 mA then the duty cycle must maintain a pulse width (PW) less than 1 μs and average forward current less than or equal to 60 mA.  $[60 \text{ mA} \leq I_{\text{FPK}} \leq 90 \text{ mA} \leftrightarrow I_{\text{FAVG}} \leq 60 \text{ mA AND PW} \leq 1 \mu\text{s}]$

Parameter	Symbol	Minimum	Maximum	Unit
Storage Temperature	T <sub>stg</sub>	-40	+85	°C
Operating Temperature <sup>[1]</sup>	T <sub>op</sub>	-40	+85	°C
Soldering Temperature <sup>[1]</sup>	T <sub>slid</sub>		+260 <sup>[1]</sup>	°C
TX Reverse Input Voltage	V <sub>BR</sub>		10	V
TX Peak Forward Input Current <sup>[2]</sup>	I <sub>FPK</sub>		1000	mA
TX Forward Input Current <sup>[2]</sup>	I <sub>FDC</sub>		80	mA
Storage Compliance (TX, RX)	MSL		2a	J-STD-020D
RX Supply Voltage	V <sub>cc</sub>	-0.5	+5.5	V
RX Output current	I <sub>OAVG</sub>		25	mA

**Table 3**  
**DC-1 MBd TRANSMITTER AND RECEIVER REGULATORY COMPLIANCE**

Parameter	Symbol	Standard	Level
Electrostatic Discharge, Human Body Model (contact ESD)	HBM	Mil-STD-883	Level 2 (4 kV)
Radiated Emissions Immunity	Vm <sup>-1</sup>	IEC 61000-4-3	15 Vm <sup>-1</sup>
UL Certification	UL	94 V-0 material	Files No. E362227
Storage Compliance	MSL	J-STD-020D	2a (4 week floor life)
Restriction of Hazardous Substances Directive	RoHS	Directive 2002/95/EC	Certified compliant
Eye Safety		IEC 60825-1	LED Class 1

**SPECIFICATIONS, Handling**

Firecomms 1 MBd RedLink devices are color coded, transmitters are gray and receivers are blue. The devices are auto-insertable and are tested for handling in static controlled assembly processes (HBM and CDM). Cleaning, degreasing and post solder washing should be carried out using standard solutions compatible with both plastics and the environment. For example, recommended solutions for degreasing are alcohols (methyl, isopropyl and isobutyl). In the soldering process, non-halogenated water soluble fluxes are recommended. RedLink products are not suitable for use in reflow solder processes (infrared/vapor-phase reflow). The dust plug should be kept in place during soldering, washing and drying processes to avoid contamination of the active optical area of each connector.

## SPECIFICATIONS, Transmitter (continued)

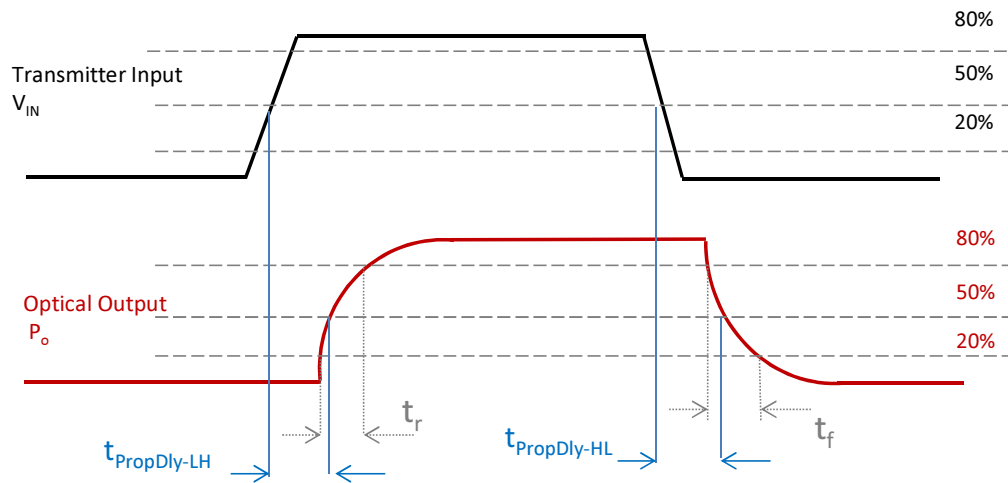
**Table 3**  
**TRANSMITTER ELECTRICAL AND OPTICAL CHARACTERISTICS**

**Test Conditions:**

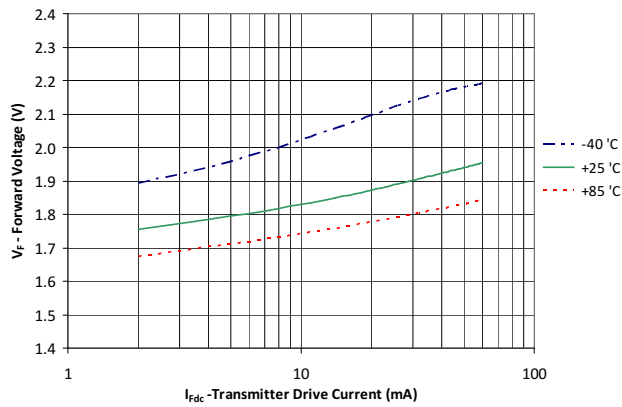
1. Test data was validated over the full temperature range of -40°C to +85°C, and over the full drive current range.
2. Optical power for POF is measured when coupled into 0.5 m of a 1 mm diameter 0.5 NA POF and a large area detector.
3. As measured in the given application circuit (non-inverting) as shown in Figure 7 with 50 cm of 0.5 NA POF
4. Emission Wavelength (centroid)  $\lambda_c = \sum_i P_i \lambda_i / \sum_i P_i$ . (Ref: EIA/TIA std. FOTP-127/6.1, 1991)
5. Spectral Width Root Mean Squared (RMS)  $\lambda_{RMS} = (\sum_i P_i (\lambda_c - \lambda_i)^2 / \sum_i P_i)^{1/2}$ . (Ref: EIA/TIA std. FOTP-127/6.3, 1991).

Parameter	Symbol	Min	Typical	Max	Unit	Test Condition
Output Optical Power	$P_o$	-14	-9.0	-4	dBm	$I_{FDC} = 60 \text{ mA}$
Emission Wavelength (centroid) <sup>[4]</sup>	$\lambda_c$	635	650	665	nm	$I_{FDC} = 30 \text{ mA}$
Spectral Width (RMS) <sup>[5]</sup>	$\lambda_{RMS}$		11	16	nm	$I_{FDC} = 30 \text{ mA}$
Emission Wavelength Temperature Coefficient	$\Delta\lambda_c/\Delta T$		0.1		nm/°C	$I_{FDC} = 30 \text{ mA}$
Forward Voltage	$V_F$	1.6	1.95	2.4	V	$I_{FDC} = 60 \text{ mA}$
Forward Voltage Temperature Coefficient	$\Delta V_F/\Delta T$		-2.8		mV/°C	$I_{FDC} = 60 \text{ mA}$
Reverse Input Breakdown Voltage	$V_{BR}$	10			V	$I_{FDC} = -1 \mu\text{A}$
Diode Capacitance	$C_o$		11		pF	$V = 0 \text{ V}$
TX Numerical Aperture	NA		0.5			$I_{FDC} = 60 \text{ mA}$
Data Rate		DC		1	MBd	$I_{FAVG} = 30 \text{ mA}$ , Min UI = 1 $\mu\text{s}$ , Max f = 0.5 MHz
Optical Rise Time (20%-80%)	$t_r$		9	11	ns	$I_{FAVG} = 30 \text{ mA}$ <sup>[3]</sup> Fig1
Optical Fall Time (80%-20%)	$t_f$		3	5	ns	$I_{FAVG} = 30 \text{ mA}$ <sup>[3]</sup> Fig 1
Propagation Delay Low-to-High (Electrical-to-Optical)	$t_{PropDly\_LH}$	22	30	42	ns	$I_{FAVG} = 30 \text{ mA}$ <sup>[3]</sup> Fig 1
Propagation Delay High-to-Low (Electrical-to-Optical)	$t_{PropDly\_HL}$	17	22	30	ns	$I_{FAVG} = 30 \text{ mA}$ <sup>[3]</sup> Fig 1
Pulse Width Distortion	PWD	-12	-8	-4	ns	$I_{FAVG} = 30 \text{ mA}$ <sup>[3]</sup>

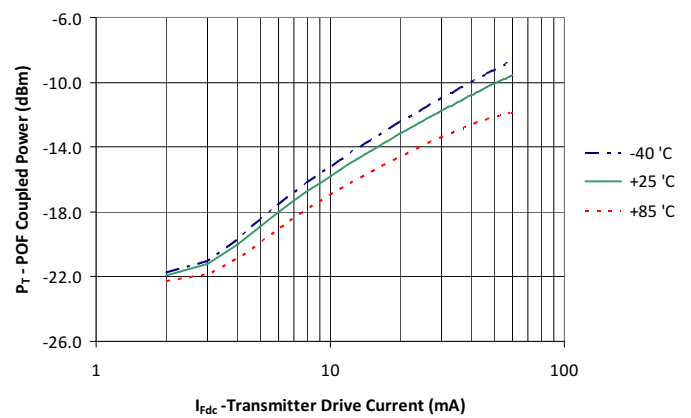
**SPECIFICATIONS, Transmitter (continued)**



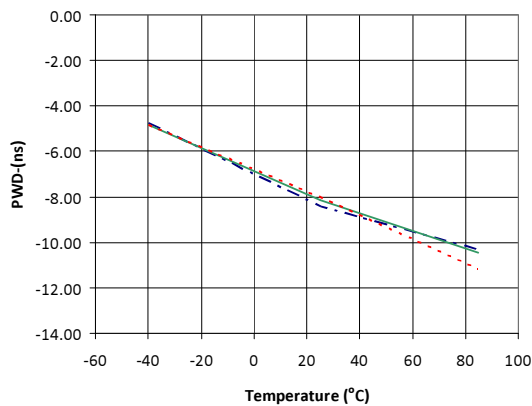
**FIGURE 1**  
Transmitter propagation delay and rise/fall time definitions as per application circuit of Figure 6.



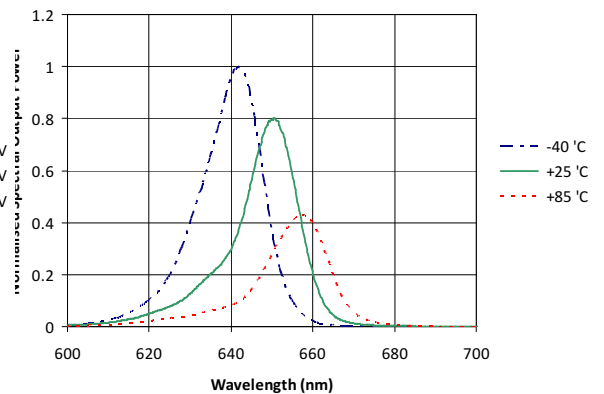
**FIGURE 2**  
Typical forward voltage vs. drive current.



**FIGURE 3**  
Typical optical output power vs. drive current.



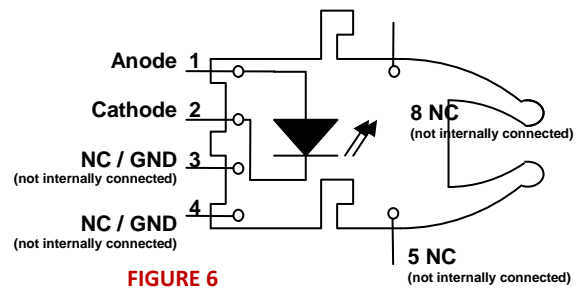
**FIGURE 4**  
Typical pulse width distortion vs. temperature.



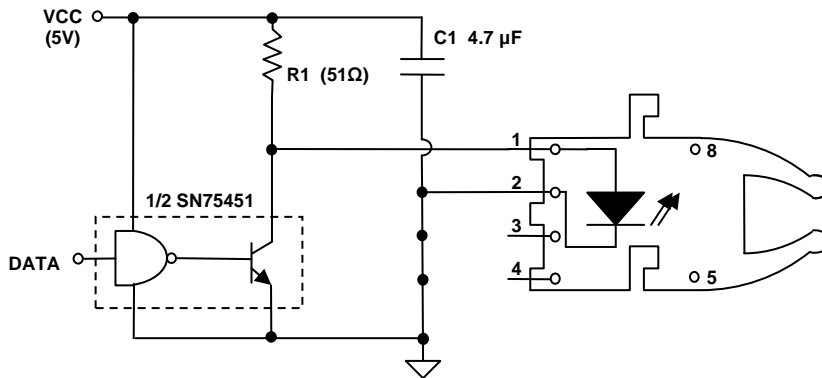
**FIGURE 5**  
Typical spectra vs. temperature.

**SPECIFICATIONS, Transmitter (continued)**

Table 4 TRANSMITTER PIN DESCRIPTION		
Pin	Name	Symbol
1	RCLED ANODE	TX+
2	RCLED CATHODE	TX-
3	Not Connected	N.C.
4	Not Connected	N.C.
5	Retaining Pin	N.C.
8	Retaining Pin	N.C.

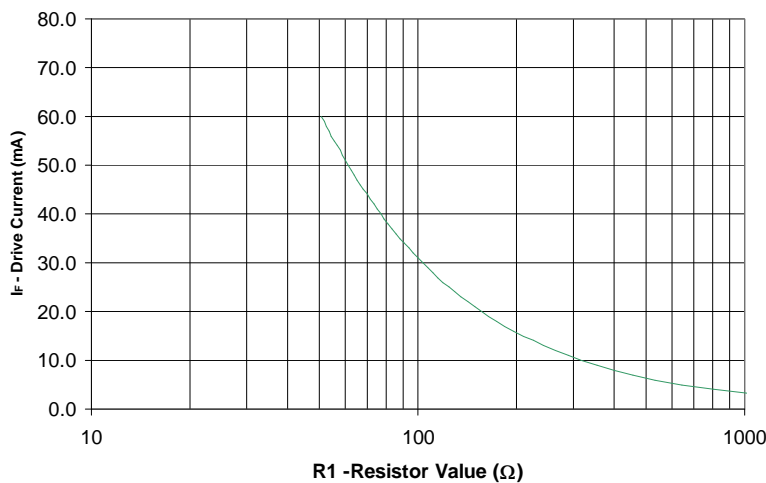


**FIGURE 6**  
Transmitter pin numbering.



**NOTE:**  
R1 = 51 Ω, then I<sub>F</sub> drive current is approximately 60 mA. To reduce drive current, select a higher R1 value. Please see the graph shown in Figure 8 to select R1 and drive current.

**FIGURE 7**  
Non-inverting application circuit for the FT01MHNR; for temperature range 0°C to +70°C, use SN75451B as the driver IC, for temperature range -40°C to +85°C, use SN55451B. I<sub>F,ON</sub> = 60 mA nominal at +25°C.



**FIGURE 8**  
Graph of drive current against series resistance (R1).

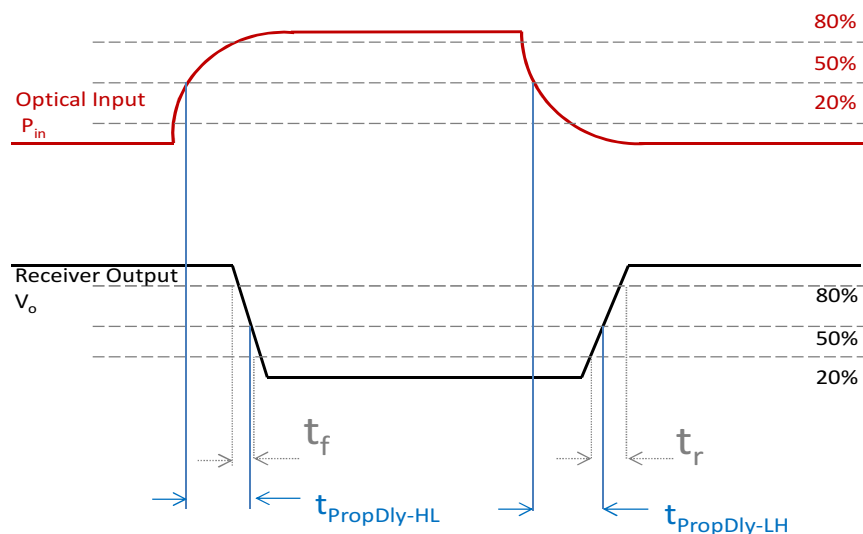
## SPECIFICATIONS, Receiver

**Table 5**  
**RECEIVER ELECTRICAL AND OPTICAL CHARACTERISTICS**

**Test Conditions:**

1. Test data was validated over the full temperature range of  $-40^{\circ}\text{C}$  to  $+85^{\circ}\text{C}$ , and over the full voltage range of 4.5V to 5.5V unless otherwise noted. Typical data are at  $+25^{\circ}\text{C}$  with  $V_{CC} = 5\text{V}$ .
2. Input power levels are for peak (not average) optical input levels. For 50% duty cycle data, peak optical power is twice the average optical power. Optical power for POF is measured when coupled into 0.5 m of a 1 mm diameter 0.5 NA POF and using a large area detector.
3. Pins 5 and 8 are for mounting and retaining purposes. Recommended to connect to ground plane, may be left open circuit.
4. In the recommended receiver circuit, with an optical signal from the recommended transmitter circuit.
5. Pin 4 is electrically isolated internally. Pin 4 may be externally connected to pin 1 for board layout compatibility in existing designs.

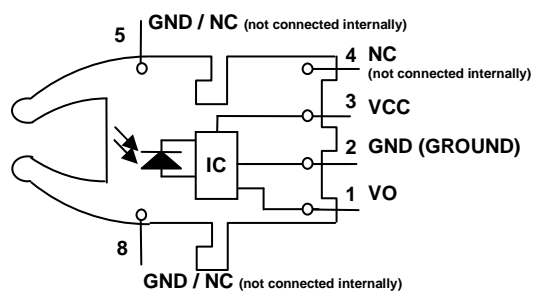
Parameter	Symbol	Min	Typical	Max	Unit	Test Condition
Input Optical Power Level for Logic "0"	$P_{RL}$	-22		-1	dBm	$V_{OL} \leq 0.4\text{ V}$ , $I_{OL} = 8\text{ mA}$ <sup>[2],[5]</sup>
Input Optical Power Level for Logic "1"	$P_{RH}$			-43	dBm	$V_{OH} \geq 4.45\text{ V}$ , $I_{OH} = -40\text{ }\mu\text{A}$ <sup>[2],[5]</sup>
High Level Output Voltage	$V_{OH}$	4.45	4.99		V	$I_{OH} = -40\text{ }\mu\text{A}$ , <sup>[4]</sup>
Low Level Output Voltage	$V_{OL}$		0.2	0.4	V	$I_{OL} = 8\text{ mA}$ , <sup>[4]</sup>
Supply Current	$I_{CC}$		13.7	20	mA	$P_R = -1\text{ to }-22\text{ dBm}$ <sup>[4]</sup>
Data Rate		DC		1	MBd	Min UI = 1 $\mu\text{s}$ , Max f = 0.5 MHz
Rise Time (20% - 80%)	$t_r$	4.4	11.4	19.8	ns	
Fall Time (80% - 20%)	$t_f$	2.0	5.2	10.1	ns	
1 <sup>st</sup> Pulse, Pulse Width Distortion	PWD-1 <sup>st</sup>	-40	-10	15	ns	
Pulse Width Distortion	PWD	-25	7	50	ns	$C_L = 10\text{ pF}$ , Optical Power -1 to -22 dBm
1 <sup>st</sup> Pulse Propagation Delay (OPTO-ELEC)	$t_{\text{PropDly\_1st}}$	32	52	79	ns	
Propagation Delay Low-to-High (OPTO-ELEC, Data/CLK)	$t_{\text{PropDly\_LH}}$	23	44	67	ns	
Propagation Delay High-to-Low (OPTO-ELEC, Data/CLK)	$t_{\text{PropDly\_HL}}$	20	49	86	ns	



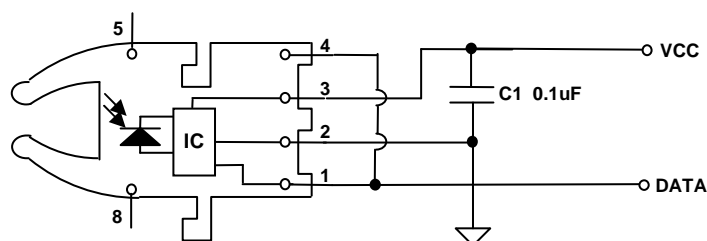
**FIGURE 9**  
**Receiver Propagation Delay and rise/fall time definitions.**

## SPECIFICATIONS, Receiver (continued)

Table 6 RECEIVER PIN DESCRIPTION		
Pin	Name	Symbol
1	Receiver Output	Vo
2	Receiver Ground	GND
3	Receiver Vcc	Vcc
4	Not Connected	N.C.
5	Retaining Pin	GND/N.C.
8	Retaining Pin	GND/N.C.

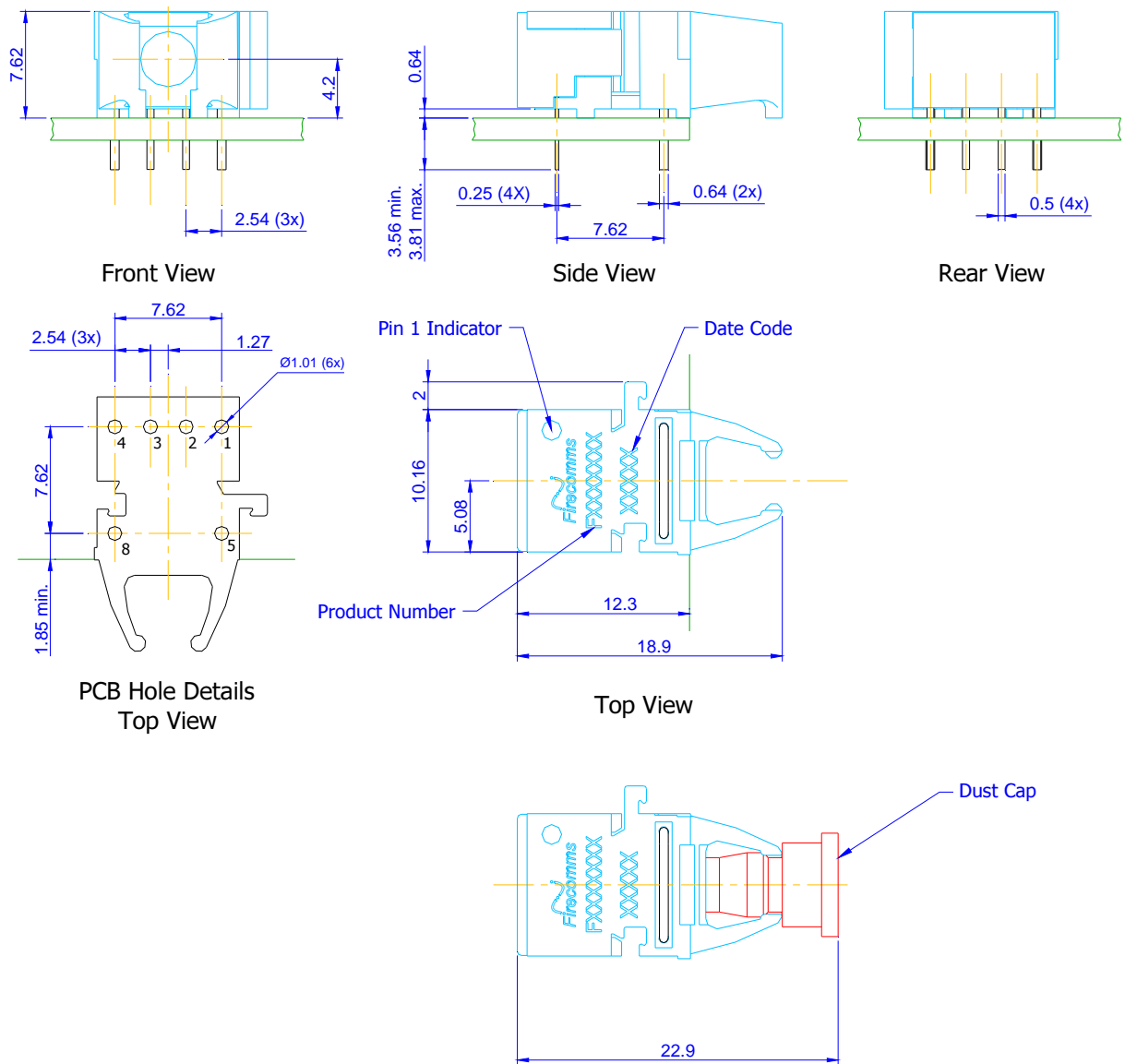


**FIGURE 10**  
RedLink receiver pin numbering.



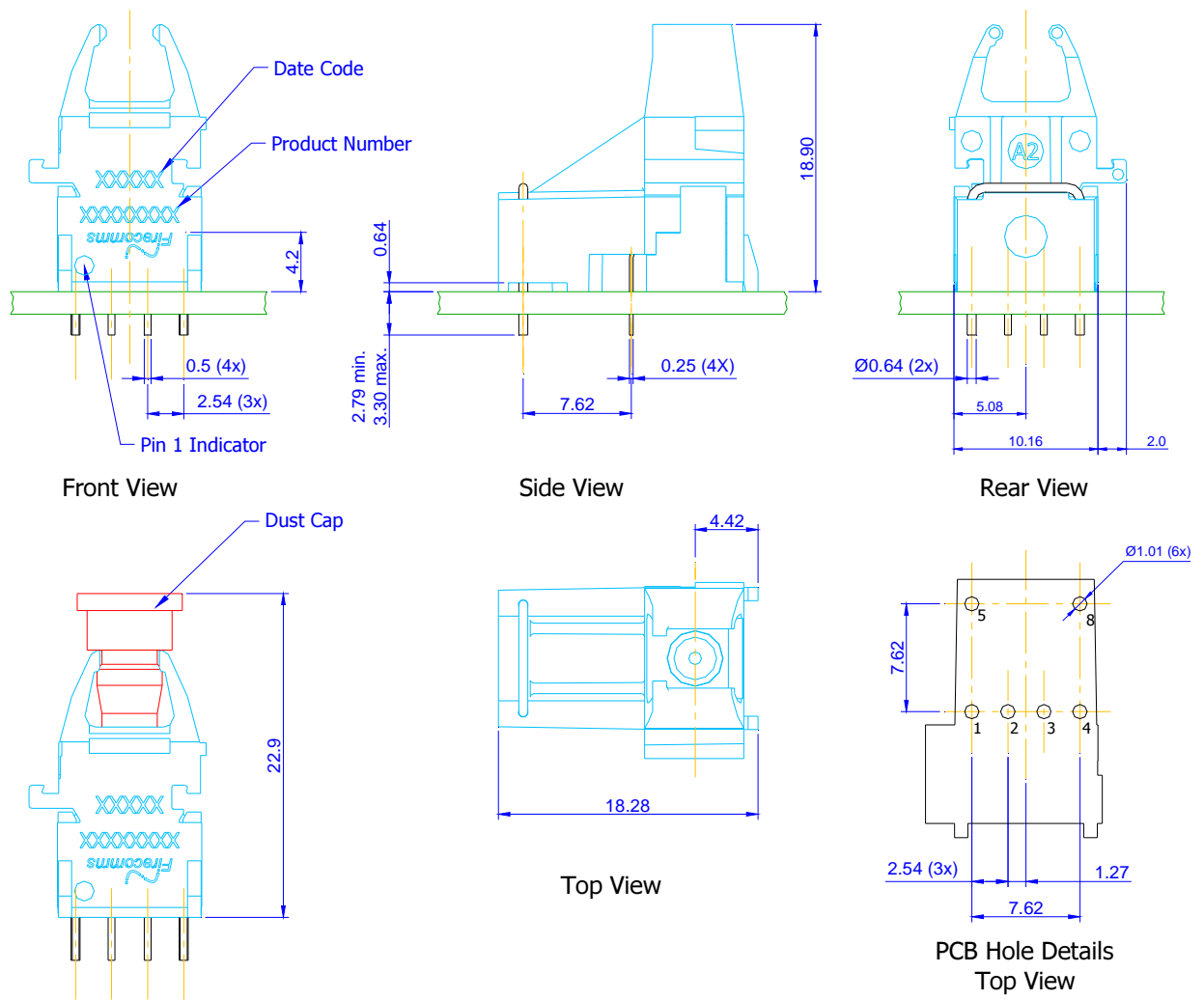
**FIGURE 11**  
RedLink receiver interface circuit.

**MECHANICAL DATA, Horizontal**

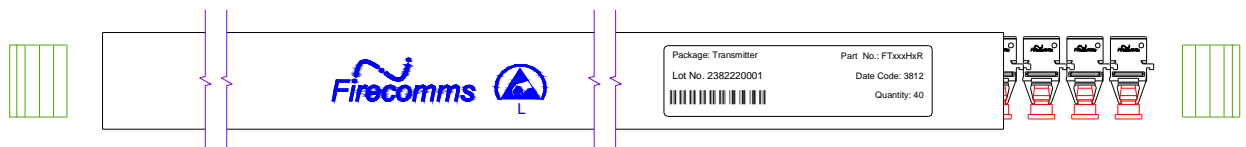


**FIGURE 12**  
**Mechanical dimensions of the Horizontal 1 MBd RedLink transmitter and receiver connectors and PCB footprint, which is a top view. General dimensional tolerance is  $\pm 0.2$  mm.**

**MECHANICAL DATA, Vertical**



**FIGURE 13**  
**Mechanical dimensions of the Vertical 1 MBd RedLink transmitter and receiver connectors and PCB footprint, which is a top view. General dimensional tolerance is  $\pm 0.2$  mm.**



**FIGURE 14**  
**Packing tube for the Firecomms 1 MBd transmitter and/or receiver.**

**PACKING INFORMATION**

Components are packed in PVC anti-static tubes in moisture barrier bags. Bags should be opened only in static-controlled locations, and standard procedures should be followed for handling moisture sensitive components.

<b>Table 7 PACKING INFORMATION</b>			
		<b>Horizontal</b>	<b>Vertical</b>
Components per Tube		40	40
	Tube Length	515 mm	515 mm
	Tube Height	16.2 mm	21.0 mm
	Tube Depth	26.9 mm	30.8 mm
Tubes per Bag		5	5
Bags per Inner Carton		1	1
	Inner Carton Length	630 mm	630 mm
	Inner Carton Height	70 mm	70 mm
	Inner Carton Depth	105 mm	105 mm
Weight per Inner Carton, Complete		0.48 Kg	0.66 Kg
Components per Inner Carton		200	200
Inner Cartons per Outer Carton		10	10
	Outer Carton Length	650 mm	650 mm
	Outer Carton Height	235 mm	235 mm
	Outer Carton Depth	376 mm	376 mm
Weight per Outer Carton, Complete		5.28 Kg	6.98 Kg
Components per Outer Carton		2,000	2,000

**ORDERING INFORMATION**

<b>Table 8 ORDERING INFORMATION</b>		
<b>Part Number</b>	<b>Name</b>	<b>Description</b>
FT01MHNR	RedLink 1 MBd Transmitter, Horizontal	RedLink 650 nm, Horizontal, DC-1 MBd RCLED-Based Transmitter, Gray Housing
FR01MHIR	RedLink 1 MBd Receiver, Horizontal	DC-1 MBd Receiver, Horizontal, Blue Housing
FT01MVNR	RedLink 1 MBd Transmitter, Vertical	RedLink 650 nm, Vertical, DC-1 MBd RCLED-Based Transmitter, Gray Housing
FR01MVIR	RedLink 1 MBd Receiver, Vertical	DC-1 MBd Receiver, Vertical, Blue Housing