

DATA SHEET



Model : COSMOS

Ver. 1.5

MAY 03, 2007

CONTENTS

1.	Revisions of History	-----	3
2.	General Descriptions	-----	4
3.	Features	-----	4
4.	Block Diagram	-----	5
5.	Outline Dimensions	-----	6
6.	Connectors Information	-----	11
7.	Reference Data	-----	16
8.	Supported Input Formats	-----	17
9.	OSD board information	-----	20

The information presented in this document may form a part of quotation or contract under the agreement of both parties. Otherwise, this datasheet is subject to change without prior notice.

1. Revisions of History

Revision No.	Date	Page	Description
Ver. 1.0	Dec. '06	1~20	First Draft, Preliminary Specification
Ver. 1.1	Feb. '07	21~36	OSD Menu Summary
Ver. 1.2	Mar. '07	6, 8, 10	Update All board dimension
Ver. 1.3	Mar. '07	10, 11	Update round DIN4pin power input
Ver. 1.4	APR. '07	4, 24, 26	Update OSD menu, Add Faroudja option
Ver. 1.5	MAY. '07		Add optional Audio board sheet.

2. General Descriptions

Cosmos is an advanced TFT-LCD Monitor Control Board. This design enables a full conventional CRT monitor and/or video replacement with a large size Active Matrix LCD module. It is suitable for video resolution up to WUXGA @ 60Hz(1200 vertical by 1920 horizontal pixel array) in all video modes, the full display area of the module is used. The design is implemented as a single printed circuit board.

Cosmos is designed to support various TFT-LCDs up to WUXGA resolution by BIOS option.

3. Features

- Designed to give state-of-the-art picture quality
- Analog RGB / DVI (Digital Video Interface) / Component(Y/Pb/Pr) / CVBS / S-video.
- Optional input combination, e.g., PC monitor only
- Full CRT multi-sync monitor compatibility
- Multi-sync capability up to WUXGA resolution @ 60Hz, compatible standard SVGA, XGA and SXGA VESA timing.
- Expand DOS,VGA,SVGA,XGA, SXGA, UXGA and WUXGA to full screen display
- True color (16.7M) data processing and display driving
- Single control operated & transparent On-Screen-Display (hereafter 'OSD') user interface
- Full control of all relevant display and interface parameters via OSD
- PIP & PBP function available.
- VESA DDC 1/2B compliant
- Compatible with VESA DPMS power saving modes
- Form factor: 110mm (L) x 150mm (W) x 17mm(H)
- +12V or +24V DC single power
- Operating temperature: 0°C to 50°C
- The IR & RS232 function (full remote control)integrated.
- OSD & Power Switch Board : FOSD-xxx
- FAROUDJA VIDEO PROCESSING (OPTIONAL)
 1. Motion Adaptive De-interlacing (MADi)
 2. Inverse 3:2/2:2 pull down for Film Mode
 3. DCDi Edge Processing
 4. Temporal Noise Reduction (TNR) up to 720P
 5. Cross Color Reduction
 6. Faroudja True-life Horizontal Enhancement

4. Block Diagram

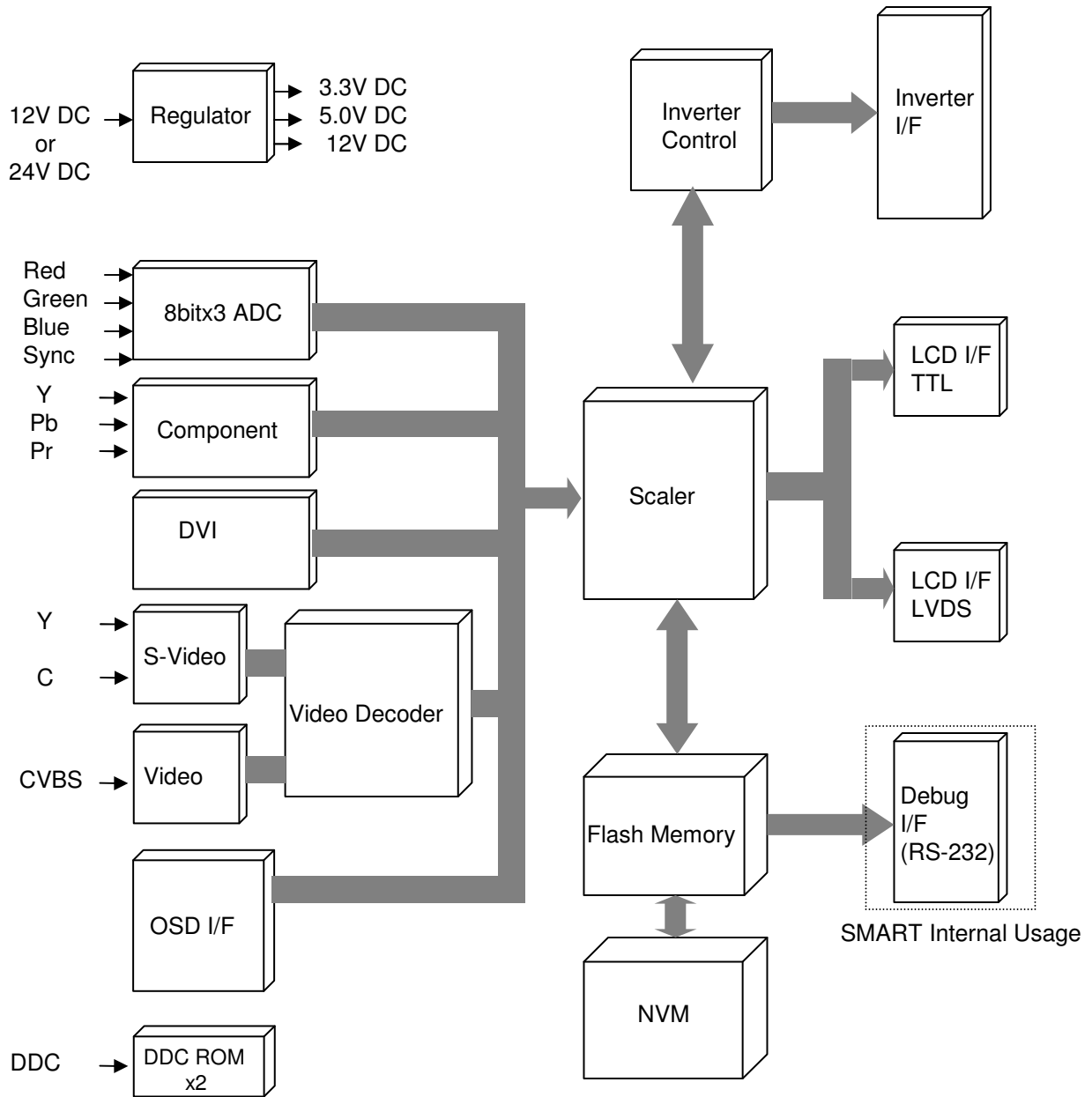

5.1.1 Actual connectors location

- Analog, DVI, and Video

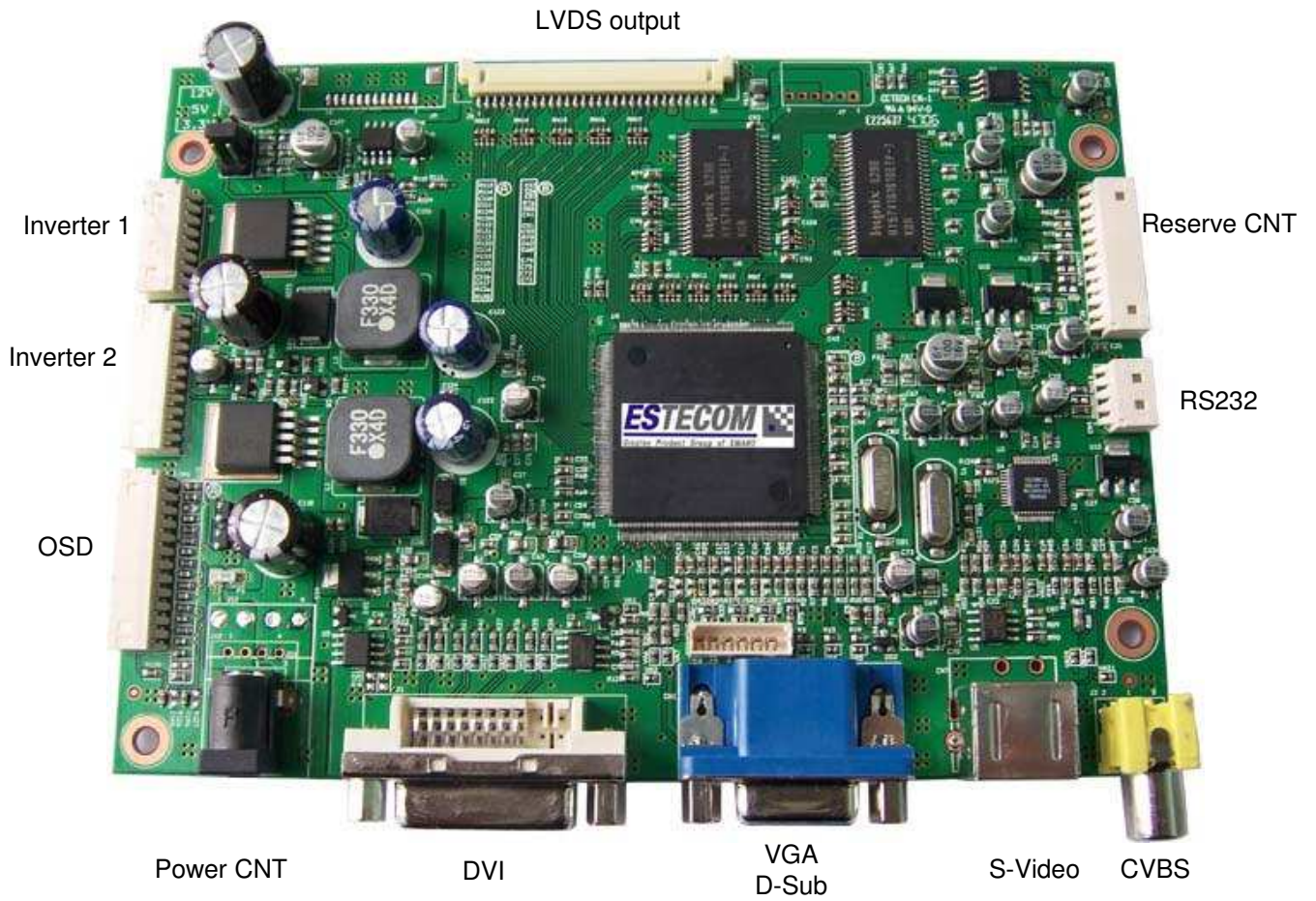

5.2 Standard Connectors with Special Power connector 4P angle (3.96mm pitch)

- Dimension : 110mm (L) x 150mm (W) x 17mm(H)

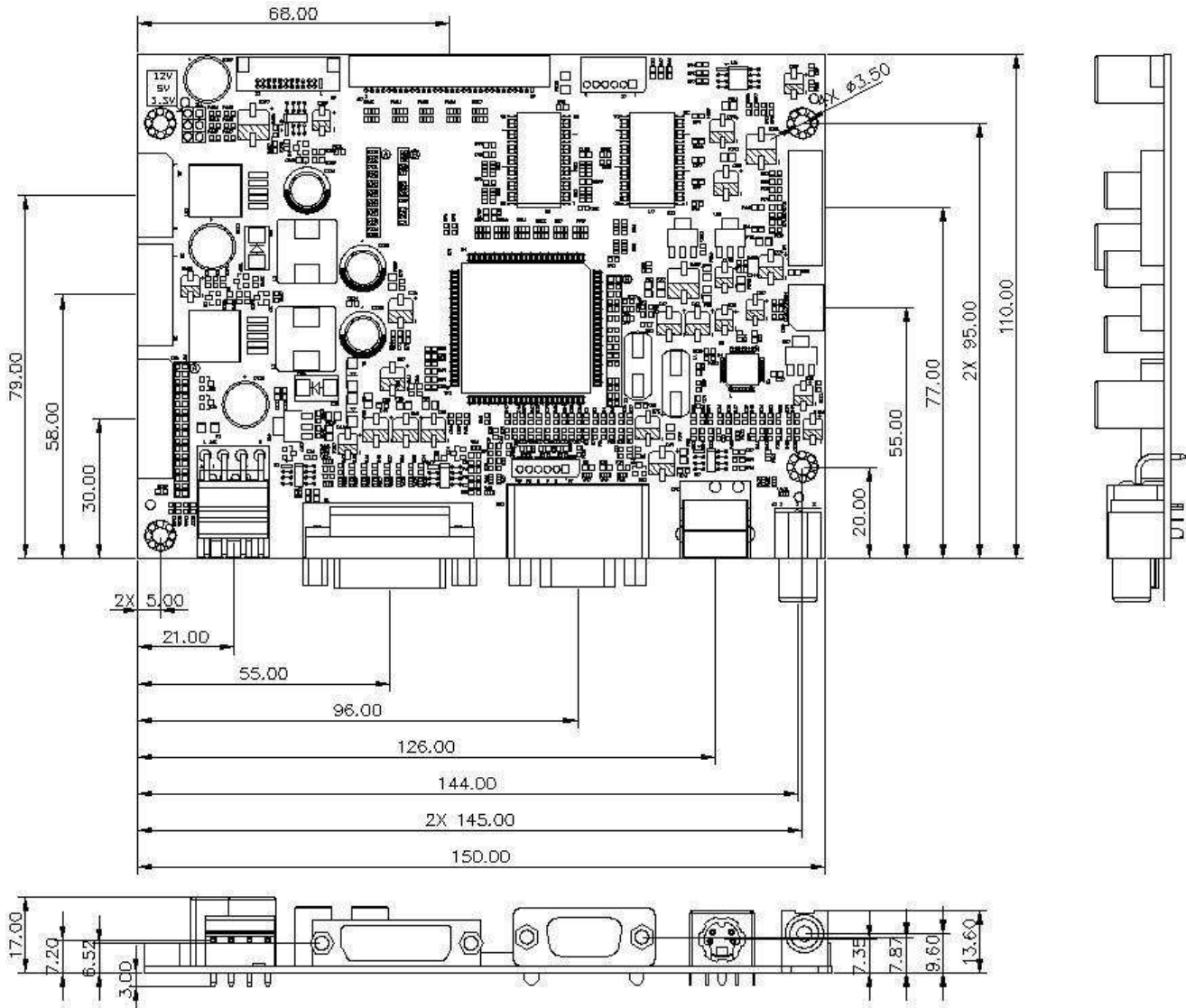

5.2.1 Actual connectors location

- Analog, DVI, and Video

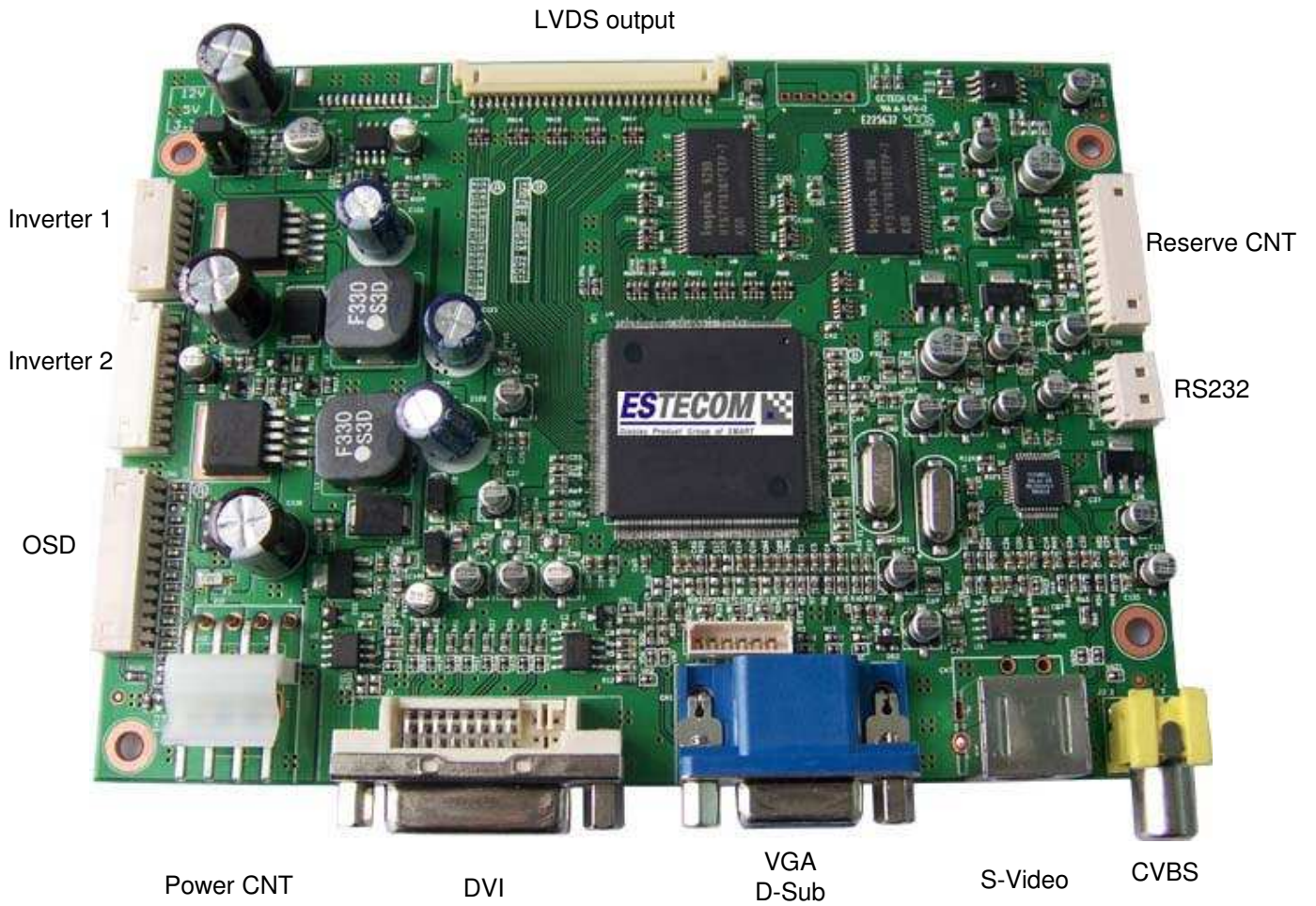

5.2 Standard Connectors with round DIN4P for high current

- Dimension : 110mm (L) x 150mm (W) x 17mm(H)

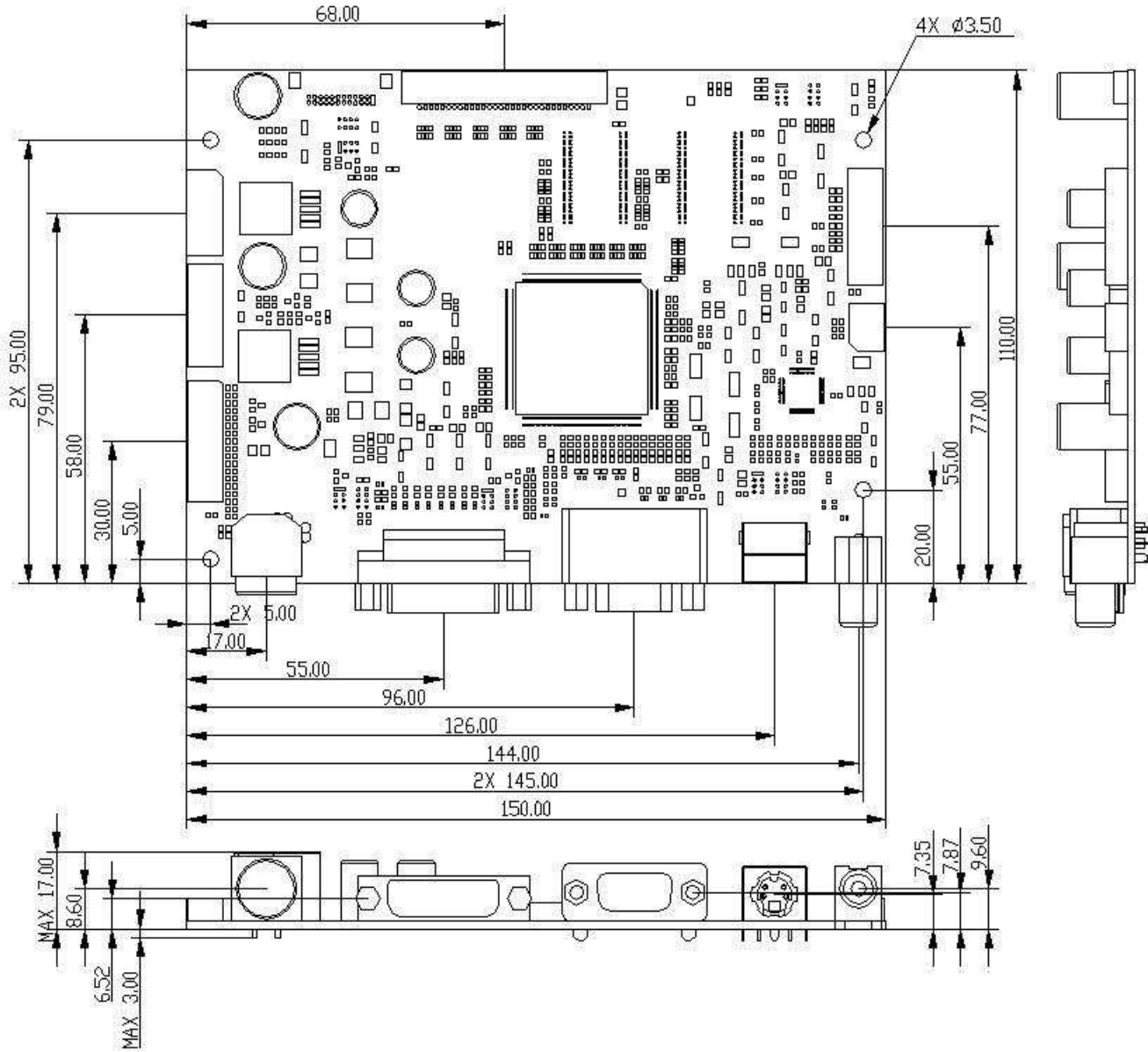

5.2.1 Actual connectors location

- Analog, DVI, and Video

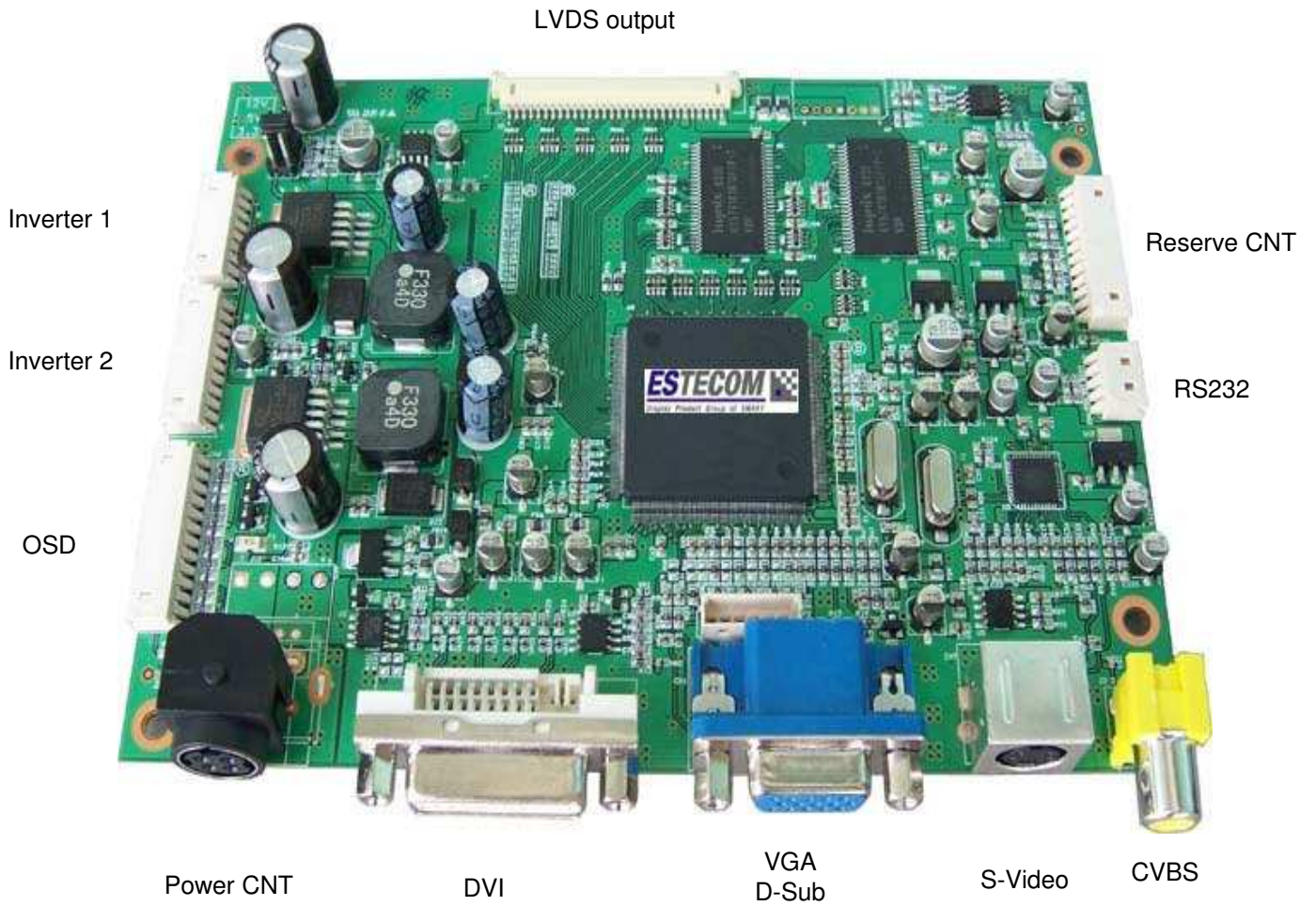

5.3 Component daughter board

- Dimension : 15.5mm (L) x 45.5mm (W) x 13.6mm(H)

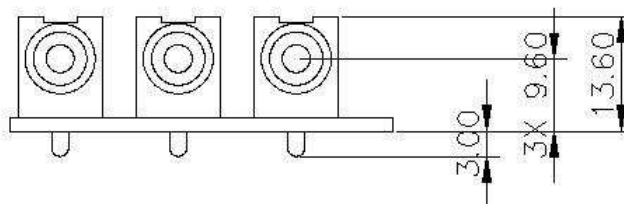
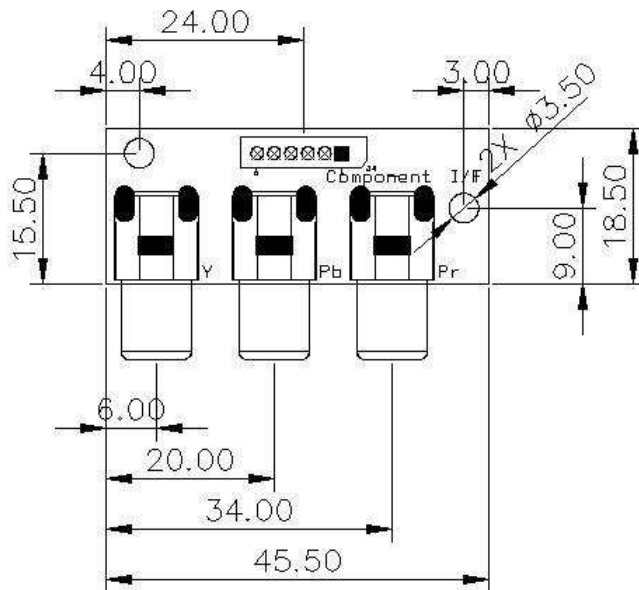

- Component input (Y/Pb/Pr)

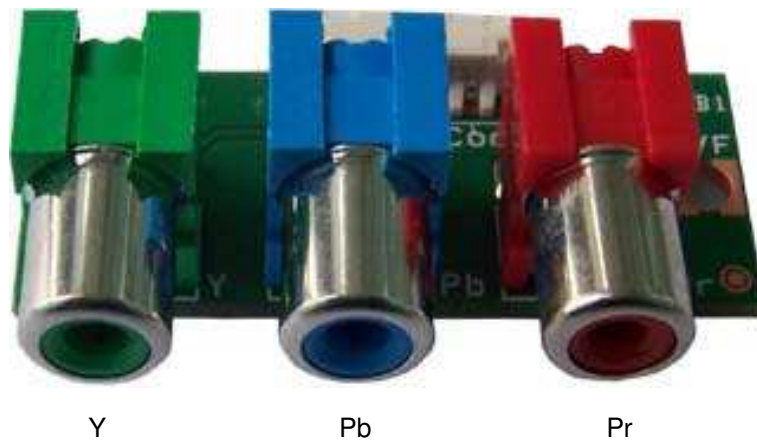

Y

Pb

Pr

6. Connectors Information

6.1 Input Connectors

- Power Input Connector

Connector : DC12V Jack (J11)

Pin No.	Symbol	Description	Pin No.	Symbol	Description
1, 2	GND	GND	3	Vin	+12V DC

- Power Input Connector (**Alternative**)

Connector : Molex 09-75-2044 (J13)

Pin No.	Symbol	Description	Pin No.	Symbol	Description
1	VCC	POWER	3	GND	GND
2	VCC	POWER	4	GND	GND

- Analog RGB Input Connector

Connector : Mini D_Sub 15pin(CN1)

Pin No.	Symbol	Description	Pin No.	Symbol	Description
1	RED	Analog Red	9	NC	+5V DC
2	GREEN	Analog Green	10	SGND	Sync GND
3	BLUE	Analog Blue	11	NC	No Connection
4	GND	No Connection	12	SDA	DDC Serial Data
5	GND	Digital GND	13	HSYNC	Horizontal Sync
6	RGND	Red Return	14	VSYNC	Vertical Sync.
7	GGND	Green Return	15	SCL	DDC Data Clock
8	BGND	Blue Return			

- DVI-D Input Connector
 Connector : DVI-D (J1)

Pin No.	Symbol	Pin No.	Symbol	Pin No.	Symbol
1	T.M.D.S. Data 2-	9	T.M.D.S. Data 1-	17	T.M.D.S. Data 0-
2	T.M.D.S. Data 2+	10	T.M.D.S. Data 1+	18	T.M.D.S. Data 0+
3	T.M.D.S. Data2/4 Shield	11	T.M.D.S. Data1/3 Shield	19	T.M.D.S. Data 0/5 Shield
4	T.M.D.S. Data 4-	12	T.M.D.S. Data 3-	20	T.M.D.S. Data 5-
5	T.M.D.S. Data 4+	13	T.M.D.S. Data 3+	21	T.M.D.S. Data 5+
6	DDC Clock	14	+5V Power	22	T.M.D.S. Clock Shield
7	DDC Data	15	Ground	23	T.M.D.S. Clock+
			(Return for +5V, H-Sync, and V-Sync)		
8	N/C	16	Hot Plug Detect	24	T.M.D.S. Clock-

- Component Input Connector (Cosmos side)
 Input Connector : Molex 53014-0610 (CN2)

Pin No.	Symbol	Description	Pin No.	Symbol	Description
1	Pr	Pr	4	GND	Y return
2	GND	Pr return	5	Pb	Pb
3	Y	Y	6	GND	Pb return

- Component Input Connector (Component daughter board side)
 Input Connector : Molex 53014-0710 (J4)

Pin No.	Symbol	Description	Pin No.	Symbol	Description
1	GND	Pb return	5	Pr	Pr
2	Pb	Pb	6	GND	Pr return
3	GND	Y return	7	N.C	N.C
4	Y	Y			

● S-Video input Connector

Connector :MiniDin-4p (CN7)

Pin No.	Symbol	Description	Pin No.	Symbol	Description
1	GND1	GND1	4	S-VIDEO	CHROMA
2	GND2	GND2	5	GND3	GND3
3	S-VIDEO	LUMINANCE			

● CVBS Connector : RCA yellow (J2)

Pin No.	Symbol	Description	Pin No.	Symbol	Description
1,3	CVBS	Video signal	2	GND	Video return

● OSD, LED Interface Connector :

Connector : 53015-1210 made by Molex (CN6)

Pin No.	Symbol	Description	Pin No.	Symbol	Description
1	LED 1	LED 1	7	KEY2	Increase
2	LED 0	LED 0	8	KEY3	Decrease
3	Vcc	Vcc 5V	9	KEY4	Down
4	IR	Remote control	10	KEY5	Menu
5	GND	GND	11	KEY6	Source Select
6	KEY1	Power	12	KEY7	Up

● RS-232C Connector :

Connector : 53015-0410 made by Molex (CN4)

Pin No.	Symbol	Description
1	GND	GND
2	RX	TXD
3	TX	RXD
4	VCC	VCC

6.2 Output Connectors

- LVDS Output Connector (J6)

Pin No.	Symbol	Pin No.	Symbol
1	Tx0- E	16	Tx1+ O
2	Tx0+ E	17	GND
3	Tx1- E	18	Tx2- O
4	Tx1+ E	19	Tx2+ O
5	GND	20	TxCLK- O
6	Tx2- E	21	TxCLK+ O
7	Tx2+ E	22	Tx3- O
8	TxCLK- E	23	Tx3- O
9	TxCLK+ E	24	GND
10	Tx3- E	25	3.3V (LVDS option)
11	Tx3+ E	26	GND
12	GND	27	VCC
13	Tx0- O	28	VCC
14	Tx0+ O	29	VCC
15	Tx1- O	30	VCC

● Backlight Connector

Connector : 53015-0810 made by Molex (J6)

Pin No.	Symbol	Description	Pin No.	Symbol	Description
1	BRIGHT	Brightness Adjustment	5	GND	Ground
2	ON/OFF	Backlight On/Off	6	GND	Ground
3	GND	Ground	7	12V	12V
4	5V	5V (Not Use)	8	12V	12V

● Backlight Power Connector (For Large size panel)

Connector : 53015-1010 made by Molex(J8)

Pin No.	Symbol	Description	Pin No.	Symbol	Description
1	VDD	INV PWR	6	GND	Ground
2	VDD	INV PWR	7	GND	Ground
3	VDD	INV PWR	8	GND	Ground
4	VDD	INV PWR	9	GND	Ground
5	VDD	INV PWR	10	GND	Ground

7. Reference Data

Video Input Timing;

Supported vertical refresh rates for each modes are as follows:

640 x 350	70Hz
640 x 400	70Hz
700 x 560	55~75Hz
720 x 350	70Hz
720 x 400	70Hz
640 x 480	60~75Hz
800 x 600	60~75Hz
1024 x 768	60~75Hz
1152 x 864	60~75Hz
1280 x 1024	60~75Hz
1280 x 768	60~75Hz
1366 x 768	60~75Hz
1440 x 900	60~75Hz
1600 x1200	60~75Hz
1680 x1050	60~75Hz
1920 x1080	60Hz
1920 x1200	60Hz

Sync. : H/V Separated TTL, Composite Sync

● Electrical Parameters

Reference Cosmos, t_A 25 ° C

Symbol	Description	Min	Type	Max	Unit
V_{DD}	+12V (+24V) DC Power Supply	10.8	12.0	24.5	V
$V_{i(RGB)}$	Video Input Signal (w.r.t. GND)	0.5	0.7	1.0	V_{PP}
f_S	Video Sample Rate			80	MHz
f_{HS}	Horizontal Sync. Frequency	30		60	KHz
f_{VS}	Vertical Sync Frequency	56		75	Hz
F_{SIH}	Sync Input High Level	2.5			V
V_{SIL}	Sync Input Low Level			0.8	VDC
I_{DD2}	Supply Current +12V (with LCD & Inverter)		2.5	3	A

Note 1. Power consumption measuring condition is 2 pixel check board pattern @ SXGA 75Hz and maximum brightness with Samsung LTM170E6 & inverter at t_A 25°C.

8. Supported Input Formats

8.1 Video Mode Support

The Cosmos series can support any video mode within the following input constraints:

- Signal sample frequency with the input $\leq 80\text{MHz}$
- Horizontal sync frequency between 30KHz and 80KHz

The modes are detected with the presentation of the input and previous alignments for setup are Automatically recalled. The emulation of a true multi-sync monitor is implemented.

The factory preset supported modes are as follows:

Mode	Resolution	Refresh rate	H-freq.	Pixel freq.	Remarks
VGA	640 x 350	70Hz	31.47KHz	25.175MHz	VESA Standard
VGA	720 x 400	59.940HZ	31.469KHZ	25.175MHZ	IBM VGA 3H
VGA	640 x 480	60Hz	31.5KHz	25.175MHz	Industry Standard
VGA	640 x 480	72Hz	37.9KHz	31.500MHz	VESA Standard
VGA	640 x 480	75HZ	37.5KHZ	31.500MHZ	VESA Standard
SVGA	800 x 600	60Hz	37.9KHz	40.000MHz	VESA Guidelines
SVGA	800 x 600	72Hz	48.1KHz	50.000MHz	VESA Standard
SVGA	800 x 600	75HZ	46.9KHZ	49.500MHZ	VESA Standard
XGA	1024 x 768	60Hz	48.4KHz	65.000MHz	VESA Guidelines
XGA	1024 x 768	70Hz	56.5KHz	75.000MHz	VESA Standard
XGA	1024 x 768	75HZ	60KHZ	78.750MHZ	VESA Standard
SXGA	1280 x 1024	60Hz	64KHZ	108.000 MHZ	VESA Standard
SXGA	1280 x 1024	75HZ	80KHZ	135.000 MHZ	VESA Standard
WXGA	1280 x 768	60~75Hz	47.7~65KHZ	80.140 MHZ	Not Standard
WXGA	1366 x 768	60~75Hz	47.7~65KHZ	80.000 MHZ	Not Standard
WSXGA	1440 x 900	60~75Hz	65KHZ	150.000 MHZ	Not Standard
WSXGA	1680 x1050	60Hz	70KHZ	150.000 MHZ	Not Standard
UXGA	1600 x1200	60Hz	75KHZ	162.000 MHZ	Not Standard
WUXGA	1920 x1080	60Hz	95KHZ	190.000 MHZ	Not Standard
WUXGA	1920 x1200	60Hz	95KHZ	190.000 MHZ	Not Standard

Notes:

1. All mentioned modes are non-interlaced. The maximum and minimum frame rates are determined by the TFT-LCD.
2. Factory preset modes are overwritten by additional user alignments for automatic recall. The factory preset modes can be recalled at any time.

8.2 LCD Panel & I/O Support

Cosmos is an advanced and general application for a TFT-LCD Monitor Control board. Therefore, the application of this board is not limited to panel manufacturers or models. Furthermore, this board operates with any LVDS interface panel ranging from VGA to WUXGA that can be driven with three or less timing signals. The usual timing signals to a panel are H-sync, V-sync and Data Enable.

For backlight intensity control mechanism, a built-in DC dimming drive signal is installed into the CCFL inverter control port. The CCFL inverter DC power, generally 12V DC, is attached to the same port. Users can design their own key pad board by using OSD & power tact switch as well as a two-color LED. On/off power switch and OSD input signal are detected and executed by the micro controller.

8.4 DVI (Digital Video Interface)

Cosmos has one DVI input port, which complies with VESA DVI standard. Therefore, users can make direct interface to the DVI output of Digital VGA cards. The signal source can be switched through OSD.

High-end Multi-media Display System

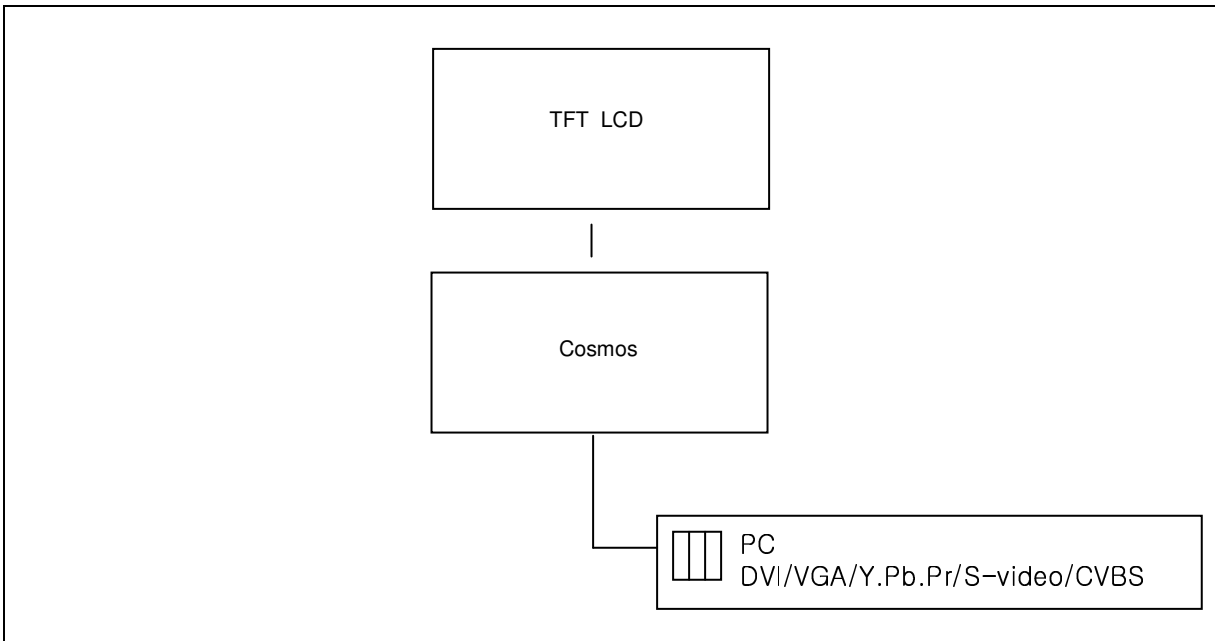

9. OSD (On Screen Display)

9.1 OSD Board Dimension

9.1.1 OSD Board with 6 Buttons

Part number : SGLM0000700

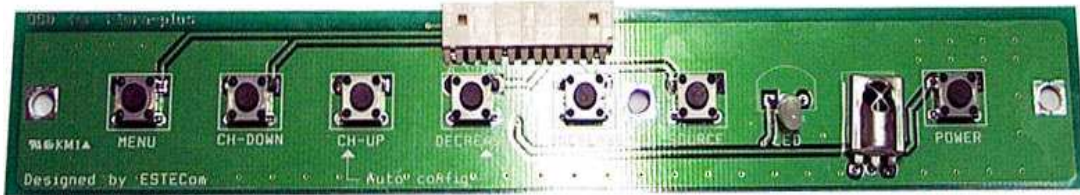

MENU / DOWN / UP / DECREASE(LEFT) / INCREASE(RIGHT) / SOURCE / POWER

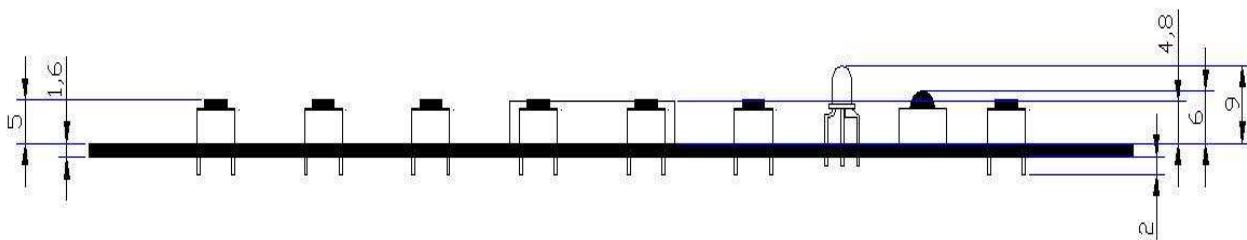
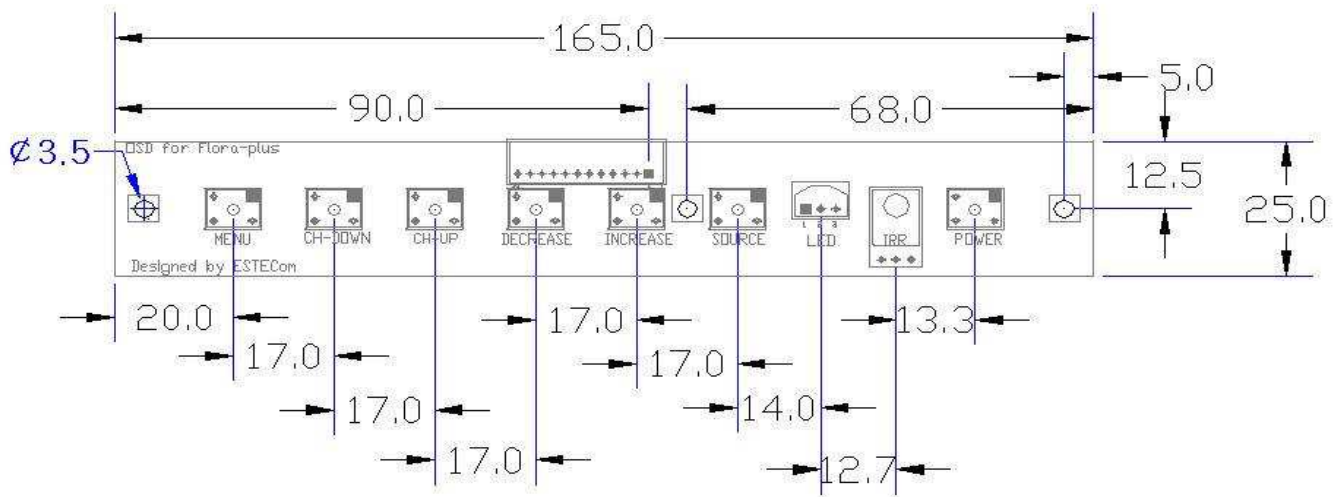

9.2 Summary of OSD Menu

Analog RGB

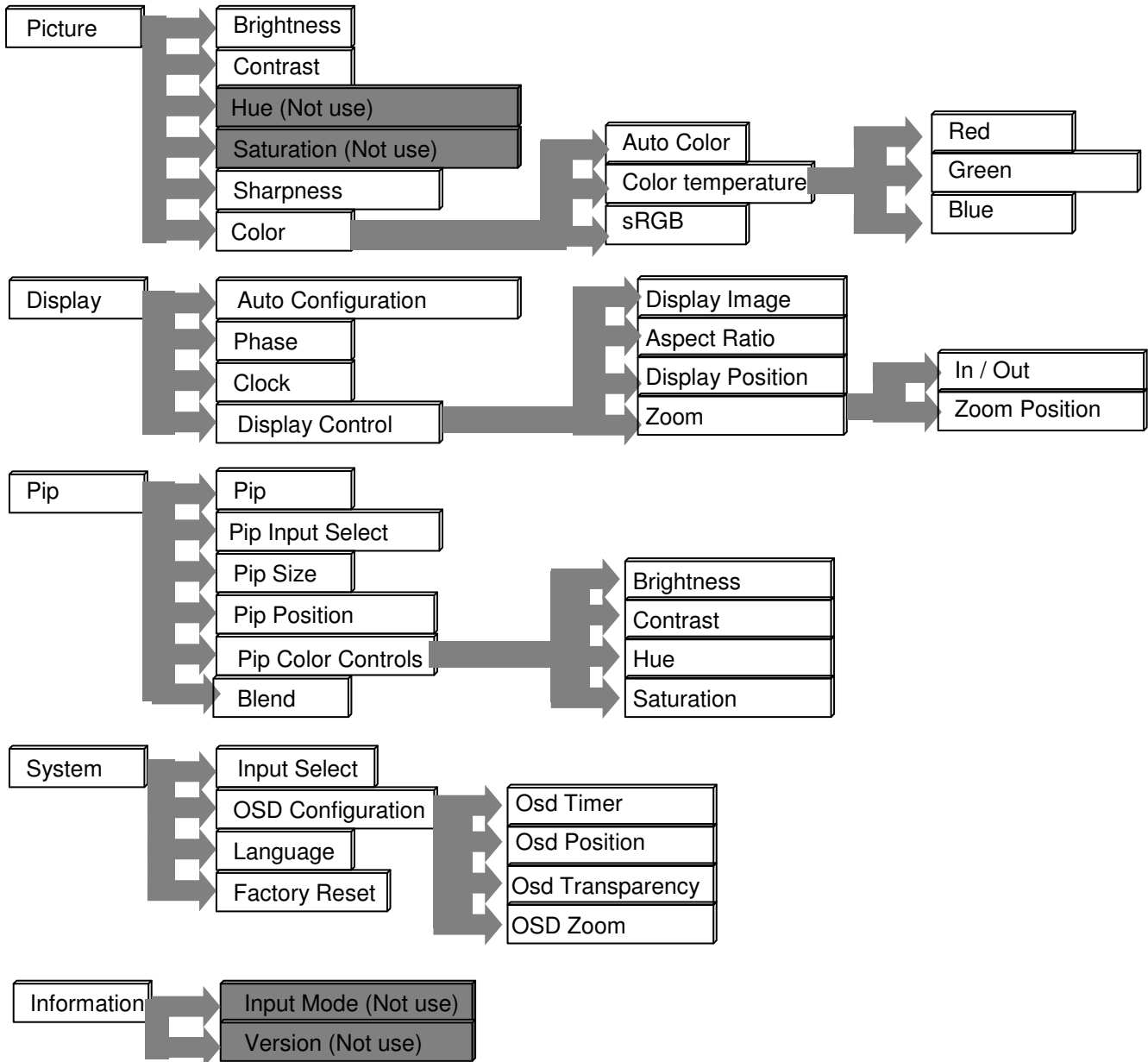

DVI

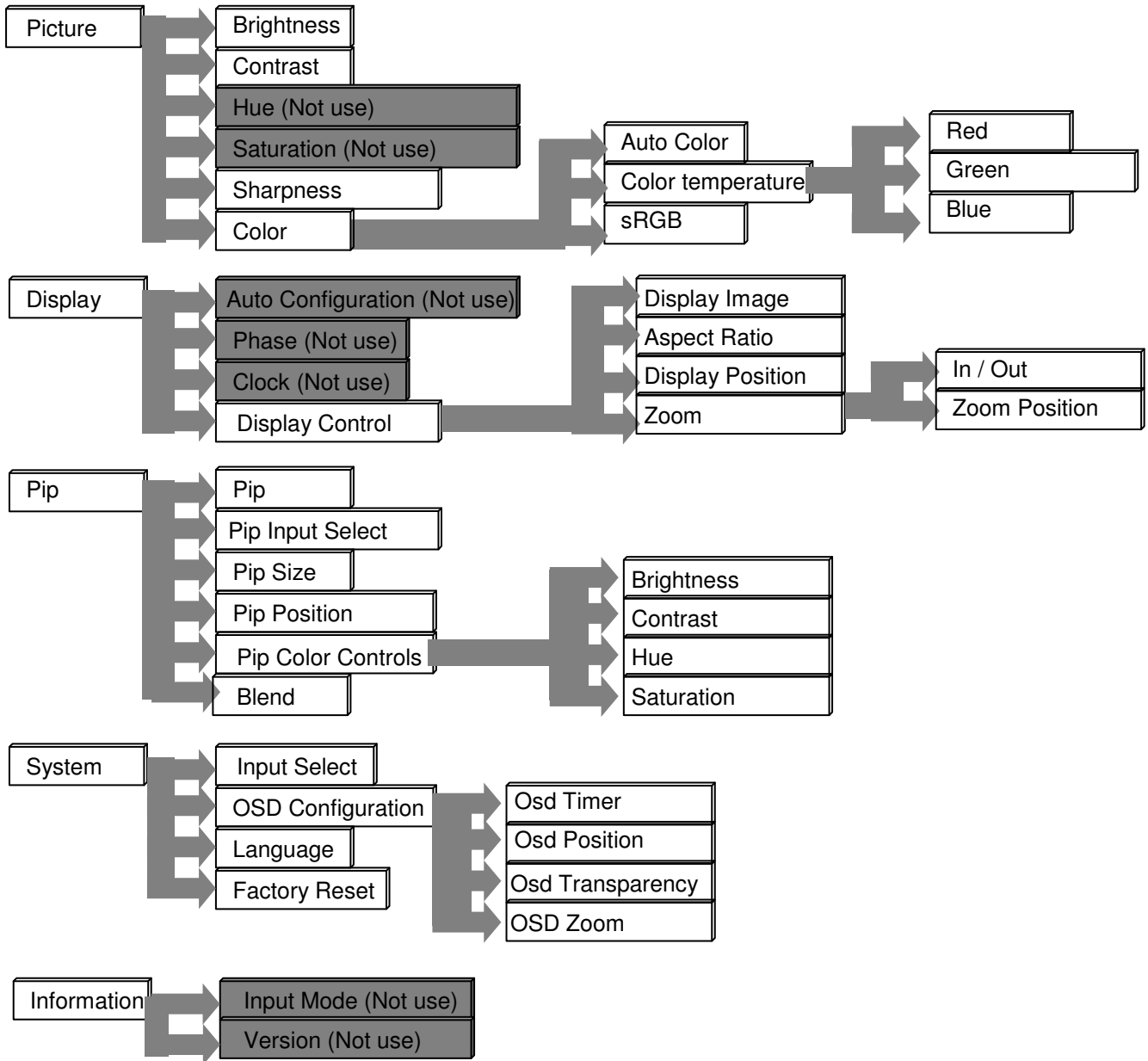

Component

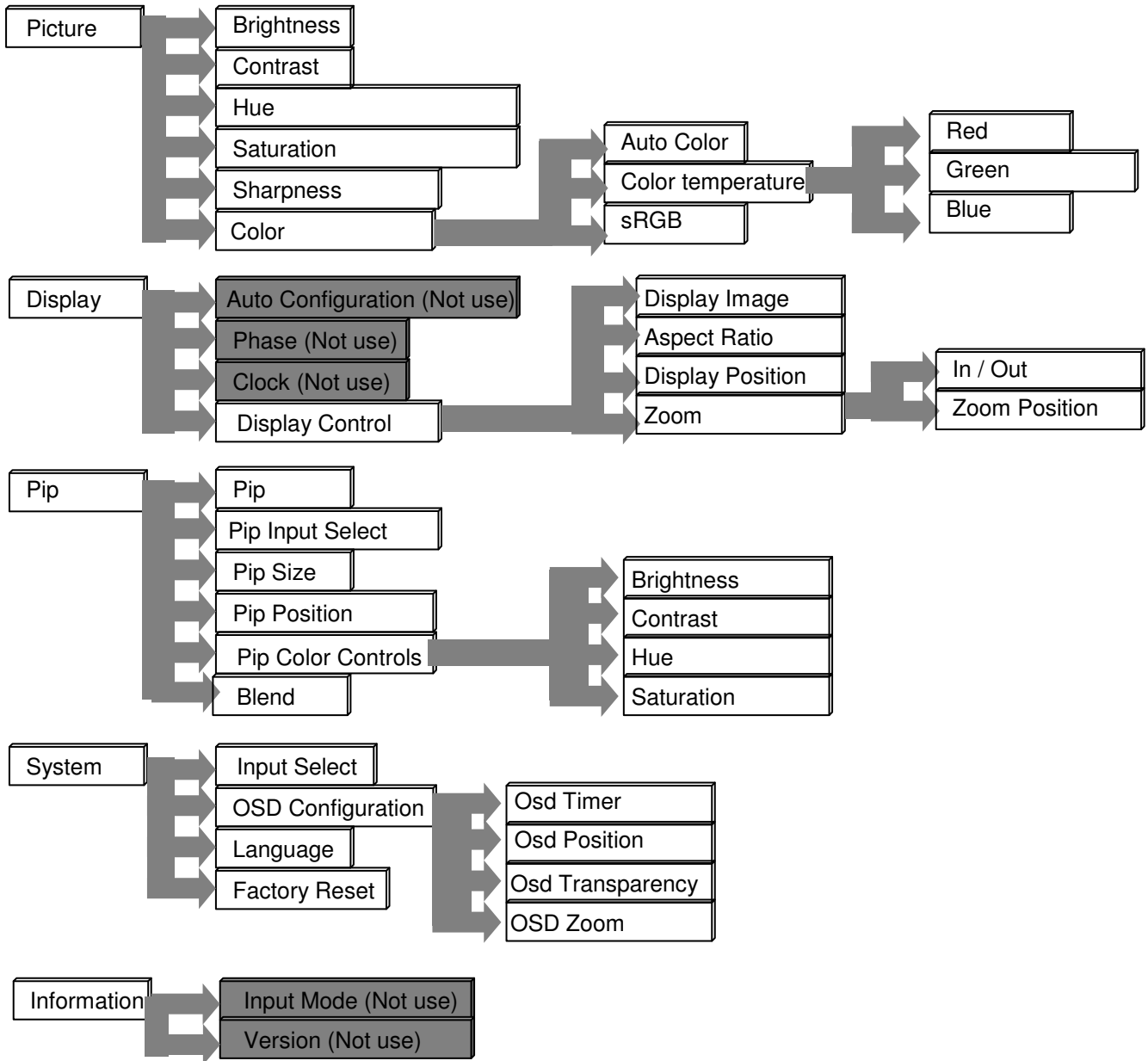

Video / S-video

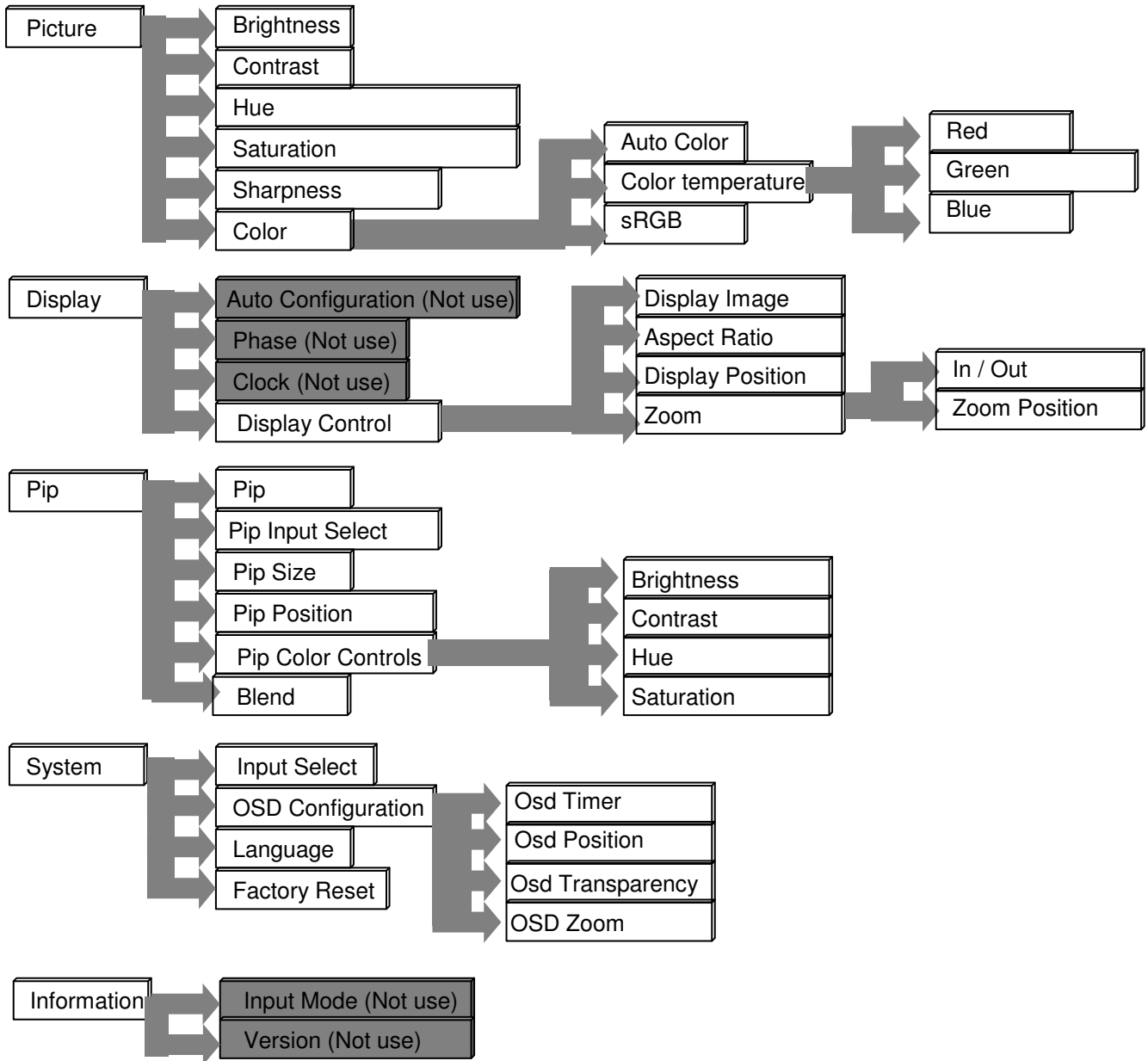

OSD Key Description

- MENU : Menu Key
- DOWN : Down Key (HOT key : Auto Config)
- UP : Up Key
- DECREASE : Decrease Key, Left Key (HOT key : Audio Decrease)
- INCREASE : Increase Key, Right Key (HOT key : Audio Increase)
- SOURCE : Source Select Key (HOT key : Source Select [Analog – Digital])

9.3 OSD Menu enables user to manipulate the image and settings

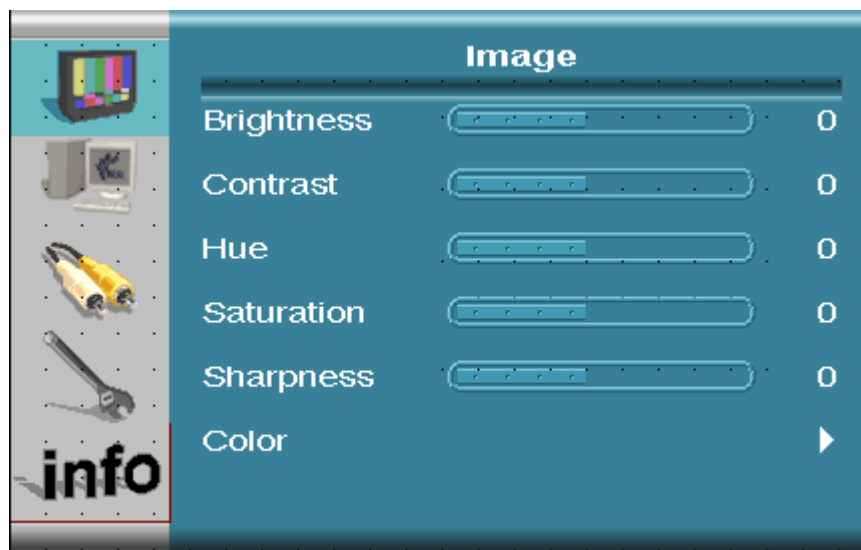

- Brightness : Adjust brightness of the screen (used to pwm control)
- Contrast : Adjust distinction
- Hue : Adjust tint
- Saturation : Adjust color
- Sharpness : Adjust the sharpness

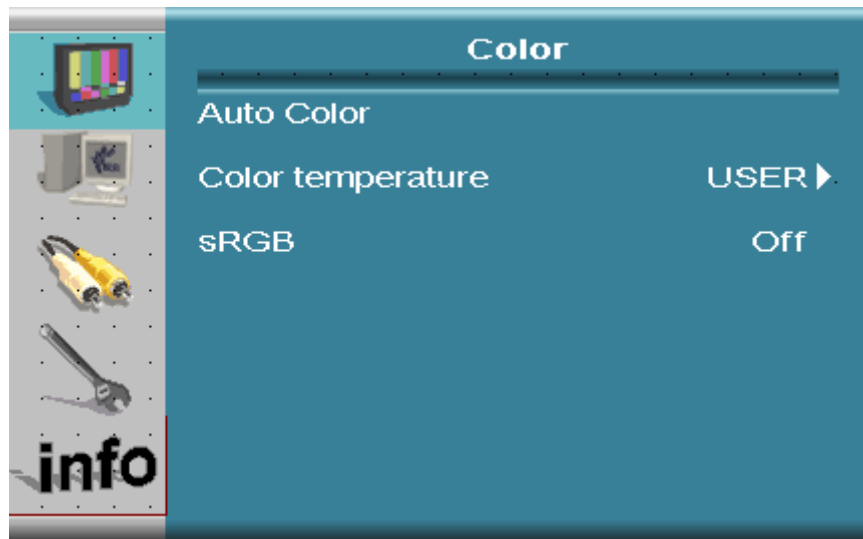

- Auto color : Adjust R,G,B color balance
- Color temperature : Choose various color temperature
- sRGB : Choose using sRGB or not



- Red : Adjust R value of color temperature
- Green : Adjust G value of color temperature
- Blue : Adjust B value of color temperature

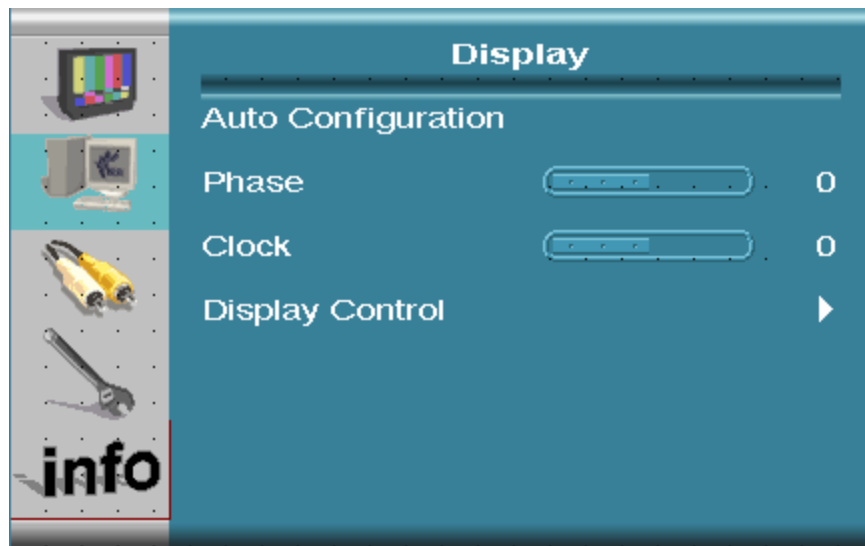

- Auto Configuration : Execute auto adjust for phase, clock, position
- Phase : Adjust the phase of the screen
- Clock : Adjust the horizontal size of the screen



- Display image : Select various display screen
- Aspect ratio : Select display output aspect ratio
- Display Position : Adjust display position

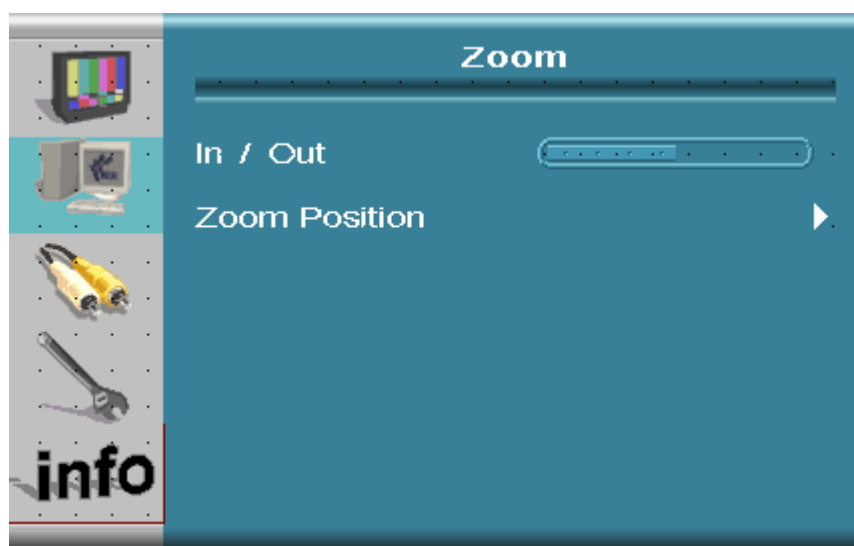

- In / Out : Adjust zoom-in and zoom-out
- Zoom Position : Adjust zoom position

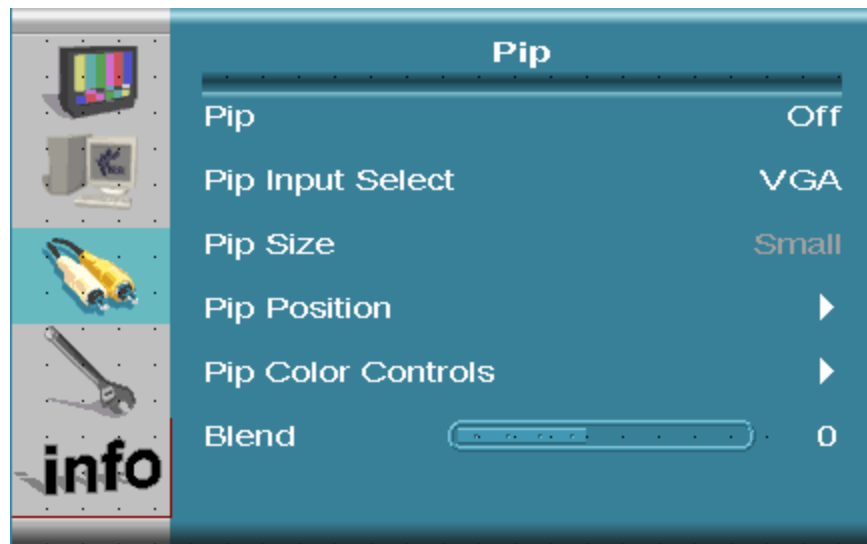

- Pip : Execute PIP (picture in picture)
- Pip Input Select : Select PIP input source
- Pip Size : Select PIP screen size
- Pip Position : Adjust PIP screen Position
- Blend : Adjust PIP screen blending level



- Brightness : Adjust brightness of the PIP screen
- Contrast : Adjust distinction of the PIP screen
- Hue : Adjust tint of the PIP screen
- Saturation : Adjust color of the PIP screen

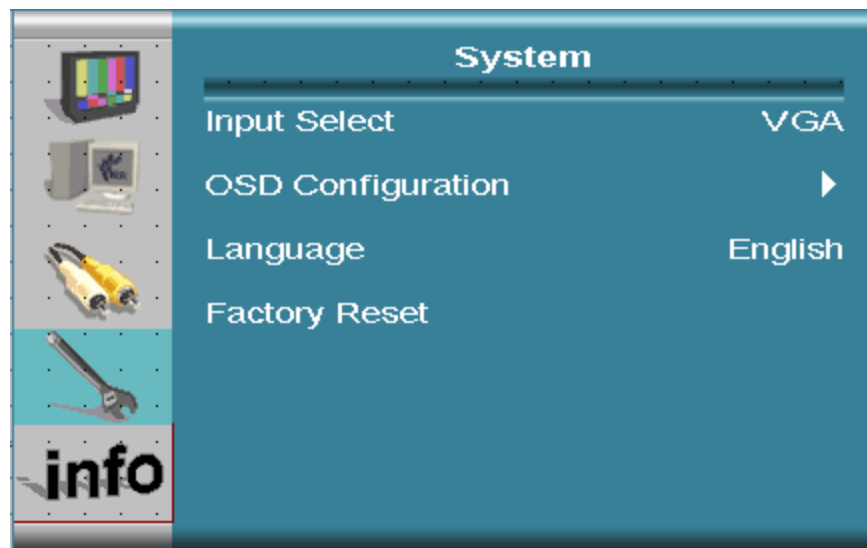

- Input Select : Select input source
- Language : Select various language (Now we support English only)
- Factory Reset : Change set up value to the initial value forwarding at the factory

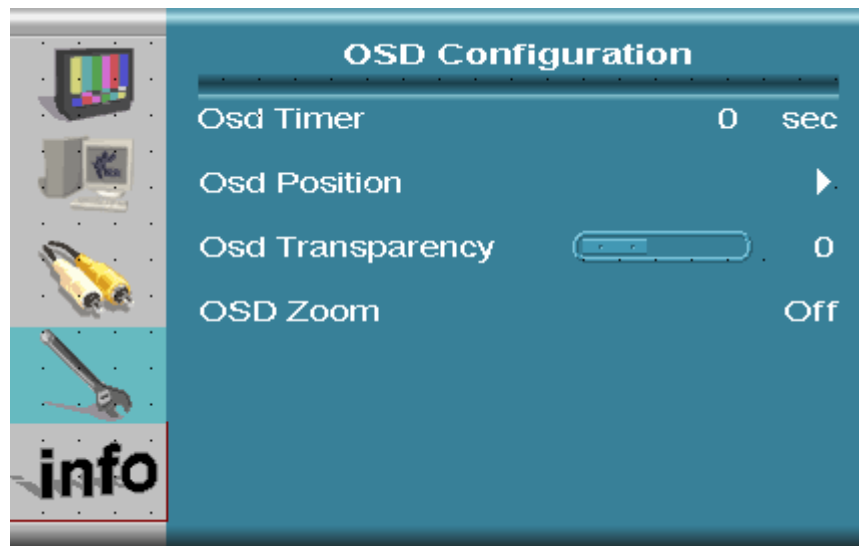

- Osd Timer : Adjust OSD turn-off time
- Osd Position : Adjust OSD position
- Osd Transparency : Choose OSD Transparent level
- Osd Zoom : Choose using OSD zoom or not

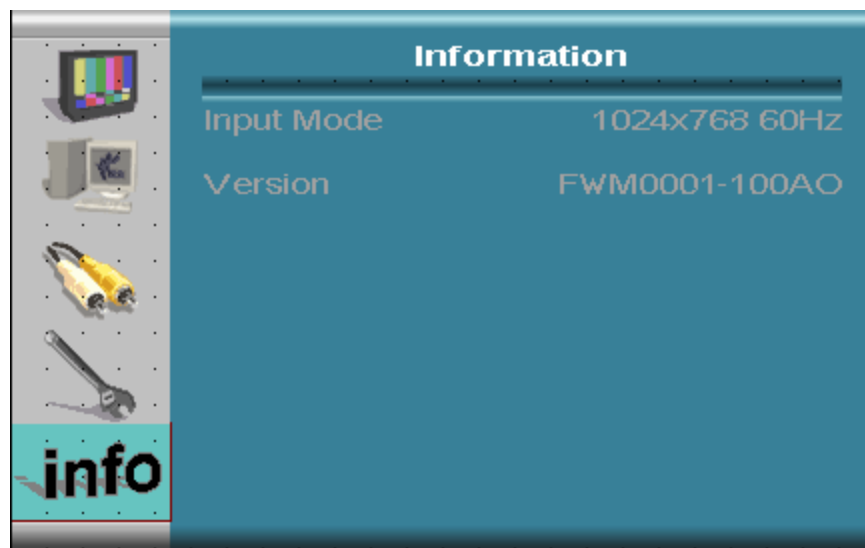

- Input Mode : Display information of the input source
- Version : Display firmware version

DATA SHEET



Model : Audio for COSMOS

Ver. 1.0

MAY 03, 2007

#705, Gunpo Hyundai I Valley, Dang-Dong,
Gunpo-Si, Kyunggi-Do, Korea, 435-010
Tel : 82-31-427-8101
Fax : 82-31-427-8108
Web side: www.estecom.co.kr

CONTENTS

1.	Audio Board Dimension	-----	41
2.	Input Connection	-----	42
3.	Pin configuration	-----	43

The information presented in this document may form a part of quotation or contract under the agreement of both parties. Otherwise, this datasheet is subject to change without prior notice.

1. Audio Board Dimension.

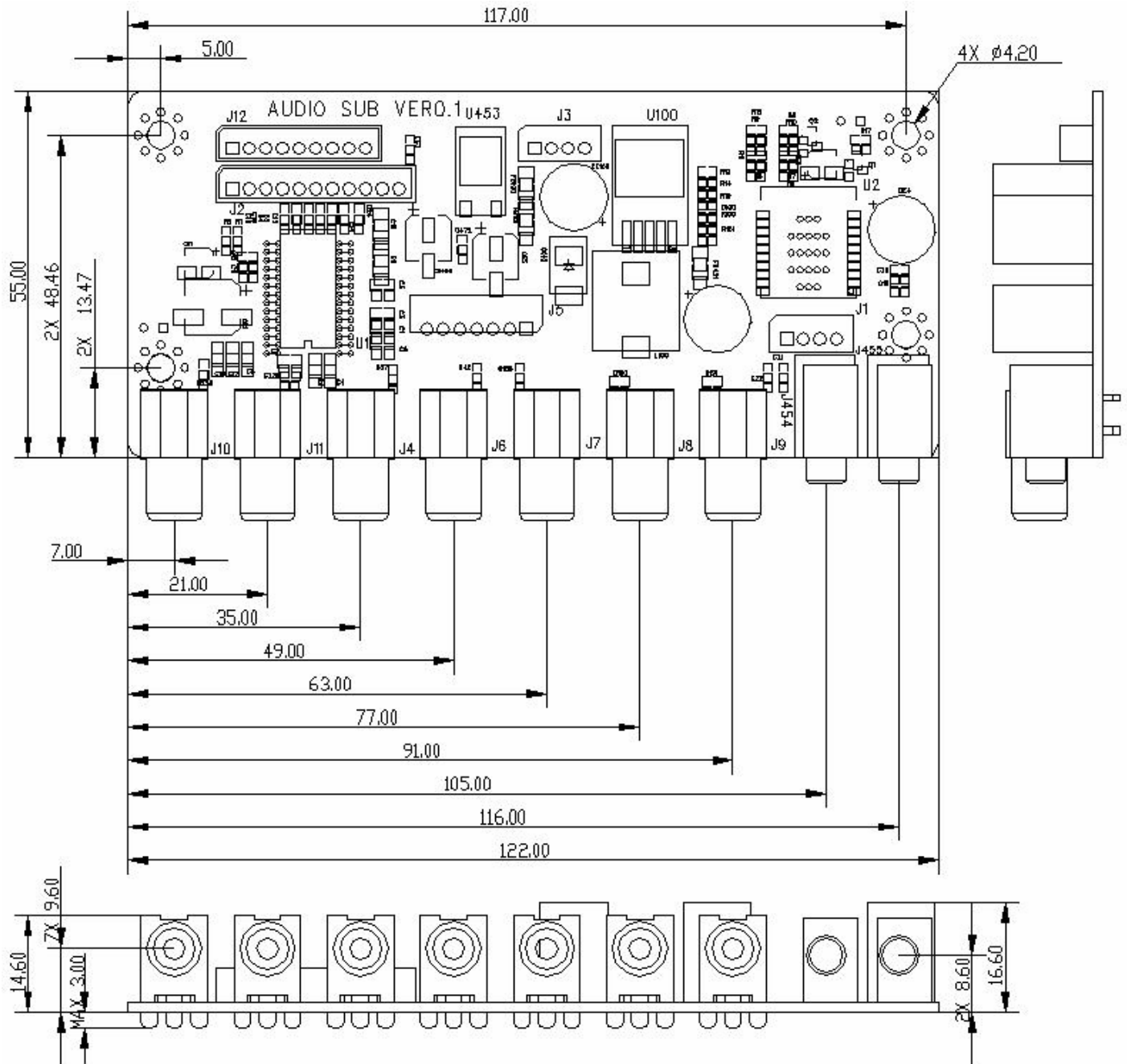

2. Input connection.

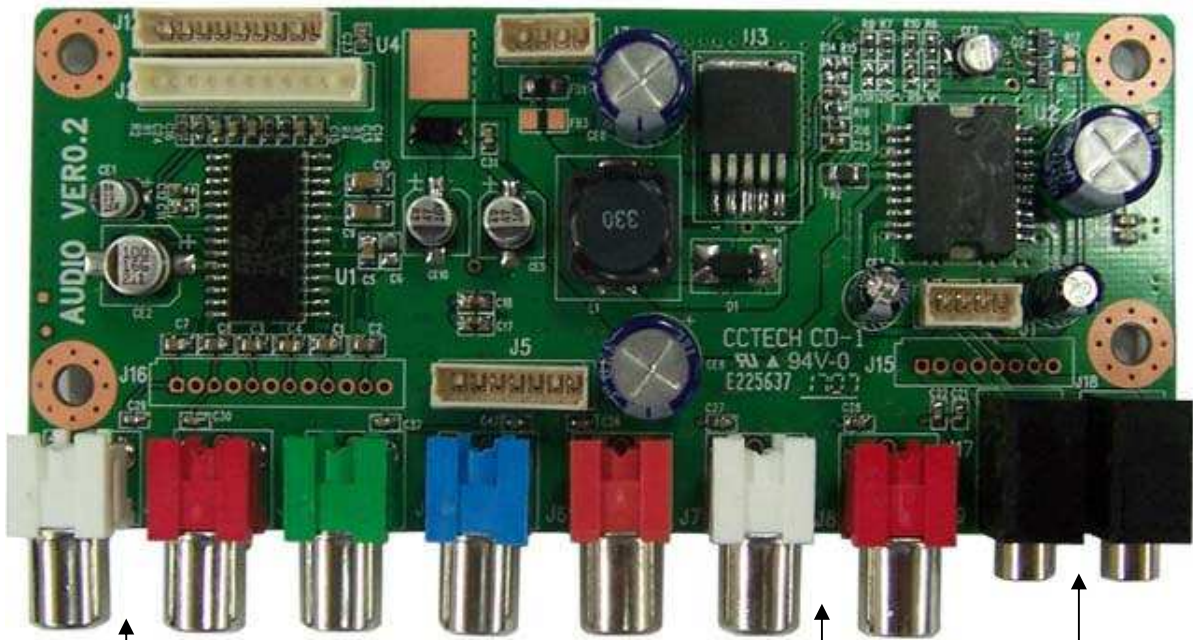

Sound input from Video source

Y/ Pb/ Pr
Component Video

Sound input from Component
Video source

Sound input from PC, Sound output

2. Pin Configuration.

- Component Input Connector

Connector : Molex 53014-0710 (J5)

Pin No.	Symbol	Description	Pin No.	Symbol	Description
1	Pr	Pr	5	Pb	Pb
2	GND	Pr return	6	GND	Pb return
3	Y	Y	7	NC	NC
4	GND	Y return			

- Tuner B'D Connector

Connector : Molex 53014-0910 (J12)

Pin No.	Symbol	Description	Pin No.	Symbol	Description
1	VCC	5V	6	MONO	TV Sound
2	GND	Ground	7	GND	Ground
3	SDA	SDA	8	TV	TV Signal
4	SCL	SCL	9	NC	NC
5	GND	Ground			

- Power Connector

Connector : Molex 53014-0410 (J3)

Pin No.	Symbol	Description	Pin No.	Symbol	Description
1	VCC	AMP POWER	3	GND	Ground
2	VCC	AMP POWER	4	GND	Ground

- Main B'D Control & Signal Connector
Connector : 53014-1110 made by Molex (J2)

Pin No.	Symbol	Description	Pin No.	Symbol	Description
1	VCC	5V	7	GND	Ground
2	GND	Ground	8	VOL_H	Volume control H
3	SDA	SDA	9	VOL_L	Volume Control L
4	SCL	SCL	10	MUTEN	AMP Mute
5	GND	Ground	11	STBYN	AMP STBYN
6	TV	TV Signal			

- Sound Out Connector
Connector : 53014-1210 made by Molex(J16)

Pin No.	Symbol	Description	Pin No.	Symbol	Description
1	VIDEO L	Video Left Sound	7	COM R	Component Right Sound
2	GND	Ground	8	GND	Ground
3	VIDEO R	Video Right Sound	9	PC L	PC Left Sound
4	GND	Ground	10	GND	Ground
5	COM L	Component Left Sound	11	PC R	PC Right Sound
6	GND	Ground	12	GND	Ground

- Headphone Out Connector
 Connector : 53014-0810 made by Molex(J15)

Pin No.	Symbol	Description	Pin No.	Symbol	Description
1	HP_OUT R	Headphone R Out	5	HP_RET R	Headphone return R
2	GND	Ground	6	GND	Ground
3	HP_OUT L	Headphone L Out	7	HP_RET L	Headphone return L
4	GND	Ground	8	GND	Ground

- Speaker Out Connector
 Connector : 53014-0410 made by Molex(J1)

Pin No.	Symbol	Description	Pin No.	Symbol	Description
1	SP_R-	Speaker R -	3	SP_L+	Speaker L +
2	SP_R+	Speaker R +	4	SP_L-	Speaker L -