

DATA SHEET



Model : ORCHID-S

Ver. 0.2

May 16, 2011

#705, Gunpo Hyundai I Valley, Dang-Dong,
Gunpo-Si, Kyunggi-Do, Korea, 435-010
Tel : 82-31-427-8101
Fax : 82-31-427-8108
Web side: www.estecom.co.kr

CONTENTS

1.	Revisions of History	-----	3
2.	General Descriptions	-----	4
3.	Features	-----	4
4.	Block Diagram	-----	5
5.	Outline Dimensions	-----	6
6.	Connectors Information	-----	9
7.	Reference Data	-----	15
8.	Supported Input Formats	-----	16
9.	On Screen Display	-----	18

The information presented in this document may form a part of quotation or contract under the agreement of both parties. Otherwise, this datasheet is subject to change without prior notice.

1. Revisions of History

Revision No.	Date	Page	Description
Ver. 0.1	Feb. '11	All	First Draft, Preliminary Specification
Ver. 0.2	May. '11	All	Update all board dimension

2. General Descriptions

Orchid-S is an advanced TFT-LCD Monitor Control Board. This design enables a full conventional CRT monitor and/or video replacement with a large size Active Matrix LCD module. It is suitable for video resolution up to WUXGA @ 60Hz in all video modes, the full display area of the module is used. The design is implemented as a single printed circuit board.

3. Features

- Designed to give state-of-the-art picture quality
- Analog RGB / DVI / HDMI / YPbPr / CVBS / S-video / with Audio In & Speaker Out(10W x 2).
- Optional input combination, e.g., PC monitor only
- Full CRT multi-sync monitor compatibility
- Multi-sync capability up to WUXGA resolution @ 60Hz, compatible standard SVGA, XGA and SXGA VESA timing.
- Expand DOS,VGA,SVGA,XGA, SXGA and WUXGA to full screen display
- Single control operated & transparent On-Screen-Display (hereafter 'OSD') user interface
- Full control of all relevant display and interface parameters via OSD
- VESA DDC 1/2B compliant
- Compatible with VESA DPMS power saving modes
- Form factor
 - Orchid-S Board -> 105mm (L) x 150mm (W) x 12mm(H)
 - Input connecting Board -> 35mm(L) x 212mm(W) x 29.1mm(H)
- +12VDC ~ +24VDC Single power input.
- Operating temperature: 0°C to 50°C
- The IR ,UART & RS232 function (full remote control)integrated.

4. Block Diagram

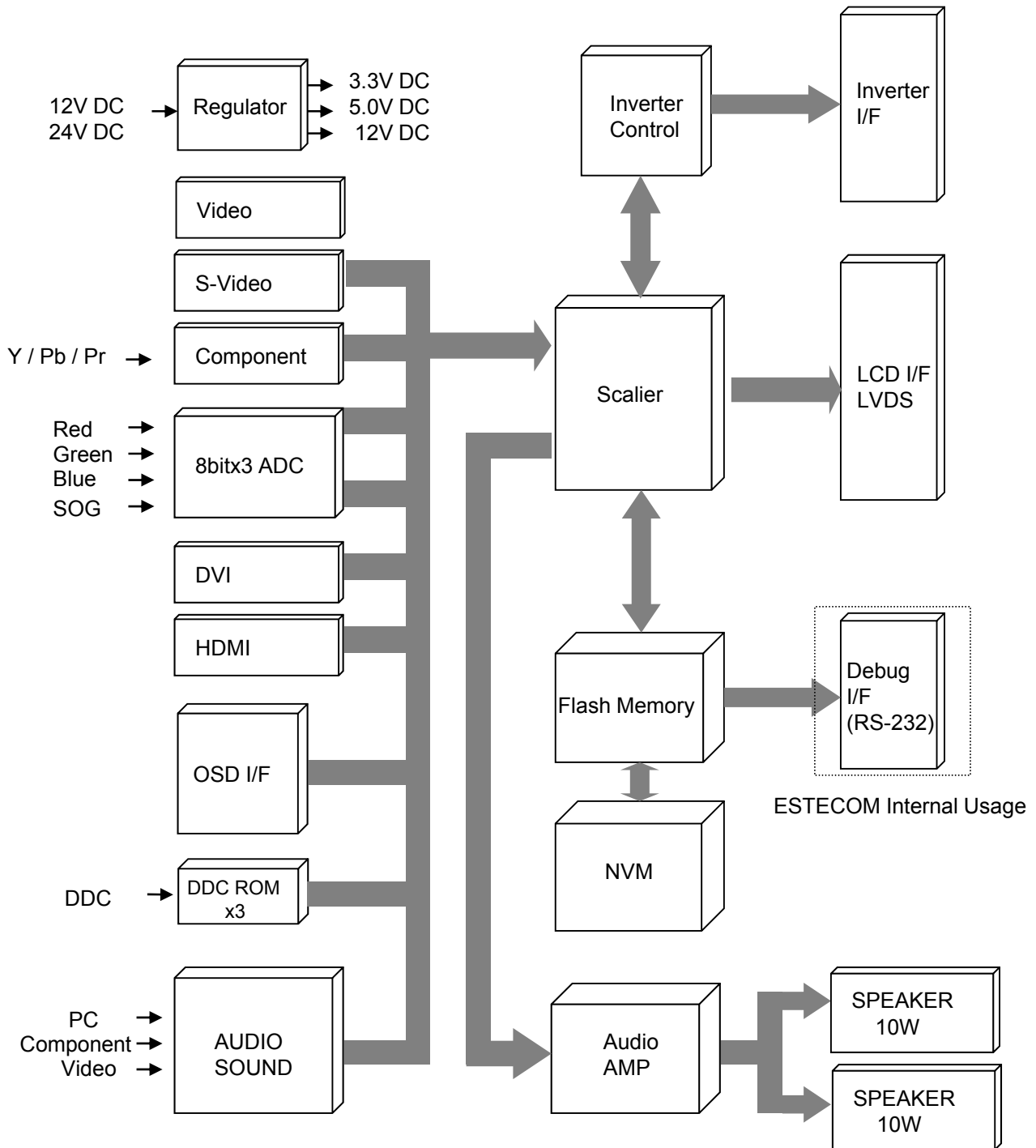

5. Outline Dimensions

5.1 Low profile Connectors

- Dimension : 105mm (L) x 150mm (W) x 12mm(H)

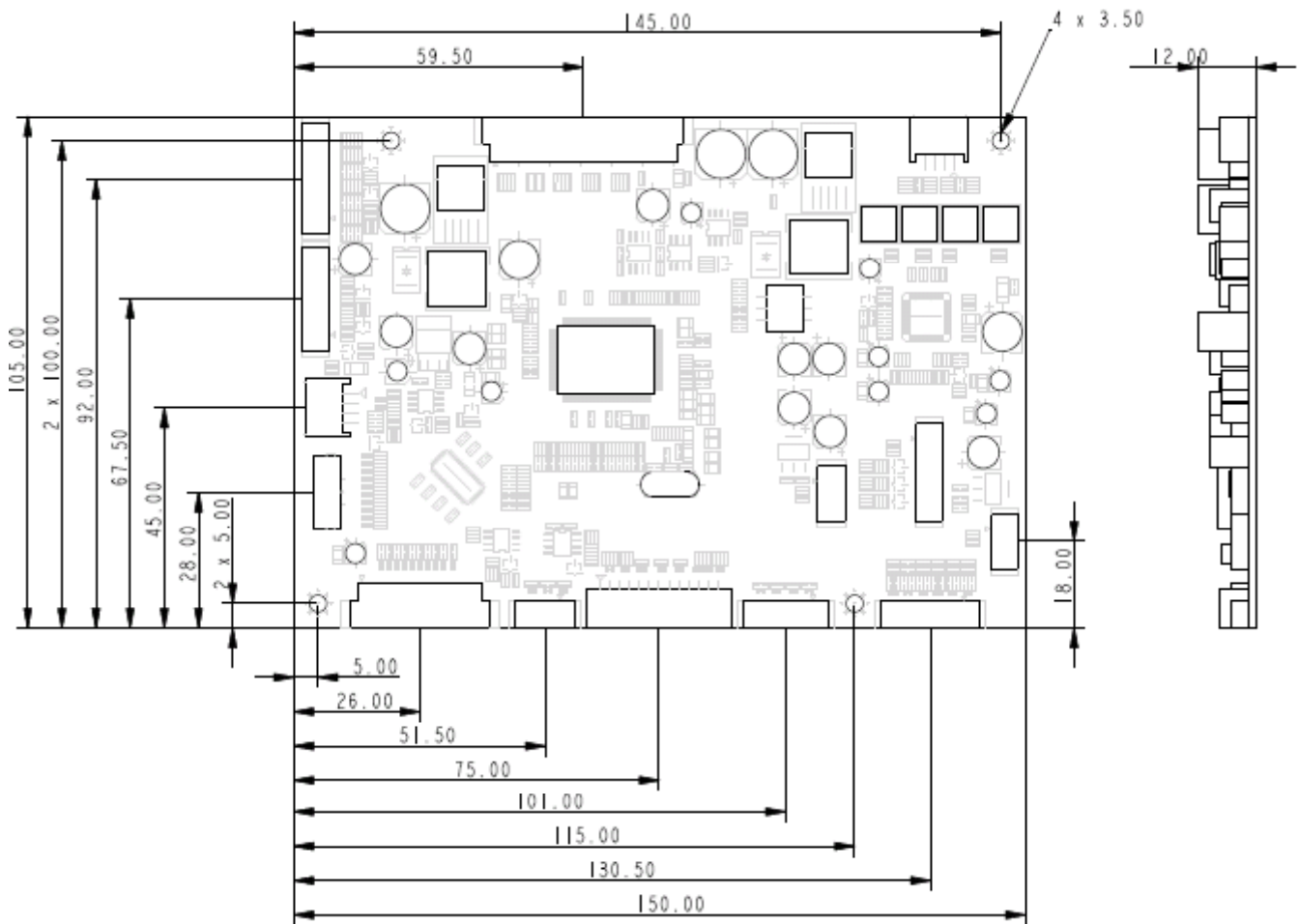

5.1.1 Actual connectors location

- Analog, DVI, HDMI, Y Pb Pr, Video, S-Video

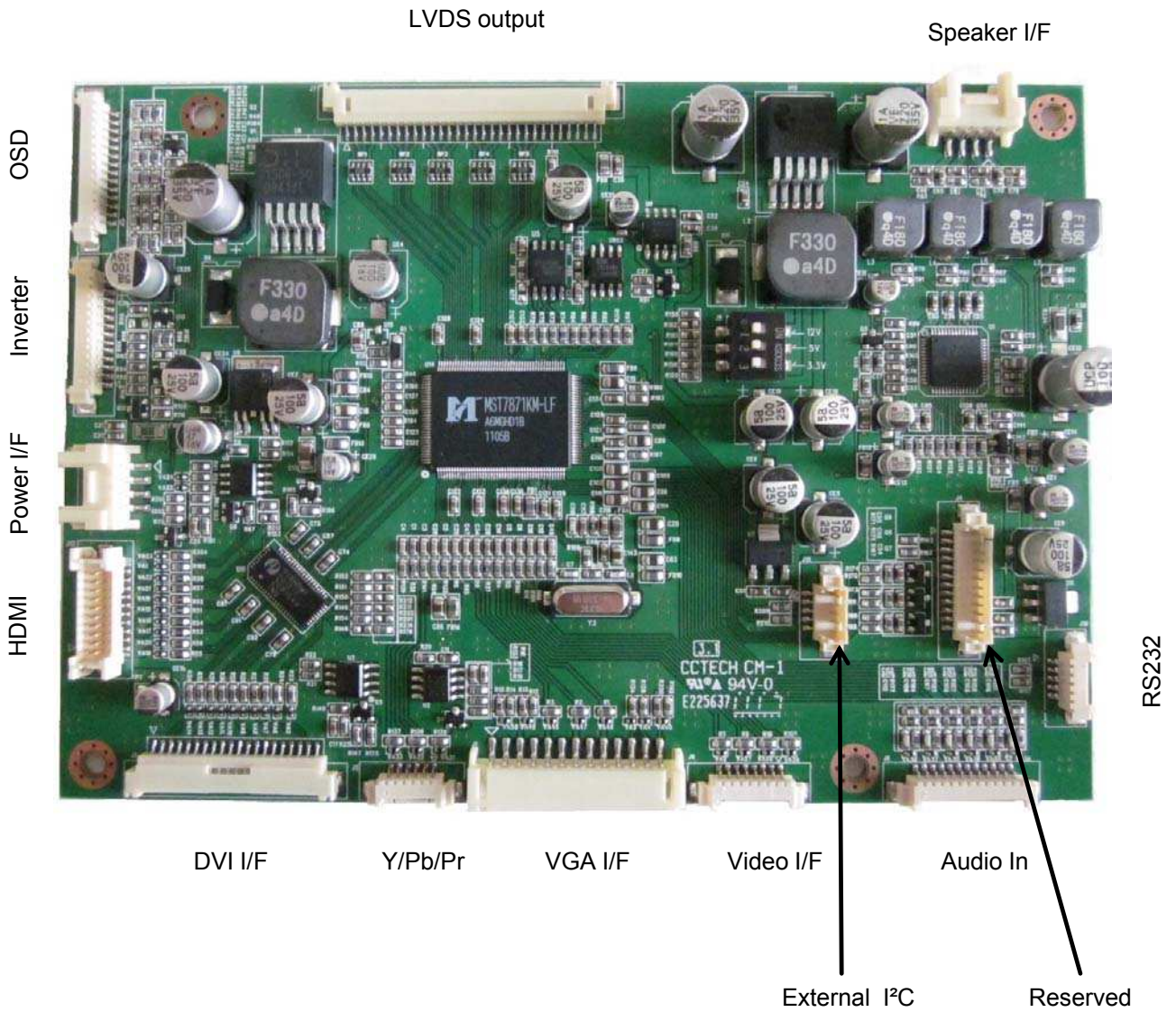

5.2 Input board for Orchid-S

- Dimension : 35mm (L) x 212mm (W) x 29.1mm(H)

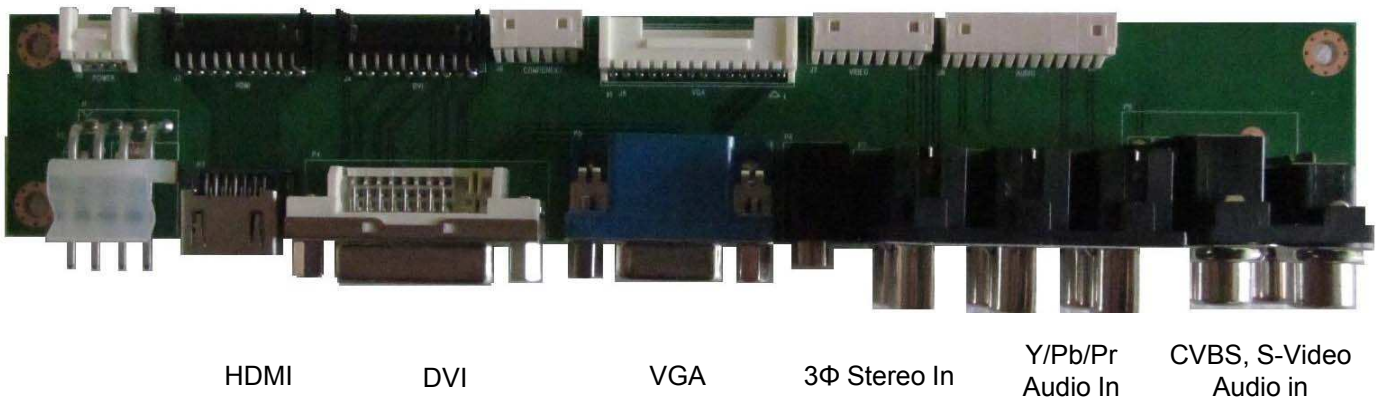
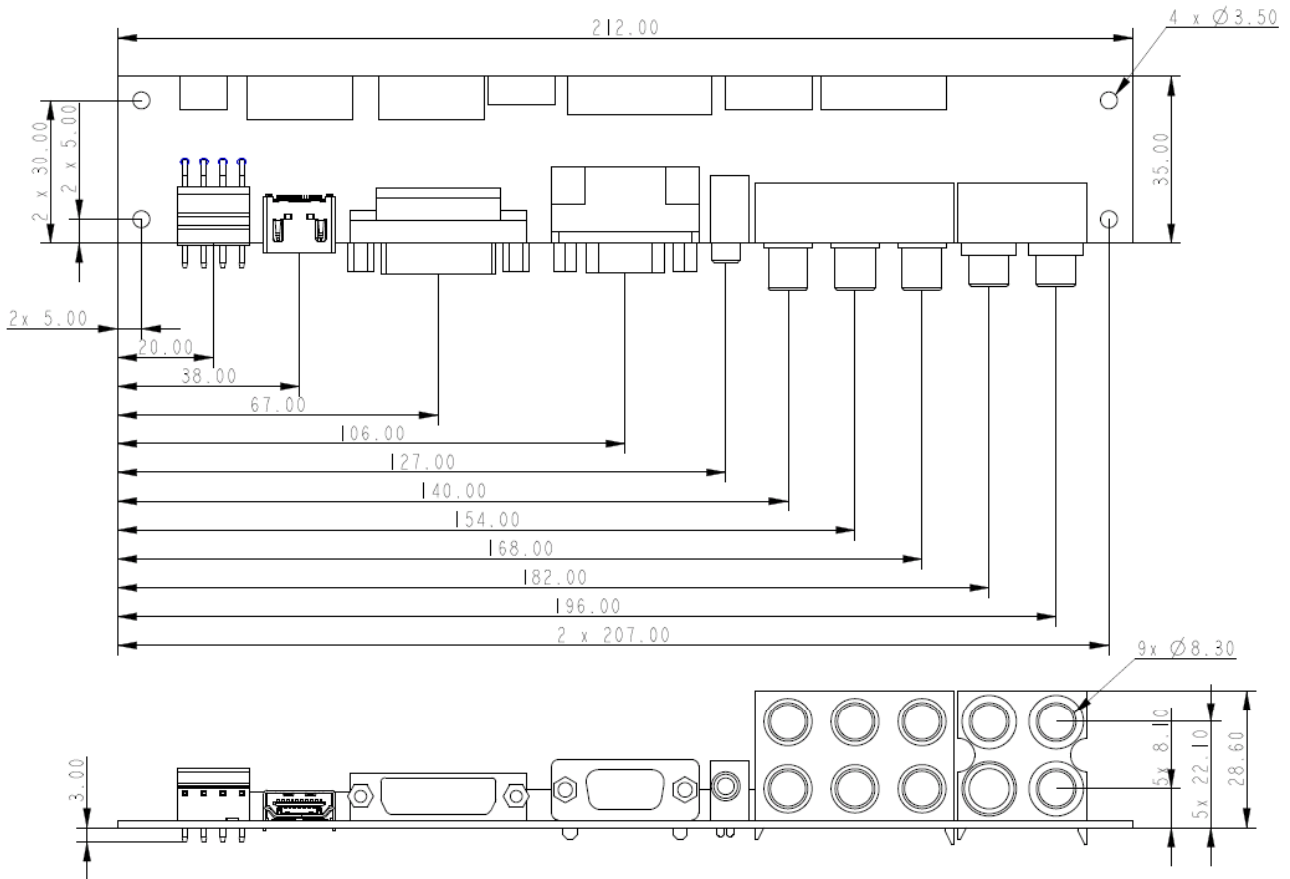

6. Connectors Information

6.1 Input Connectors

- Power Input Connector

Connector : Yeonho 20037WR5-04 (J18)

Pin No.	Symbol	Description	Pin No.	Symbol	Description
1	Vin	+12~24V DC	2	Vin	+12~24V DC
3	Vin	Ground	4	Vin	Ground

- HDMI Input Connector

Connector : Hirose DF13-20DP-1.25V (J12)

Pin No.	Symbol	Pin No.	Symbol	Pin No.	Symbol
1	HDMI Data2+	8	Ground	15	DDC Serial Clock
2	Ground	9	HDMI Data0-	16	DDC Serial Data
3	HDMI Data2-	10	HDMI Clock+	17	Ground
4	HDMI Data1+	11	Ground	18	Bus Power(+5V)
5	Ground	12	HDMI Clock-	19	Hot Plug Detect
6	HDMI Data1-	13	C.E.C	20	N/C
7	HDMI Data0+	14	N/C		

● DVI-D Input Connector

Connector : Yeonho 12507WR-20 (J5)
Lock type

Pin No.	Symbol	Pin No.	Symbol	Pin No.	Symbol
1	Ground	8	Hot Plug Detect	15	DDC Serial Data
2	T.M.D.S Clock-	9	Ground	16	DDC Serial Clock
3	T.M.D.S Clock+	10	Bus Power(+5V)	17	Ground
4	Ground	11	Ground	18	T.M.D.S Data2-
5	T.M.D.S Data0-	12	T.M.D.S Data1-	19	T.M.D.S Data2+
6	T.M.D.S Data0+	13	T.M.D.S Data1+	20	Ground
7	N/C	14	Ground		

● Component Input Connector

Input Connector : Yeonho 12505WR-6 (J2)

Pin No.	Symbol	Description	Pin No.	Symbol	Description
1	Pr	Component Red	4	GND	Ground
2	GND	Ground	5	Pb	Component Blue
3	Y	Component Green	6	GND	Ground

● Analog RGB Input Connector

Connector : JST S13B-PH-SM3-TB (J1)

Pin No.	Symbol	Description	Pin No.	Symbol	Description
1	CONNECT	VGA Detect	8	BGND	Blue Return
2	SDA	DDC Serial Data	9	BLUE	Blue Input
3	SCL	DDC Data Clock	10	N/C	No Connection
4	RGND	Red Return	11	VSYNC	Vertical Sync
5	RED	Red Input	12	GND	Ground
6	GGND	Green Return	13	HSYNC	Horizontal Sync
7	GREEN	Green Input			

● Video Input Connector

Input Connector : Yeonho 12505WR-8 (J9)

Pin No.	Symbol	Description	Pin No.	Symbol	Description
1	CVBS 2	Composite Video	5	Y-IN	Luminance (S-Video)
2	GND	Ground	6	GND	Ground
3	CVBS1	Composite Video	7	C-IN	Chroma (S-Video)
4	GND	Ground	8	GND	Ground

● Sound Input Connector

Input Connector : Yeonho 12505WR-12 (J6)

Pin No.	Symbol	Description	Pin No.	Symbol	Description
1	COM-R	Component Right	7	AV-L	Video Left
2	GND	Ground	8	GND	Ground
3	COM-L	Component Left	9	PC-R	RGB Right
4	GND	Ground	10	GND	Ground
5	AV-R	Video Right	11	PC-L	RGB Left
6	GND	Ground	12	GND	Ground

● OSD, LED Interface Connector :

Input Connector : Yeonho 12505WR-14 (J3)

Pin No.	Symbol	Description	Pin No.	Symbol	Description
1	Vcc	+5V	8	KEY 3	Increase
2	GND	Ground	9	KEY 7	Menu
3	KEY 5	Up	10	GND	Ground
4	KEY 6	Down	11	KEY 1	Power
5	KEY 4	Decrease	12	GND	Ground
6	IR	IR	13	LED 0	LED 0
7	KEY 2	Source/Exit	14	LED 1	LED 1



● Debug Connector :

Connector : Yeonho 12505WR-05 (J10)

Pin No.	Symbol	Description
1	GND	Ground
2	Rx	TxD
3	Tx	RxD
4	VCC	+5V DC
5	GND	Ground

● Temperature Sensor Connector

Input Connector : Yeonho 12505WS-12 (J4)

Pin No.	Symbol	Description	Pin No.	Symbol	Description
1	Vcc	+5V	7	FAN2	FAN ON2
2	GND	Ground	8	FAN1	FAN ON1
3	SDA	Serial Data	9	GND	Ground
4	SCL	Serial Clock	10	GND	Ground
5	TEMP	Temperature Sensor	11	Vin	+12~24V DC
6	FAN3	FAN ON3	12	Vin	+12~24V DC

● Light Sensor Connector

Input Connector : Yeonho 12505WS-5 (J16)

Pin No.	Symbol	Description
1	Vcc	+5V
2	SDA	Serial Data
3	LIGHT	Light Sensor
4	SCL	Serial Clock
5	GND	Ground

6.2 Output Connectors

- LVDS Output Connector

Connector : Yeonho 12507WR-30 (J7)

Pin No.	Symbol	Pin No.	Symbol
1	TX0- E	16	TX1+ O
2	TX0+ E	17	GND
3	TX1- E	18	TX2- O
4	TX1+ E	19	TX2+ O
5	GND	20	TXCLK- O
6	TX2- E	21	TXCLK+ O
7	TX2+ E	22	TX3- O
8	TXCLK- E	23	TX3+ O
9	TXCLK+ E	24	GND
10	TX3- E	25	3.3V (LVDS option)
11	TX3+ E	26	GND
12	GND	27	VCC
13	TX0- O	28	VCC
14	TX0+ O	29	VCC
15	TX1- O	30	VCC

- Backlight Power Connector :

Connector : Yeonho 12505WR-13 (J11)

Pin No.	Symbol	Description	Pin No.	Symbol	Description
1	GND	Ground	8	N/C	No Connect
2	VCC	+12~24V DC	9	VCC	+12~24V DC
3	N/C	+5V DC	10	VCC	+12~24V DC
4	N/C	No Connect	11	GND	Ground
5	N/C	No Connect	12	GND	Ground
6	ON/OFF	Back-light On/Off	13	N/C	No Connect
7	BRIGHT	Brightness Adjustment			

- Speaker Output Connector

Connector : Yeonho 20037WR-04 (J13)

Pin No.	Symbol	Description	Pin No.	Symbol	Description
1	R+	Speaker Right+	2	R-	Speaker Right-
3	L+	Speaker Left+	4	L-	Speaker Left-

7. Reference Data

Video Input Timing;

Supported vertical refresh rates for each modes are as follows:

640 x 350	70Hz
640 x 400	70Hz
700 x 560	55~75Hz
720 x 350	70Hz
720 x 400	70Hz
640 x 480	60~75Hz
800 x 600	60~75Hz
1024 x 768	60~75Hz
1152 x 864	60~75Hz
1280 x 1024	60~75Hz
1280 x 768	60~75Hz
1366 x 768	60~75Hz
1440 x 900	60~75Hz
1600 x 1200	60~75Hz
1680 x 1050	60~75Hz
1920 x 1080	60Hz

Sync. : H/V Separated TTL, Composite Sync

● Electrical Parameters

Reference Orchid-S, t_A 25 ° C

Symbol	Description	Min	Type	Max	Unit
V_{DD}	DC Power Supply	11.2	12 ~24	24.8	V
$V_{i(RGB)}$	Video Input Signal (w.r.t. GND)	0.5	0.7	1.0	V_{PP}
f_S	Video Sample Rate			80	MHz
f_{HS}	Horizontal Sync. Frequency	30		60	KHz
f_{vs}	Vertical Sync Frequency	56		75	Hz
F_{SIH}	Sync Input High Level	2.5			V
V_{SIL}	Sync Input Low Level			0.8	VDC
I_{DD2}	Supply Current +12V (with LCD & Inverter)			3.5	A

Note 1. Power consumption measuring condition is 2 pixel check board pattern @ SXGA 75Hz and maximum brightness with Samsung LTM170E4 & inverter at t_A 25°C.

8. Supported Input Formats

8.1 Video Mode Support

The Orchid-S series can support any video mode within the following input constraints:

- Signal sample frequency with the input $\leq 80\text{MHz}$
- Horizontal sync frequency between 30KHz and 80KHz

The modes are detected with the presentation of the input and previous alignments for setup are Automatically recalled. The emulation of a true multi-sync monitor is implemented.

The factory preset supported modes are as follows:

Mode	Resolution	Refresh rate	H-freq.	Pixel freq.	Remarks
VGA	640 x 350	70Hz	31.47KHz	25.175MHz	VESA Standard
VGA	720 x 400	59.940HZ	31.469KHZ	25.175MHZ	IBM VGA 3H
VGA	640 x 480	60Hz	31.5KHz	25.175MHz	Industry Standard
VGA	640 x 480	72Hz	37.9KHz	31.5MHz	VESA Standard
VGA	640 x 480	75HZ	37.5KHZ	31.5MHZ	VESA Standard
SVGA	800 x 600	60Hz	37.9KHz	40 MHz	VESA Guidelines
SVGA	800 x 600	72Hz	48.1KHz	50 MHz	VESA Standard
SVGA	800 x 600	75HZ	46.9KHZ	49.5MHZ	VESA Standard
XGA	1024 x 768	60Hz	48.4KHz	65 MHz	VESA Guidelines
XGA	1024 x 768	70Hz	56.5KHz	75 MHz	VESA Standard
XGA	1024 x 768	75HZ	60KHZ	78.75MHZ	VESA Standard
SXGA	1280 x 1024	60Hz	64KHZ	108 MHZ	VESA Standard
SXGA	1280 x 1024	75HZ	80KHZ	135 MHZ	VESA Standard
WXGA	1280 x 768	60~75Hz	47.7~65KHZ	80.14 MHZ	Not Standard
WXGA	1366 x 768	60~75Hz	47.7~65KHZ	80 MHZ	Not Standard
WSXGA	1440 x 900	60~75Hz	58KHZ	135 MHZ	Not Standard
WSXGA+	1680 x1050	60Hz	62KHZ	140 MHZ	Not Standard
UXGA	1600 x1200	60Hz	62KHZ	133 MHZ	Not Standard
WUXGA	1920 x1080	60Hz	69KHZ	166 MHZ	

Notes:

1. All mentioned modes are non-interlaced. The maximum and minimum frame rates are determined by the TFT-LCD.
2. Factory preset modes are overwritten by additional user alignments for automatic recall. The factory preset modes can be recalled at any time.

8.2 LCD Panel & I/O Support

Orchid-S is an advanced and general application for a TFT-LCD Monitor Control board. Therefore, the application of this board is not limited to panel manufacturers or models. Furthermore, this board operates with LVDS interface panel ranging from VGA to WUXGA that can be driven with three or less timing signals. The usual timing signals to a panel are H-sync, V-sync and Data Enable.

For backlight intensity control mechanism, a built-in DC dimming drive signal is installed into the CCFL Inverter or LED driver control port.

The CCFL inverter & LED driver DC power, generally 12V DC, is attached to the same port. Users can design their own key pad board by using OSD & power tact switch as well as a two-color LED.

On/off power switch and OSD input signal are detected and executed by the micro controller.

9. OSD (On Screen Display)

9.1 OSD Board Dimension

9.1.1 OSD Board with 6 Buttons

Part number : SGLM0000600

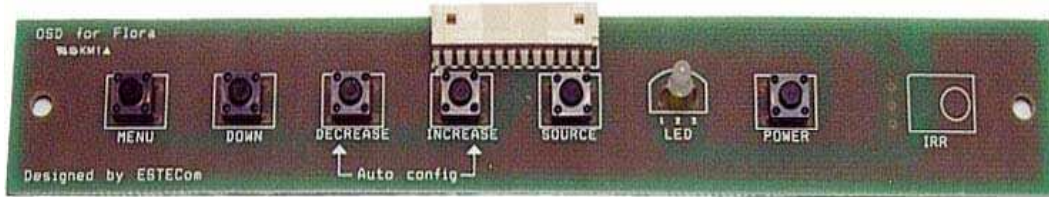

Menu(Enter)/Down(Auto Config.)/Decrease(Left)/Increase(Right)/Source Select(Exit)/Power

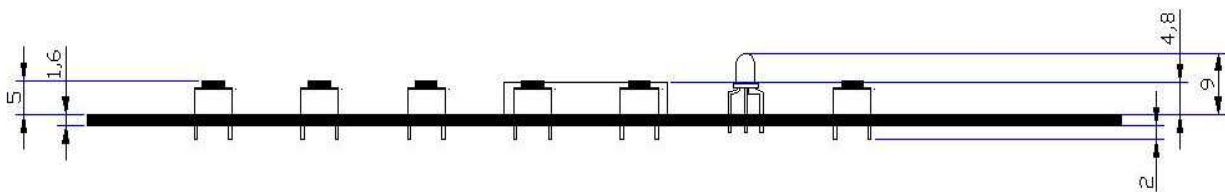
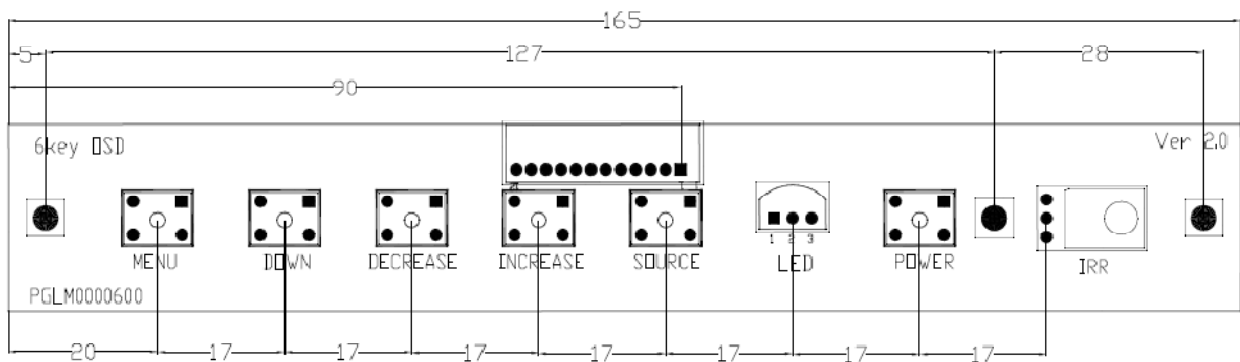

OSD Key Description

- MENU : Menu Key
- DOWN (Auto) : Down Key (HOT Key : Auto Config.)
- DECREASE : Decrease Key, Left Key
- INCREASE : Increase Key, Right Key
- SOURCE/EXIT : Source Select & Exit HOT Key : Source Select [Analog – DVI]

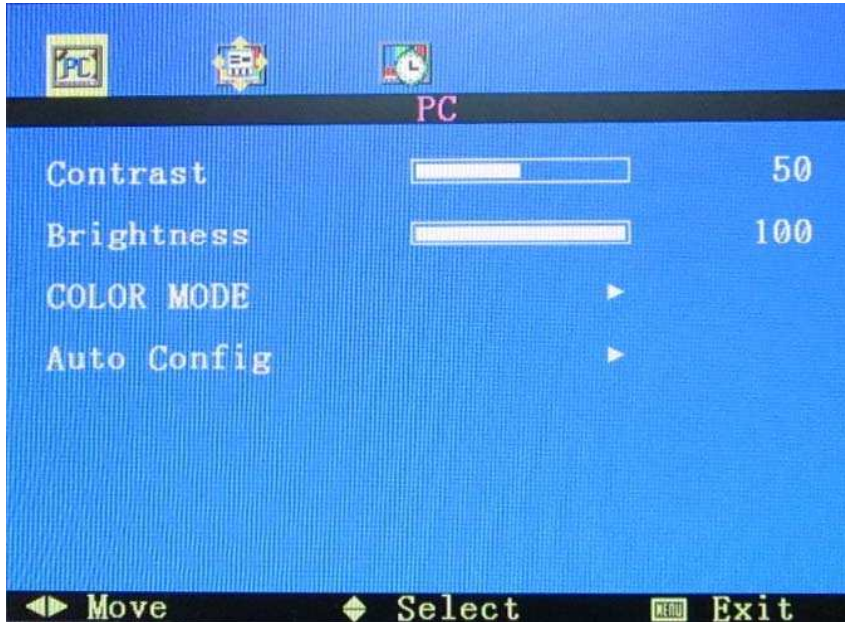

Main Menu	Sub Menu	Operation
PC	contrast	-Contrast is ratio of luminance between black and white. -Adjust distinction.
	Brightness	-Adjust Brightness of the screen.
	COLOR MODE	- Color adjustment, go to sub-menu.
	Auto Config	- Auto configuration of geometry.

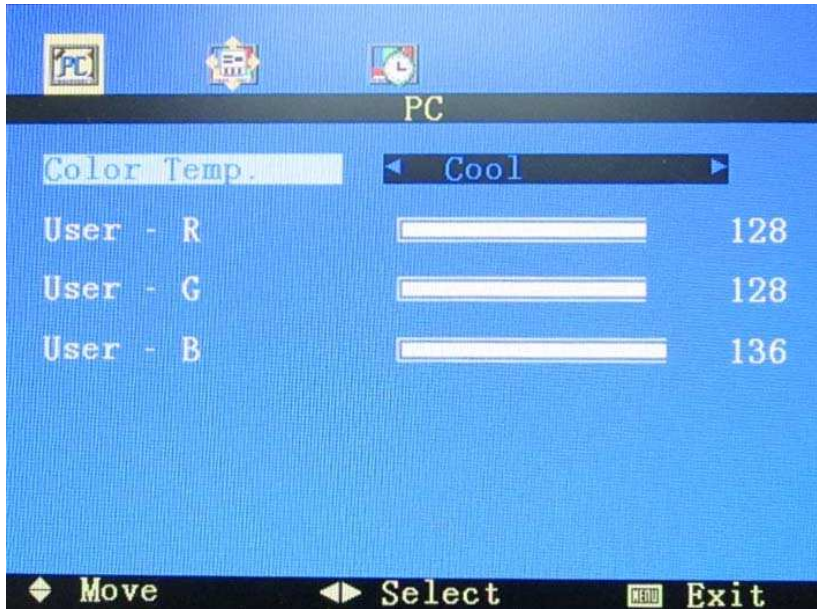

Main Menu	Sub Menu	Operation
COLOR	Temperature	<ul style="list-style-type: none"> -Choice of Warm, Normal, Cool and user's option is chosen, RGB can be adjusted. -User : Able to adjust the color by controlling Red, Green, and Blue. - Warm : Red-tinged screen. - Normal : Green-tinged screen. - Cool : blue-tinged screen.

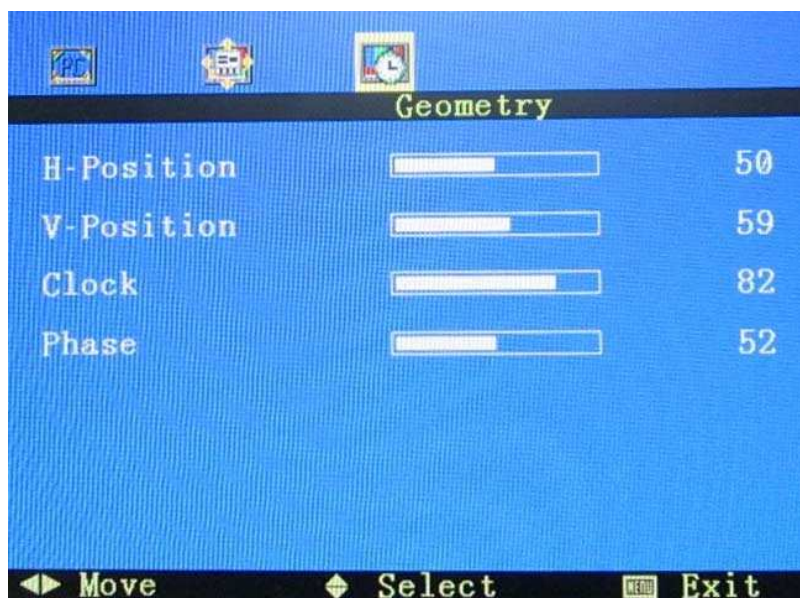

Main Menu	Sub Menu	Operation
Geometry <u>Available Mode</u> - Analog RGB	H Position	- Move screen horizontally.
	V Position	- Move screen vertically.
	Clock	- Adjust horizontal size of the screen by increasing or decreasing the number of picture elements.
	Phase	- Adjust Phase of screen. Used when noise or overlapped lines are shown on the screen.

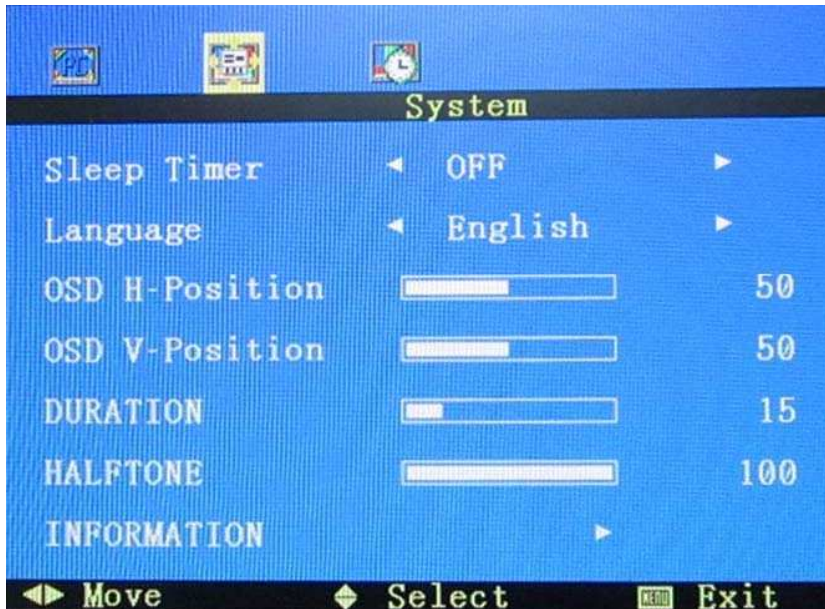

Main Menu	Sub Menu	Operation
System	Sleep Timer	- User can make up OSD showing time.
	Language	- English only available.
	OSD Control	- H Position : Adjust horizontal position of OSD Menu by value. - V Position : Adjust vertical position of OSD Menu by value. - Duration : The range of controlling the duration time of the OSD menu (OSD turn-off time).
	HALFTONE	- User control OSD transparency.
	Information	- Display current input resolution & firmware part number

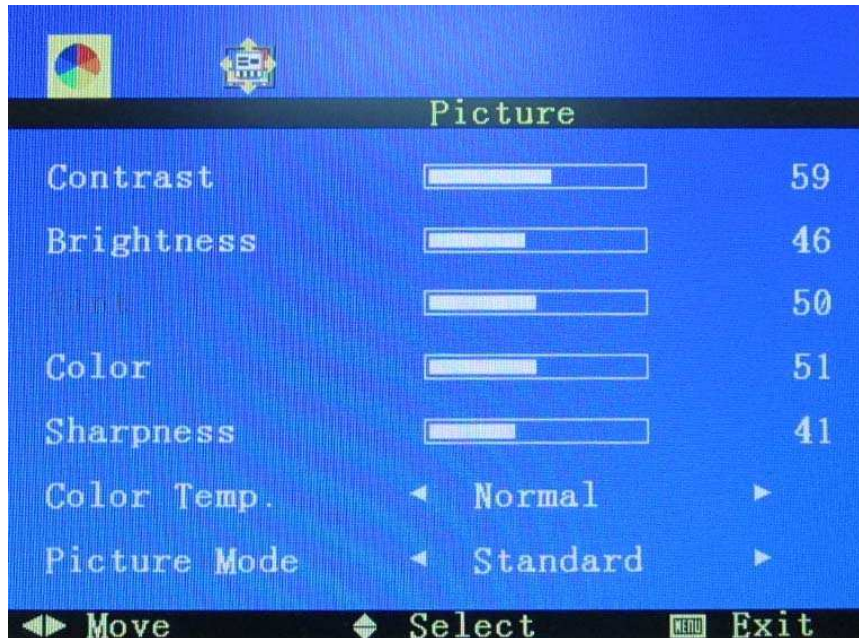

Main Menu	Sub Menu	Operation
Picture <u>Available Mode</u> - Video mode	contrast	-Contrast is ratio of luminance between black and white. -Adjust distinction.
	Brightness	-Adjust Brightness of the screen.
	Tint	- Adjust small amount of color
	Color (Hue)	- Adjust between green tone and purple tone.
	Color temp	- Choice of Warm, Normal, Cool and user's option is chosen, RGB can be adjusted.
	Picture mode	- Choice of Standard, Movie, Vivid And user's option is chosen.