

# 1210 Standard

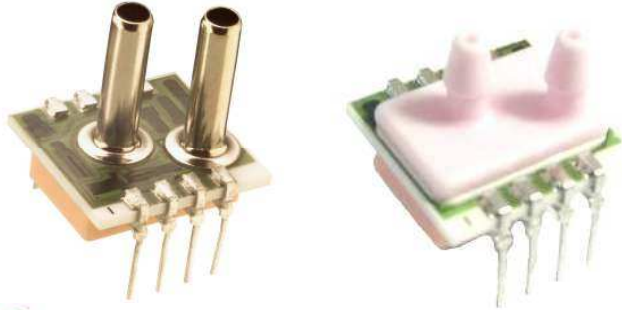

- PC Board Mountable Pressure Sensor
- 0-100 mV Output
- Current Excitation
- Gage, Absolute, and Differential
- Temperature Compensated

## DESCRIPTION

The 1210 is a temperature compensated, piezoresistive silicon pressure sensor packaged in a dual-in-line configuration. It is intended for cost sensitive applications where excellent performance and long-term stability are required.

Integral temperature compensation is provided over a range of 0-50°C using laser-trimmed resistors. An additional laser-trimmed resistor is included to normalize pressure sensitivity variations by programming the gain of an external differential amplifier. This provides sensitivity interchangeability of ±1%. Gage, absolute, and differential pressure ranges from 0-2 psi to 0-100 psi are available. Multiple lead and tube configurations are available for specific applications.

Please refer to the 1210 1 psi datasheet for low pressure applications. For voltage excitation, please refer to the Model 1220.

## FEATURES

- Dual-in-Line Package
- 0°C to 50°C Compensated Temperature Range
- ±0.1% Non Linearity
- 1.0% Interchangeable Span (provided by gain set resistor)
- Solid State Reliability

## APPLICATIONS

- Medical Instruments
- Airspeed and Altitude Measurements
- Process Control
- Factory Automation
- Vacuum Measurement
- Handheld Calibrators

## STANDARD RANGES

Range	psia	psid	psig	Port Styles
0 to 2		•	•	S, L, N, B*
0 to 5	•	•	•	S, L, N, B*
0 to 15	•	•	•	S, L, N
0 to 30	•	•	•	S, L, N,
0 to 50	•	•	•	S, L, N
0 to 100	•	•	•	S, L, N

\*Barb port styles are only available in lead configuration type 3. See Ordering Information.

# 1210 Standard

## PERFORMANCE SPECIFICATIONS

Supply Current: 1.5mA

Ambient Temperature: 25°C (unless otherwise specified)

PARAMETERS	MIN	TYP	MAX	UNITS	NOTES
Span	75	100	150	mV	1
Span (2 psi version)	30		60	mV	1
Zero Pressure Output	-2		2	mV	
Pressure Non Linearity	-0.1	±0.05	0.1	%Span	2
Pressure Hysteresis	-0.05	±0.01	0.05	%Span	
Input & Output Resistance	2500	4400	6000	Ω	
Temperature Error – Span	-0.5	±0.3	0.5	%Span	3
Temperature Error – Zero	-0.5	±0.1	0.5	%Span	3
Thermal Hysteresis – Zero		±0.1		%Span	3
Supply Current		1.5	2.0	mA	
Response Time (10% to 90%)		1.0		mS	4
Output Noise (10Hz to 1kHz)		1.0		μV p-p	
Long Term Stability (Offset & Span)		±0.1		%Span	5
Pressure Overload			3X	Rated	6
Compensated Temperature	0		50	°C	
Operating Temperature	-40		+125	°C	
Storage Temperature	-50		+150	°C	
Weight			3	grams	
Solder Temperature	250°C Max 5 Sec.				
Media	Non-Corrosive Dry Gases Compatible with Silicon, Pyrex, RTV, Gold, Ceramic, Nickel, and Aluminum				

### Notes

1. Ratiometric to supply current.
2. Best fit straight line.
3. Maximum temperature error between 0°C and 50°C with respect to 25°C. For 2psi devices, Temperature Error -- Zero is ±1%.
4. For a zero-to-full scale pressure step change.
5. Long term stability over a one year period with constant current and temperature.
6. 2X maximum for 100psi device. 20psi maximum for 2 and 5psi devices.

# 1210 Standard

## DIMENSIONS

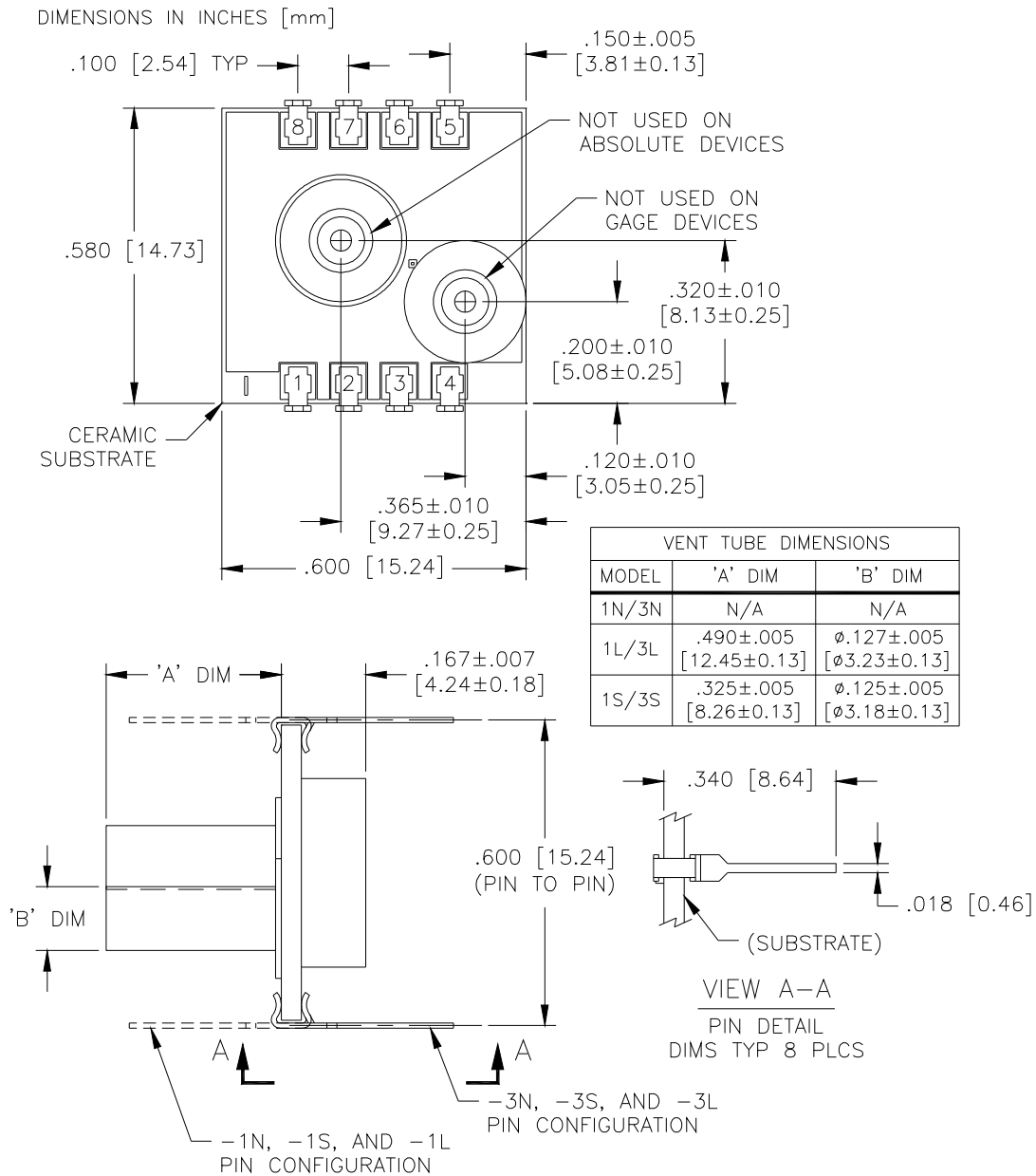

# 1210 Standard

## BARB DIMENSIONS

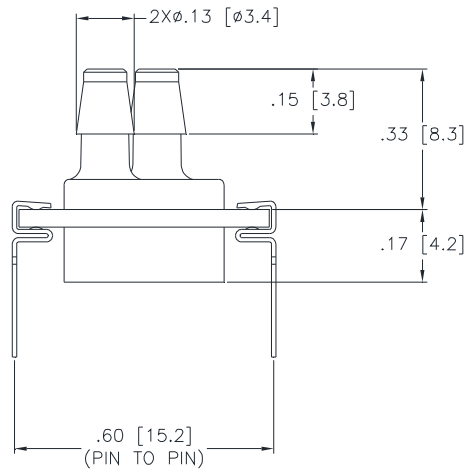
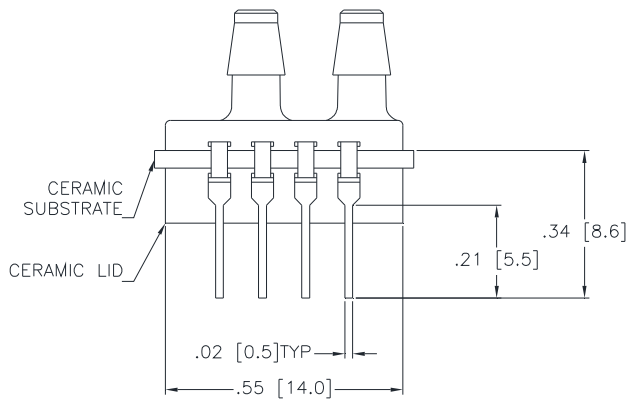
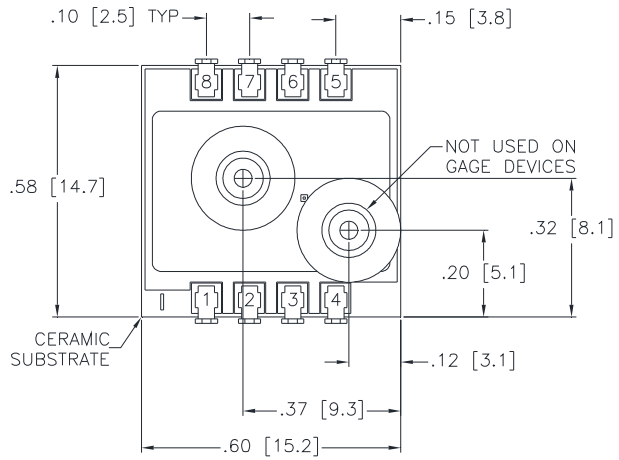

CONNECTIONS

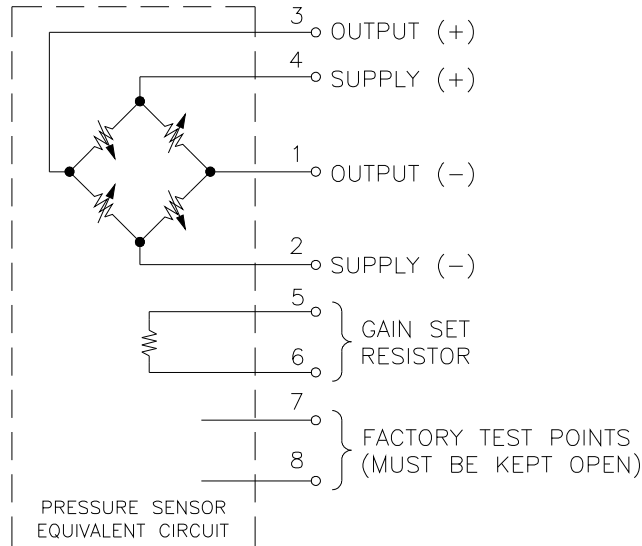

APPLICATION SCHEMATIC

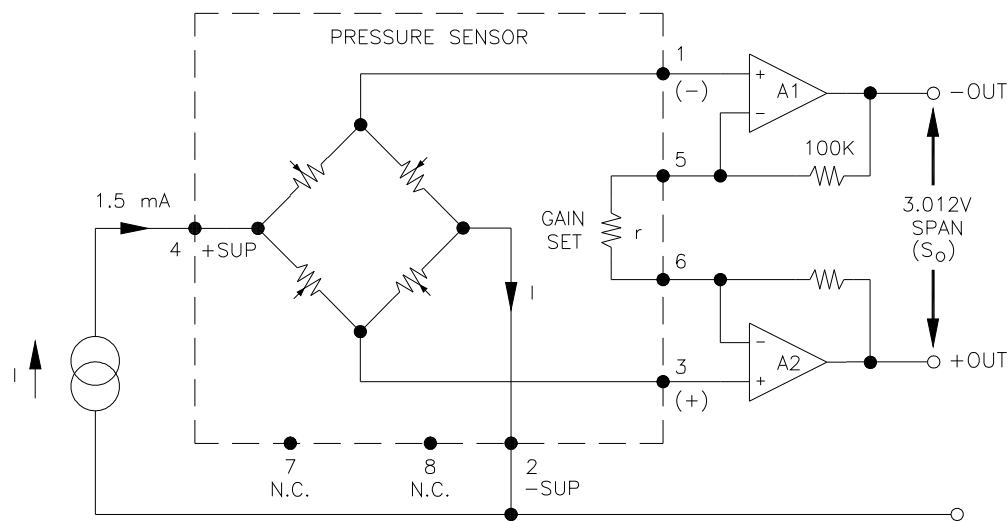

APPLICATION SCHEMATIC

# 1210 Standard

## ORDERING INFORMATION

1210 A - 015 G - 3 S

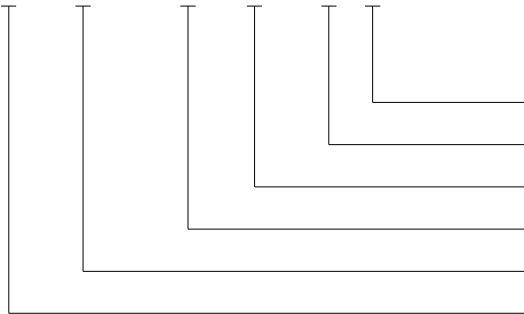

Pressure Tubes (L = Long, S = Short, N = None, B = Barb)

Lead Configuration (1, 3 - See Dimensions Diagram)

Type (G= Gage, A = Absolute, D = Differential)

Pressure Range

Grade

Model

\*Barb port styles are only available in lead configuration type 3.

### NORTH AMERICA

Measurement Specialties  
45738 Northport Loop West  
Fremont, CA 94538  
Tel: 1-800-767-1888  
Fax: 1-510-498-1578  
Sales: [pfg.cs.amer@meas-spec.com](mailto:pfg.cs.amer@meas-spec.com)

### EUROPE

Measurement Specialties  
(Europe), Ltd.  
26 Rue des Dames  
78340 Les Clayes-sous-Bois, France  
Tel: +33 (0) 130 79 33 00  
Fax: +33 (0) 134 81 03 59  
Sales: [pfg.cs.emea@meas-spec.com](mailto:pfg.cs.emea@meas-spec.com)

### ASIA

Measurement Specialties  
(China), Ltd.  
No. 26 Langshan Road  
Shenzhen High-Tech Park (North)  
Nanshan District, Shenzhen 518057  
China  
Tel: +86 755 3330 5088  
Fax: +86 755 3330 5099  
Sales: [pfg.cs.asia@meas-spec.com](mailto:pfg.cs.asia@meas-spec.com)

The information in this sheet has been carefully reviewed and is believed to be accurate; however, no responsibility is assumed for inaccuracies. Furthermore, this information does not convey to the purchaser of such devices any license under the patent rights to the manufacturer. Measurement Specialties, Inc. reserves the right to make changes without further notice to any product herein. Measurement Specialties, Inc. makes no warranty, representation or guarantee regarding the suitability of its product for any particular purpose, nor does Measurement Specialties, Inc. assume any liability arising out of the application or use of any product or circuit and specifically disclaims any and all liability, including without limitation consequential or incidental damages. Typical parameters can and do vary in different applications. All operating parameters must be validated for each customer application by customer's technical experts. Measurement Specialties, Inc. does not convey any license under its patent rights nor the rights of others.